



City of Los Angeles

Department of Recreation and Parks

Request for Proposals

For the Operation and Maintenance of the

GREEK THEATRE FOOD AND BEVERAGE CONCESSION (CON-XXX-XXX)

At

2700 N. Vermont Drive, Griffith Park
Los Angeles, CA 90027



Release Date:

June XX, 2015

Pre-Proposal Conference:

July XX, 2015 (see Exhibit B)

Due Date:

August XX, 2015 (see Exhibit B)

CITY OF LOS ANGELES, DEPARTMENT OF RECREATION AND PARKS
350 S. Grand Ave., 47th Floor
Los Angeles, CA 90071

Telephone: (213) 202-4303

Fax: (213) 202-4311

Web: www.laparks.org/proposal.htm

<http://www.labavn.org/>

email: agnes.ko@lacity.org

TABLE OF CONTENTS
OPERATION AND MAINTENANCE OF GREEK THEATRE
FOOD AND BEVERAGE CONCESSION
REQUEST FOR PROPOSALS

I. Introduction..... 1

II. Objective of the Request for Proposals..... 1

III. Description of the Greek Theatre and the Concession..... 2

IV. Proposal Items 3

V. Evaluation and Award..... 6

A. Evaluation Process and Criteria..... 6

B. Evaluation and Recommendation 7

C. Award..... 7

VI. Exhibits (Listing) 9

A. Premises Map

B. Instructions to Proposers

C. Level I Requirements

D. Compliance Documents

E. Sample Concession Agreement

F. Pro Forma Financial Statements Submittal Forms

G. Insurance Requirements

H. Bidder Contributions – CEC Form 55 (Measure H)

I. First Source Hiring Ordinance

J. Good Food Purchasing Policy (Pledge included)

K. Greek Theatre Venue Data

L. Community Research Overview

**REQUEST FOR PROPOSALS
FOR THE OPERATION AND MAINTENANCE OF GREEK THEATRE
FOOD AND BEVERAGE CONCESSION
REQUEST FOR PROPOSALS**

I. INTRODUCTION

The Department of Recreation and Parks (hereinafter “Department”) is pleased to offer an exciting opportunity for a well-qualified business entity to operate and maintain the Food and Beverage Concession at the Greek Theatre (hereinafter “Concession”).

The proposing individual or company shall demonstrate the experience and ability to perform in the concert venue business, clearly articulate achievable plans for innovative and profitable operation, and be able to document compliance with appropriate laws and regulations.

The selected proposer (hereinafter “Concessionaire”) shall demonstrate the ability to implement a concession program that will meet or exceed the objectives of the City of Los Angeles (hereinafter “City”), as well as incorporate creative ideas that are appropriate to maximize the Concession.

The Department’s goals are to (1) provide the public with the best and highest quality products and service from the Concession, (2) ensure that the City receives adequate and appropriate revenue share from private businesses allowed to operate on park property and (3) protect City assets.

II. OBJECTIVE OF THE REQUEST FOR PROPOSALS

The objective of this Request for Proposals (hereinafter “RFP”) is to award a one (1) year Concession Agreement beginning 2016 (hereinafter “Agreement”), with two (2) one (1) year extension options exercisable at the sole discretion of the Department, along with approval of the Board of Recreation and Parks Commission, to an operator who will accomplish the following:

- Provide Food and Beverage service for a minimum of fifty (50) and as many as seventy (70) show events at the Greek Theatre between April and October.
- Provide food and beverage service on the front plaza area on a year round basis to serve the public visiting Griffith Park/Shuttle Service, while being sensitive to the surrounding community, (the concept of a year round Coffee/Grab & Go is in an early stage to accommodate shuttle service, centered at the Greek Theatre parking lot).
- Provide service to meet the needs and expectations of the City, concert attendees, park patrons and the neighboring community with a possible court yard seating area.
- Minimize wait times for both food and beverage.
- Maximize patron experience through high-quality and uniquely featured menu items, quality of service, and an attractive ambiance.
- Provide professional service at reasonable, market prices.
- Assess, install and provide on-going maintenance and equipment, such as all necessary furnishings and equipment, to create an attractive and inviting Concession.

- Provide food and beverage which incorporates the demographics and needs of the community and patrons this Concession serves.
- Establish and increase a strong customer base at the Concession through the use of marketing and advertising tools and outreach to the community.
- Coordinate with the Department to develop menu items/concessions for the Greek Theatre show season as well as non-concert events ie., corporate events, community, and special events.
- Implement, maintain and enforce all safety rules and regulations related to this Concession.

III. DESCRIPTION OF THE GREEK THEATRE AND THE CONCESSION

The Greek Theatre, located at 2700 N. Vermont Avenue in Griffith Park, is nestled in the picturesque tree-enclosed setting of Griffith Park. This award-winning theatre was built in 1929 and is one of Los Angeles' most historic entertainment venues; it has played host to some of the biggest names in entertainment, from pop to classical and reggae to rock.

The Greek Theatre is part of Griffith Park, which is designated as Historic-Cultural Monument (HCM) No. LA-942 in accordance with Chapter 9, Article 1 of the Los Angeles Administrative Code. HCM LA-942 includes the Greek Theatre as a historically significant contributing element. HCM LA-942 is also listed in the California Register of Historic Resources as eligible for the National Register of Historic Places. Therefore, the Greek Theatre is considered historically significant for California Environmental Quality Act (CEQA) purposes.

This 5,801-seat venue offers an intimate concert setting, with state-of-the-art acoustics combined with excellent sight lines. The Greek Theatre offers top quality entertainment under the stars in the heart of Los Angeles. The Greek Theatre consists of a theatre building and the surrounding hillside: The main theatre structure (all areas, structures and concession facilities in the North Wing, South Wing, North Concourse, South Concourse and Front Concourse; seating areas; light booth; immediate exterior walls; fencing and public access areas fronting North Vermont Avenue, the Box Office structure, and the public restrooms), the VIP Parking Lot, and parking in the adjacent valley west of the theatre.

The Greek Theatre is an important community asset for the citizens of Los Angeles. It has hosted community events such as Bach, Rock and Shakespeare, which is performed annually by John Marshall High School, as well as other music outreach programs. The Greek Theatre has also hosted private, corporate and social events and is a unique venue for hosting a wide variety of private events.

The Greek Theatre is owned by the City of Los Angeles, Department of Recreation and Parks. It has become a world-renowned, award-winning Amphitheatre hosting thousands of events since opening in 1931, making it one of the cultural icons of the City. The Greek Theatre has been named North America's Best Small Outdoor Venue multiple times, and has been ranked in the top twenty-five (25) amphitheaters in the country consistently over the last ten (10) years, from a ticket sales stand point, according to Pollstar magazine, the industry's leading trade publication.

Please review Exhibit I for an overview of data related to the Greek Theatre.

The Concession premises are located within the Greek Theatre venue. The Concessionaire will have rights to use the following areas (described herein in Exhibit "A"):

- North and South Concession Stands
- Front Plaza Area
- Upper and Lower Zeus Bars

Office and storage spaces will be provided in the basement of the Greek Theatre.

During concerts and other licensed events, the Hospitality Room and the adjacent Redwood Decks may be excluded from the food and beverage concession. Events held in the Hospitality Room and the Redwood Deck may be used by the show promoter who may bring in their own caterer. All non-concert events will use the Food and Beverage Concessionaire except for hospitality, Redwood Deck, and backstage.

Promoters will be responsible for backstage catering for the artists' entourage and crew. Unless contracted by the show promoter, the backstage catering dining and kitchen areas are excluded from this food and beverage concession.

The Department shall retain all rights to sponsorships, including non-alcoholic pouring rights, at the Greek Theatre. The successful concessionaire shall collaborate with the Department to secure and receive financial benefits from sponsorship opportunities throughout the venue.

IV. PROPOSAL ITEMS

In the written proposal, proposers should include explicit, detailed responses to each of the Proposal Items. If selected as the winning proposal, the proposer must be willing and able to commit to the Proposal Items and all provisions contained in the Sample Concession Agreement. The contents of a proposer's response will be deemed as a binding commitment and included as an attachment to the Agreement.

Proposers must respond to each of the following items in their written proposal. Each response in the proposal must be numbered to correspond with each of the numbered items herein. Ensure to include a response to all items listed in Section II, Objectives of the Request for Proposals.

Proposal Items

- A. Business Plan
- B. Proposed Operational Plan for Front Plaza Area
- C. Proposed Revenue-Sharing Payment

NOTE: ONLY ONE PLAN FOR EACH PROPOSAL ITEM WILL BE ACCEPTED. MULTIPLE PROPOSAL OPTIONS WILL BE CAUSE TO FIND THE SUBMITTED PROPOSAL NON-RESPONSIVE TO THE RFP.

A. Business Plan- Refer to II. Objective of the Request for Proposals

The selected proposer shall manage the Greek Theatre Food and Beverage Concession and work in conjunction with the contracted oversight management team to deliver high quality food and beverage offerings to concert attendees and park patrons. The proposed Business Plan must address the objectives stated in Section II, Objectives of the Request for Proposals. During the concert season, this Concession will be open a minimum of one and a half (1.5 hours) before the concert and close no later than thirty (30) minutes after the concert. Provide description of key personnel, their experience including licenses and certifications who will be assigned to perform work on site under the Agreement, there must be a minimum of one dedicated person to manage all concert and non-concert events at the Greek Theatre. Note: The On-Site Manager must have a minimum of ten (10) years' experience in food and beverage management. The Food and Beverage management staff will occupy office space on site at the Greek Theatre.

Proposals must include quality food and beverage items, with proposed pricing, including but not limited to, high quality "grab and go" local cuisine, craft beers, wine and non-alcoholic beverages that reflect the cultural diversity of the events and that are designed to comply with the Los Angeles Food Policy Council's Good Food Purchasing Guidelines, Exhibit J. Décor concepts and illustrations for the North and South Concession stands and the temporary/mobile food and beverage areas around the theater must enhance the venue's ambience and create an attractive environment for concert attendees and park patrons and the décor concepts and illustrations for the various areas should be included in the proposal response.

Proposers must provide all concession related equipment, including but not limited to kitchen equipment, mobile food and beverage carts, point of sale systems, credit/debit card machines, and must maintain all equipment in good working condition throughout the term of the Agreement. A list of the major equipment must be included in the proposal response.

All permits and licenses for operating the concession, including but not limited to Health Permits and Alcoholic Beverage Control License, must be maintained throughout the term of the Agreement. The Alcoholic Beverage Control License must be transferrable at fair market value, if applicable.

Proposers must sell artists' merchandise to patrons as part of this Concession. This service does not have any point value and will not be evaluated in the overall scoring. Proposer must state its willingness to provide this service. Proposer expense to provide this service on behalf of the

artists may not exceed 5% of the gross receipts. Artists retain a minimum of 95% of the gross receipts.

A.1 Additional Services and/or Amenities

Proposers are encouraged to consider and propose additional food and beverage business activities and/or amenities (including additional points of sales) at the Concession facility, provided they are appropriate for the Concession, compatible with other Department activities, and approved by the Department. For example, catering during non-concert season, proposer will have first right of refusal or buy out.

A.2 Financial Projections and Planning

Proposers are to complete and submit a Pro Forma Financial Statement submittal form (Submittal Form). A copy of the blank Submittal Form is provided as a reference in Exhibit F. The Submittal Form is a spreadsheet on a CD provided with this RFP, and is also available online by visiting the web page at the following link: <http://www.laparks.org/proposal.htm>. Click on the link to the XXXX Concession RFP; look for the Submittal Form link listed with the Exhibits. Proposers should open and check the file, and report any problems immediately to the Department contact listed on the cover of this RFP.

To complete the Submittal Form, follow the instruction on the first tab of the spreadsheet. Proposers must submit with their proposal both a hardcopy and one (1) new CD-R of the completed Submittal Form.

The Pro Forma Financial Statement submittal form covers anticipated operations over a maximum of a three (3) year term of the Agreement. Projections should demonstrate sound financial planning, be realistic and achievable, and support all elements of the proposal.

The submittal form requires the proposer to enter the following information:

- **Pro Forma Profit and Loss:** Projections for a maximum of a three (3) year term, including projected revenues for each category of sales; variable costs (e.g. cost of goods sold); fixed costs (e.g. salaries, advertising and marketing, revenue-sharing, depreciation, utilities, insurance, etc.); interest and taxes, debt rate, net profit, etc.; proposers will be able to enter any additional information pertinent to your financial planning.
- **Break-Even Analysis:** The proposer's return on investment is reflected here. Proposers should provide narrative explanations of their projected financial planning, indicating any assumptions made in financial planning; for example, expected interest rates, inflation rates, and anticipated increases or decreases in staffing levels; anticipated revenue and/or attendance increases; and if so, by how much. Indicate any research you have undertaken to support your assumptions.

B. Proposed Operational Plan for Front Plaza Area

B.1 Operational Plan for Front Plaza Area during the Concert Season

A plan dictating layout of temporary and or mobile food and beverage areas in and around the front entry plaza with descriptions of quality food and beverage items including but not limited to high quality “grab and go” local cuisine, craft beers, wine and non-alcoholic beverages during the concert season between April and October.

Proposer will provide Greek Theatre merchandise for sale and Department shall retain full ownership of the Greek Theatre logo and design. Net sales of all Greek Theatre merchandise will be 60% to Department and 40% to proposer.

B.2 Operational Plan for Front Plaza Area during the Non-Concert Season

The plan should also include non-concert operation of a year round food and beverage operation in the front plaza area only. During the non-concert season, the front plaza will be open for park patrons. If the food and beverage offerings are different during the non-concert period, include the proposed menu items, along with proposed pricing.

Proposer will provide Greek Theatre merchandise for sale and Department shall retain full ownership of the Greek Theatre logo and design. Net sales of all Greek Theatre merchandise will be 60% to Department and 40% to proposer.

C. Proposed Revenue-Sharing Payment

A revenue-sharing fee is paid monthly by the Concessionaire to the Department, to be proposed as follows:

NOTE: ONLY ONE REVENUE-SHARING PAYMENT PROPOSAL PER SUBMITTAL. MULTIPLE REVENUE-SHARING PAYMENT PROPOSALS WILL BE CAUSE TO FIND THE SUBMITTED PROPOSAL NON-RESPONSIVE TO THE RFP.

Revenue-Sharing Terms: The Minimum Acceptable percentage for this RFP is forty percent (40%) of gross receipts for all food and beverage sold annually. The annual minimum revenue-sharing payment for this Concession per calendar year will be determined by the percentage of gross receipts or One Million Three Hundred Thousand Dollars (\$1,300,000), whichever is greater. If the annual minimum revenue-sharing payment is not met by December 31st of each calendar year, the difference between the actual revenue-sharing payment received by the Department and the annual minimum revenue-sharing payment will be due to the Department by January 15th for the preceding year, pro-rated as necessary for the first year of operation or fractional part thereof, and pro-rated as necessary for the final year of operation or fractional part thereof. Refer to the Sample Concession Agreement (Exhibit E).

C.1 ___ Revenue-sharing payment must be stated as a Percentage of Gross Receipts. Refer to Exhibit E, Section 6.C, for the definition of Gross Receipts.

C.2 ___ Revenue-sharing terms must also be indicated in the Pro Forma Financial Statement submittal form.

C.3 ___ Proposer must provide justification, based on their financial projections, planning, and relevant market research, that the proposed revenue-sharing payment is competitive as well as sustainable and realistic.

V. EVALUATION AND AWARD

A. Evaluation Process and Criteria

The Department reserves the right to request additional information to clarify a submitted proposal. The evaluation of proposals will consist of two levels. **Each proposer must pass Level I in order to advance to Level II.**

Tentative Interview Dates:

Interviews of the proposers by the evaluation panel will be scheduled at a later date for the purpose of clarifying matters in the proposals or responding to questions by the evaluation panel.

Level I – Compliance with RFP Submission Requirements: (Exhibits B, C and D)

The Department will conduct a preliminary evaluation of all proposals submitted by the deadline to determine compliance with proposal requirements and mandatory document submissions.

- Cover Letter. Refer to Exhibit B.
- Proposal Deposit (\$20,000.00)
- Compliance Documents. Refer to Exhibit D.
- Background and Experience. Refer to Exhibit C.
- Financial Capacity. Refer to Exhibit C.

Provide a current list of Food and Beverage Venue operations contracts with contact names and references for each venue under your managerial control.

Level II – Evaluation and Scoring Criteria of Proposal Items:

For the purposes of Level II evaluation, the responsive proposals will be evaluated, ranked and scored based on the criteria below:

Business Plan (25 points possible)

Front Plaza Operational Plan During the Concert Season (10 points possible)

Front Plaza Operational Plan During the Non-Concert Season (5 points possible)

Proposed Revenue-sharing Payment (60 points possible)

B. Evaluation and Recommendation

Responsive proposals will be scored in each of the criteria above and ranked according to scores. A comprehensive evaluation of the proposals by a panel of City and/or non-City employees will be conducted.

Furthermore, the City reserves the right to conduct such investigations as the City considers appropriate with respect to the qualifications of each Respondent and any information contained in its proposal.

All proposals will be evaluated solely on the basis of the criteria listed above and the ranking of any outside expert review panel will serve as a basis to formulate the General Manager's recommendation, setting forth the reasons for recommendation in a Board Report. The Board of Recreation and Park Commissioners (Board) will consider the General Manager's recommendation during a public Board meeting and may accept or reject the General Manager's recommendation in making its decision as to the selection, if any, stating publicly the reasons for their action.

C. Award

The General Manager of the Department of Recreation and Parks recommends contract awards to the Board of Recreation and Park Commissioners. The Department shall notify all proposers in writing of the General Manager's recommendation.

Section 10.5 of the Los Angeles Administrative Code requires approval by the City Council of contracts for periods of longer than three (3) years. Agreements are deemed to be executed upon the date of signature, or as otherwise stipulated under the Terms section of the Agreement.

Once the award is approved, the awarded concessionaire will complete and submit the additional documents as required by this RFP, City Attorney, City Ordinance, State and/or Federal laws within forty-five (45) calendar days from the date the contract is awarded by the Board.

IMPORTANT:

Charter Section 371(e)(10)

In approving this RFP, the Board, in its capacity as the contract awarding authority for the Department, finds, pursuant to Charter Section 371(e)(10), that the use of competitive bidding would be undesirable, impractical or otherwise excused by the common law and the Charter because, unlike the purchase of a specified product, there is no single criterion, such as price comparison, that will determine which proposer can best provide the services required by the Department for the improvement, operation and maintenance of the Department's concession. To select the best proposer for this concession, the Board finds it is necessary to utilize a standard request for proposals process and to evaluate proposals received based upon the criteria included in this RFP. The Board specifically finds that the narrower and more specialized competitive sealed proposal process authorized but not required by Charter Section 371, subsection (b), would not meet the Department's needs and therefore opts to utilize the standard request for proposals process.

G. City's Right to Reject Proposals and to Waive Informalities

Notwithstanding any other provisions of this RFP, the City reserves the right to withdraw this RFP at any time without prior notice. The City also reserves the right to reject any and all proposals submitted or to waive any minor administrative irregularities contained in any proposal, when to do so would be in the best interest of the City and pursuant to Los Angeles City Charter Section 371 (c): "The City shall reserve the right to reject any and all bids or proposal and to waive any informality in the bid or proposal when to do so would be to the advantage of the City."

VI. EXHIBITS

- A. Premises Map
- B. Instructions to Proposers
- C. Level I Requirements
- D. Compliance Documents
- E. Sample Concession Agreement
- F. Pro Forma Financial Statements Submittal Forms
- G. Insurance Requirements
- H. Bidder Contributions – CEC Form 55 (Measure H)
- I. First Source Hiring Ordinance
- J. Good Food Purchasing Policy (Pledge included)
- K. Greek Theatre Venue Data
- L. Community Research Overview

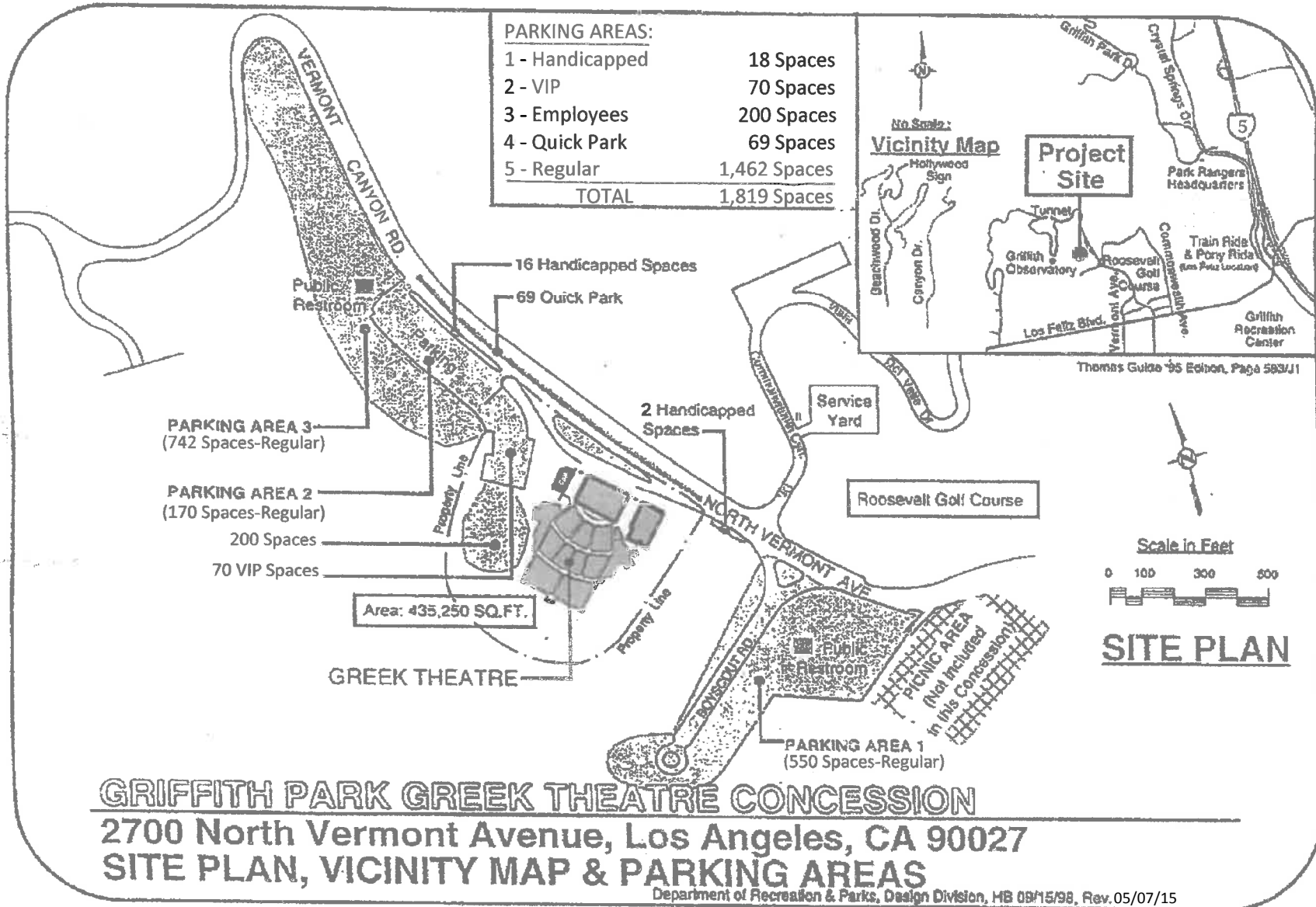

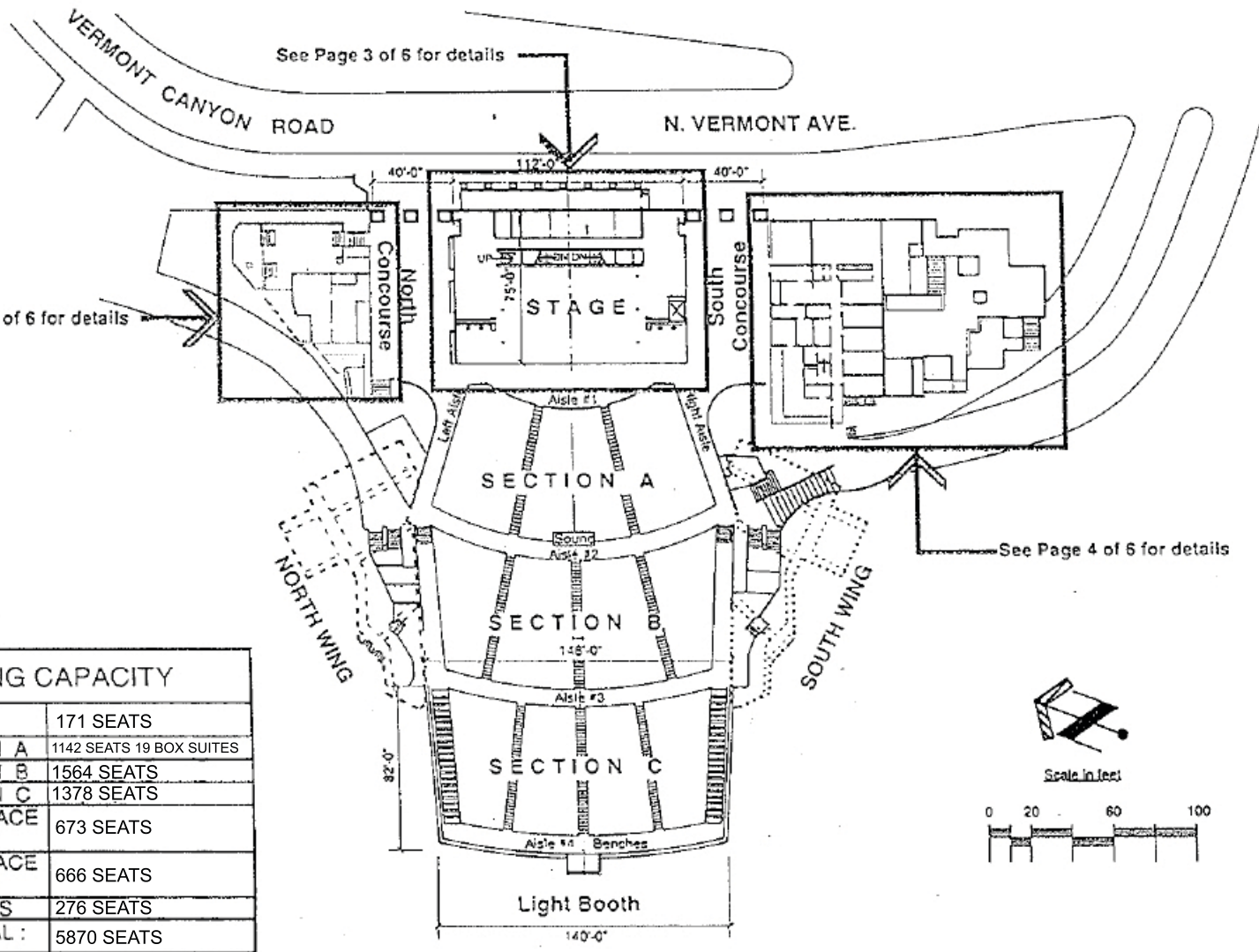

SEATING CAPACITY	
PIT	171 SEATS
SECTION A	1142 SEATS 19 BOX SUITES
SECTION B	1564 SEATS
SECTION C	1378 SEATS
N. TERRACE (N. Wing)	673 SEATS
S. TERRACE (S. Wing)	666 SEATS
BENCHES	276 SEATS
TOTAL :	5870 SEATS

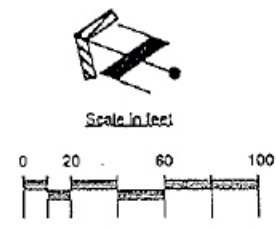

GRIFFITH PARK GREEK THEATRE CONCESSION
 2700 North Vermont Avenue, Los Angeles, CA 90027
FIRST FLOOR PLAN

North
Concourse

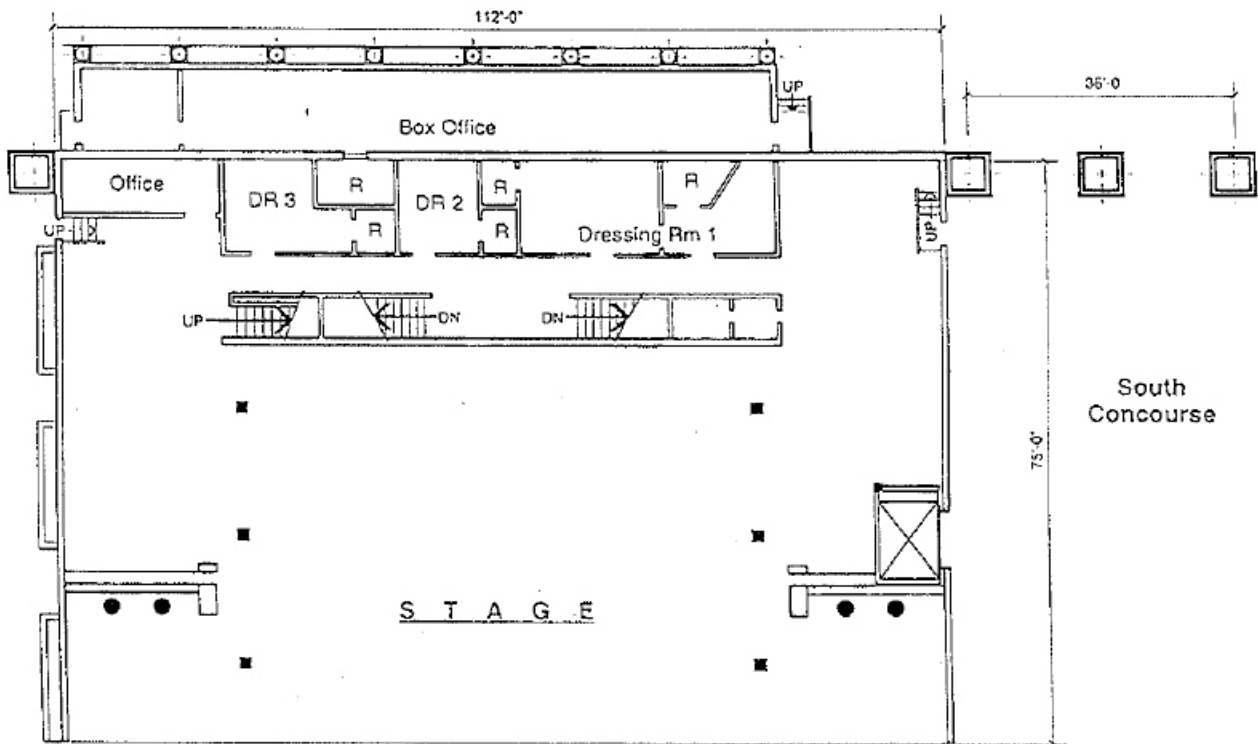

South
Concourse

S T A G E

FIRST FLOOR

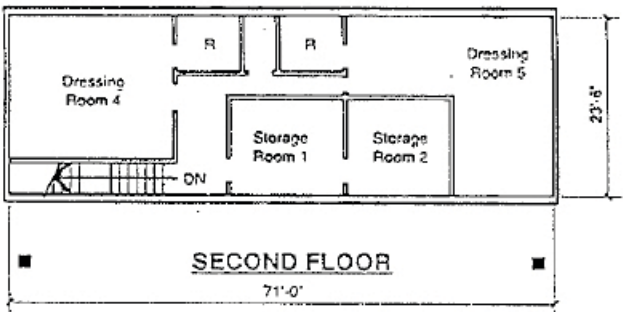

SECOND FLOOR

Scale in Feet

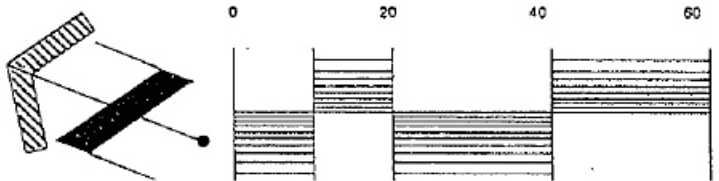

GRIFFITH PARK GREEK THEATRE CONCESSION
 2700 North Vermont Avenue, Los Angeles, CA 90027
FIRST FLOOR (STAGE) AND SECOND FLOOR

**SOUTH
CONCOURSE**

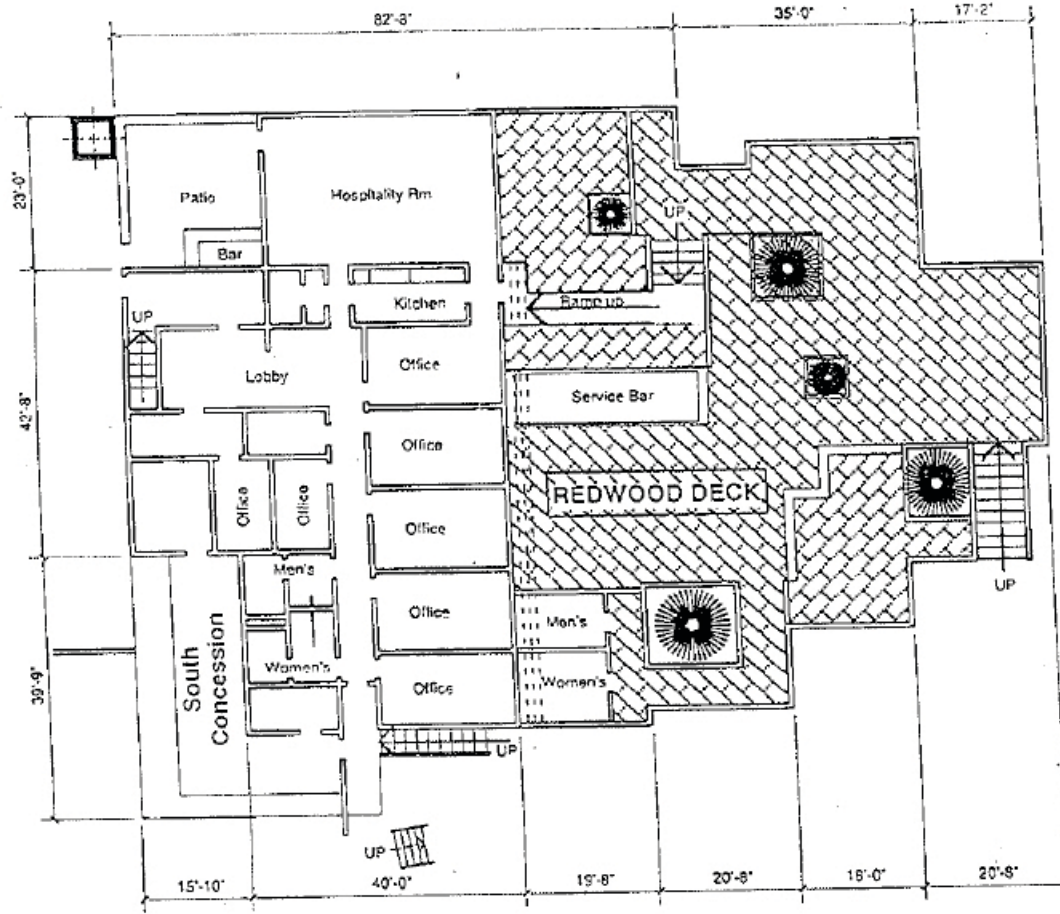

Scale in Feet

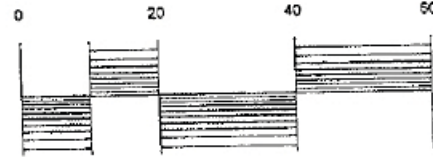
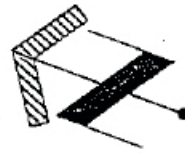

GRIFFITH PARK GREEK THEATRE CONCESSION
 2700 North Vermont Avenue, Los Angeles, CA 90027
FIRST FLOOR / SOUTH WING

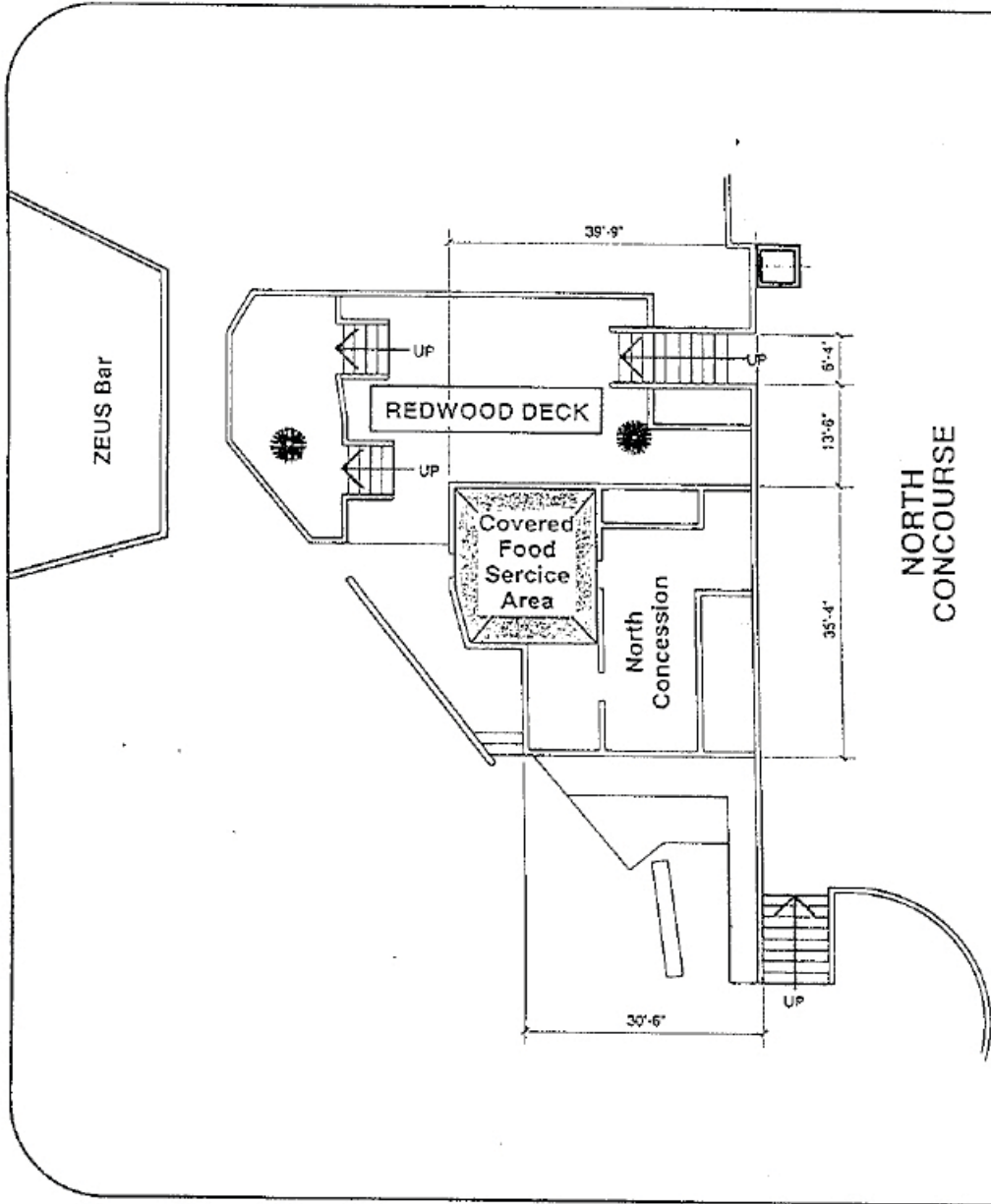

**NORTH
CONCOURSE**

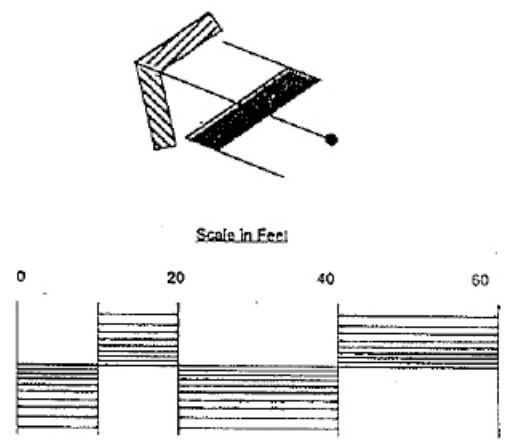

GRIFFITH PARK GREEK THEATRE CONCESSION
 2700 North Vermont Avenue, Los Angeles, CA 90027
FIRST FLOOR / NORTH WING

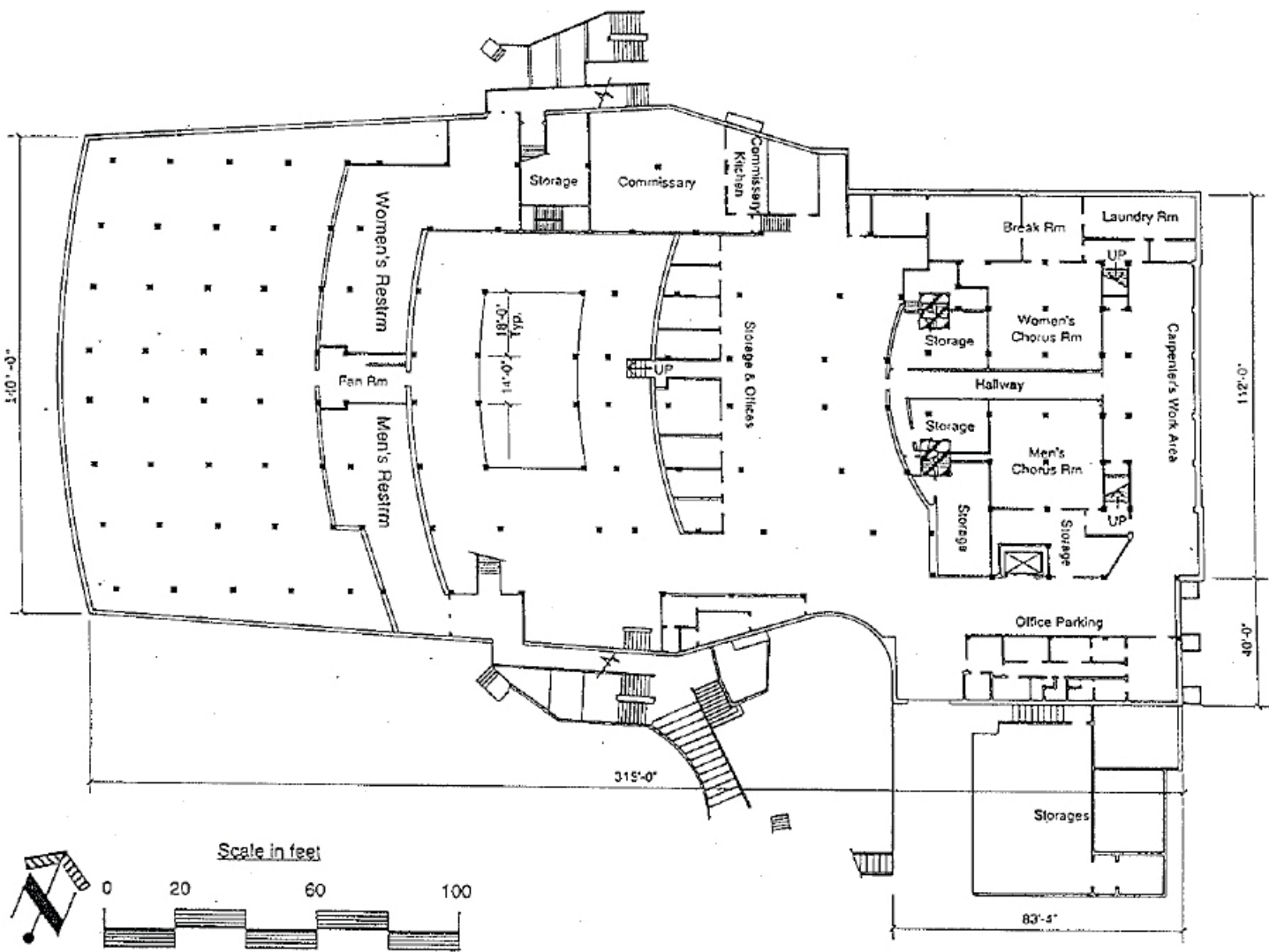

GRIFFITH PARK GREEK THEATRE CONCESSION
2700 North Vermont Avenue, Los Angeles, CA 90027
BASEMENT PLAN

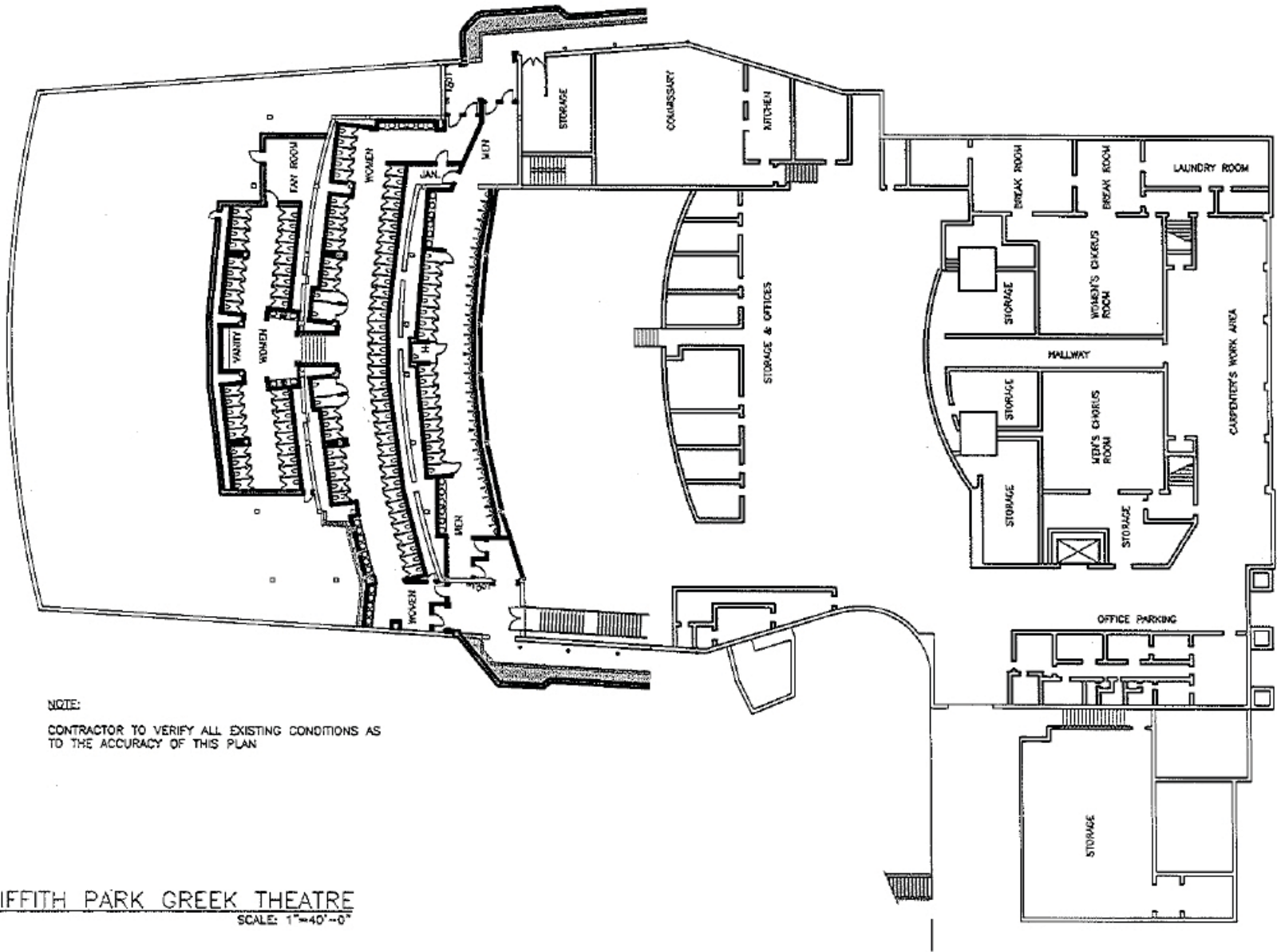

NOTE:

CONTRACTOR TO VERIFY ALL EXISTING CONDITIONS AS TO THE ACCURACY OF THIS PLAN

GRIFFITH PARK GREEK THEATRE
SCALE: 1"=40'-0"

PROJECT NO.	SHEET TITLE NEW RESTROOM FLOORPLAN	GENERAL MANAGER	DESIGN/DATE	DELTA	REVISIONS	BY	DATE	
FILE NO.	PROJECT GRIFFITH PARK GREEK THEATRE CONCESSION	DIRECTOR OF PLANNING & CONSTRUCTION	DRAWN/DATE				05/20/14	
SHEET NO.	FACILITY ADDRESS 2700 NORTH VERMONT AVE. L.A., CA 90027	CONTRACT ADMINISTRATOR	CHECK/DATE					

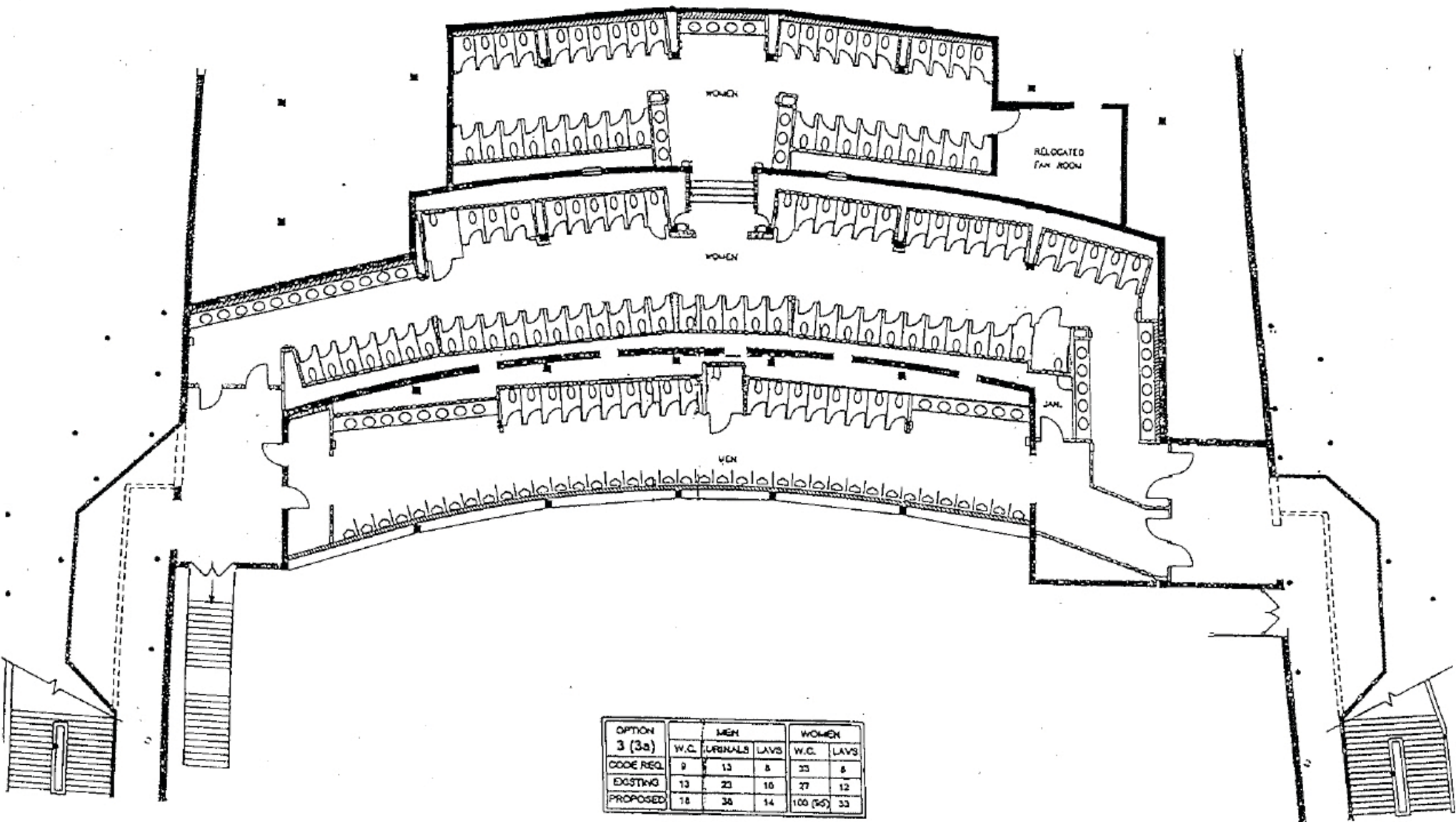

OPTION 3 (3a)	MEN			WOMEN	
	W.C.	URINALS	LAVS	W.C.	LAVS
CODE REQ.	9	13	8	23	8
EXISTING	13	23	10	27	12
PROPOSED	18	38	14	100 (50)	33

GRIFFITH PARK GREEK THEATRE CONCESSION
 2700 North Vermont Avenue, Los Angeles, CA 90027
MEN'S & WOMEN'S RESTROOMS

Rev 05/20/14

**REQUEST FOR PROPOSALS
FOR THE OPERATION AND MAINTENANCE OF THE
GREEK THEATRE FOOD AND BEVERAGE CONCESSION
(CON-XXX-XXX)**

INSTRUCTIONS TO PROPOSERS

A. Submitting a Written Proposal

To be considered for award of this Agreement, proposing entities must submit a sealed, written proposal in response to the Proposal Items indicated herein. Proposals provide information about background, current business practice, applicable experience, and plans for this Concession. Proposals are evaluated based on several evaluation criteria as indicated in this RFP.

Proposers may wish to consider the following guidelines in preparing their proposals:

- Make sure your proposal is well-organized in its response to the Department objectives and easy to read.
- Verify that your proposal is complete and that you have thoroughly responded to all proposal items and compliance documents in the RFP.
- Formulate your responses precisely and with detail; avoid vague, meaningless, or open-ended responses. Explain how your responses further the stated objectives.
- Make sure your proposal demonstrates that your financial projections and cost estimates are realistic and sustainable.
- Clearly describe what your management team will bring to the Greek Theatre.
- If there are significant risks in your business strategy, include plans to mitigate those risks, addressing any contingencies that may arise.

Your written submittal in this RFP process will be the primary basis on which the City will consider its award for the Agreement; therefore, proposers should be as thorough and as detailed as possible when responding to each proposal item and assembling a proposal. In the written proposal, proposers must include responses to ALL proposal items requested herein below. Proposers will not be able to add to or modify their proposals after the proposal due date.

The Department may deem a proposer non-responsive if the proposer fails to provide all required documentation and copies.

B. Submitted Proposals

Proposals accepted by the Department in writing constitute a legally binding contract offer. It is requested that proposals be prepared simply and economically, avoiding the use of unnecessary promotional material. **Submitted Proposals - Proposals must contain ALL of the following:**

1. Cover Letter

Proposers are to include a cover letter indicating the contact information for the entity proposing. Include at a minimum:

Exhibit B to the Greek Theatre Food and Beverage Concession RFP – Draft as of May 12, 2015

**REQUEST FOR PROPOSALS
FOR THE OPERATION AND MAINTENANCE OF THE
GREEK THEATRE FOOD AND BEVERAGE CONCESSION
(CON-XXX-XXX)**

- Proposing company's legal name (to be used on all documentation associated with this RFP and the resultant agreement);
- Type of business (corporation, partnership, or sole proprietorship);
- Key names, including title and position;
- Name of main point of contact; said point of contact will be the only recipient of all information related to this RFP and will function as the equivalent to the Department's Contract Coordinator;
- Complete mailing addresses;
- Telephone and fax numbers (including office and cell numbers as appropriate);
- E-mail addresses, and any other information needed by City staff to contact proposers;
- A statement that the proposing entity confirms its acknowledgement and acceptance of the terms and conditions set forth herein, without exceptions.

2. Proposal Deposit

All proposals must include a Twenty Thousand Dollars (\$20,000.00) Proposal Deposit in the form of a cashier's check only, payable to the **City of Los Angeles**. This amount shall be payable as a guarantee that the selected proposer will enter into an Agreement for the Concession. The selected proposer shall have forty-five (45) calendar days from the date the contract is awarded by the Board to review, sign and return the contract to the Department. In the event the selected proposer fails to return the signed contract and all other required documents within the allotted time frame, a penalty of One Hundred Dollars (\$100.00) per calendar day shall be applied and deducted from the Proposal Deposit. If, after ninety (90) calendar days from the date the contract is awarded, the contract is not signed and returned, the City maintains the right to move on to the proposer with the next highest selection ranking.

The Proposal Deposit of the successful proposer will be released upon receipt of the required Performance Deposit, evidence of insurance and execution of the Agreement. In the event that an award is made and the successful proposer fails to execute the Agreement and to provide the required Performance Deposit and insurance policies, the Proposal Deposit of that proposer will be forfeited and retained by the Department.

The Proposal Deposits of unsuccessful proposers will be returned upon execution of an Agreement with the proposer awarded the Concession. Proposal Deposits are maintained for all proposers in the event the successful proposer fails to execute the Agreement and another proposer is considered for award.

C. Proposal Submitted Information

Deadline for Submission

To be considered, proposals must be received on or before 3:00 pm, XXXX.

**REQUEST FOR PROPOSALS
FOR THE OPERATION AND MAINTENANCE OF THE
GREEK THEATRE FOOD AND BEVERAGE CONCESSION
(CON-XXX-XXX)**

Where to Submit your Proposal

The complete proposal package shall be placed in a sealed envelope(s) or box(es) labeled "Proposal for the Greek Theatre Food and Beverage Concession." Said envelope or box shall have the name and address of the Proposer on the outside and be delivered to:

Los Angeles Department of Recreation and Parks
Office of the Board of Commissioners
Attention: Board Secretary
Two California Plaza
350 S. Grand Ave., 46th Floor
Los Angeles, CA 90071

Number of Copies

Please provide one (1) original, one (1) non-bound reproducible copy, four (4) copies, and an electronic copy on CD, DVD, USB or Flash Drive. Plainly identify the respective documents. An original is one in which a form requiring a signature must be signed in wet ink. A reproducible copy is one which can readily be reproduced through a photocopier. If the proposal contains confidential information, a pre-redacted, non-bound reproducible copy must be provided.

Important Notices

Candidates who mail their proposals should allow adequate mail delivery time to ensure timely receipt of the proposals. Late proposals will not be considered for review. The City reserves the right to determine the timeliness of all proposals submitted. At the day and time appointed, all timely submitted proposals will be opened and the name of the proposer(s) announced. No other information about the proposals will be made public until such time as a recommendation concerning proposals is made to the Board of Recreation and Park Commissioners (Board).

The Department reserves the right to extend the deadline for submission should such action be in the best interest of the City. In the event the deadline is extended, proposers will have the right to revise their proposal. Proposals may be withdrawn personally, by written request, prior to the scheduled closing time for receipt of proposals. Faxed withdrawals will be accepted by the Board Office at (213) 202-2610, Attn: Board Secretary. After withdrawing a previously submitted proposal, the proposer may submit another proposal at any time up to the specified due date and time.

A proposal will be returned only if the above-described withdrawal request explicitly requests that it be returned. It will be returned either to a representative of the proposer who personally presents the withdrawal request with original signature to the Board Office or by USPS mail after the original signed request is received. The proposal will be sent by means of some other service only if the proposer pays for that service.

Submission of a proposal pursuant to this RFP shall constitute acknowledgement and acceptance of the terms and conditions set forth herein. All or portions of this RFP and the contents of the proposal submitted by the successful proposer may become contractual obligations if an Agreement is awarded. Failure of the successful proposer to accept these obligations may result in cancellation

**REQUEST FOR PROPOSALS
FOR THE OPERATION AND MAINTENANCE OF THE
GREEK THEATRE FOOD AND BEVERAGE CONCESSION
(CON-XXX-XXX)**

of the award and forfeiture of the Proposal Deposit. The City reserves the right to withdraw this RFP at any time without prior notice and return proposals and deposits.

All proposals submitted in response to this RFP become the property of the City of Los Angeles, Department of Recreation and Parks.

Mandatory Pre-Proposal Conference and Site Walk

Pre-Proposal Conference (Conference):

Date: XXXX, 2015
Time: 10:00 a.m.- 12:00 p.m.
Location: 2700 N. Vermont Ave., Los Angeles, CA 90027

Site Walk:

Date: XXXX, 2015
Time: 1:00 p.m.
Location: 2700 N. Vermont Ave., Los Angeles, CA 90027

The purpose of the Conference is to clarify the contents of this RFP and to discuss the needs of the Concession. Attendance is mandatory. A site walk of the facility will take place after the conclusion of the conference. Due to the size and complexity of the Concession, additional site walks may be necessary and will be available upon request. **It is highly recommended that prospective proposers read the complete RFP prior to the Conference and begin preparation of their proposal in order to maximize the benefits of the Conference.**

Contact With City Personnel

Please direct all comments and questions to the Contract Coordinator. All contact regarding this RFP or any matter relating thereto must be in writing and may be mailed, e-mailed, or faxed as follows:

Name: Agnes Ko, Contract Coordinator, Concessions Unit
Address: P.O. Box 86610
Los Angeles, CA 90086-0610
E-mail: agnes.ko@lacity.org, Contract Coordinator
Fax: (213) 202-4311

To maximize the effectiveness of the Conference, the Contract Coordinator requests that, to the extent possible, proposers provide questions in writing prior to the Conference. This will enable the Contract Coordinator to prepare responses in advance. Specific questions concerning the RFP should be submitted in writing to the Contract Coordinator.

Additional questions may be accepted, in writing, at the Conference. However, responses may be deferred and provided as addenda to the RFP at a later date. **All questions must be in writing. Responses to questions will be posted to the Department's website and to labavn.org. It is recommended that questions be submitted as soon as possible in order to provide the**

**REQUEST FOR PROPOSALS
FOR THE OPERATION AND MAINTENANCE OF THE
GREEK THEATRE FOOD AND BEVERAGE CONCESSION
(CON-XXX-XXX)**

Department sufficient time to post written responses prior to the deadline to submit a proposal. Questions will be deemed late and may not be answered after XXXX, 2015 5:00 p.m.

All questions, without identifying the submitting company, will be compiled with the appropriate answers and issued as an addendum to the RFP.

When submitting questions, please specify the RFP section number, paragraph number, and page number, and quote the passage that prompted the question. This will ensure that the passage can be quickly found in the RFP. The Department reserves the right to group similar questions when providing answers.

If the Department requirements or the specifications prevent proposers from submitting a proposal that would be beneficial to the City, please address the concern to the Contract Coordinator listed below.

Questions may address concerns that the application of minimum requirements, evaluation criteria and/or business requirements would unfairly disadvantage proposers or, due to unclear instructions, may result in the Department not receiving the best possible responses from proposers.

D. Document Check

Please check the contents of your RFP package carefully to ensure that you have in your possession all the necessary documents as referenced within the RFP, including any addenda. If you are missing any items, you should make a written request to the Contract Coordinator identified above.

The complete RFP package and all forms and information in Exhibits B, F and G are also available at www.laparks.org/proposal.htm. Should you find a discrepancy in or omissions from said documents, or have questions as to their meaning, notify the Contract Coordinator at the above address in writing or fax no later than the deadline date for receiving proposals. The City of Los Angeles will not be bound by any oral statements or representations.

E. Contractual Arrangements

The proposer selected to perform the services outlined in this RFP will enter into an Agreement, approved as to form by the City Attorney, directly with the City of Los Angeles.

F. Verification of Information

The Department reserves the right to verify the information received in the proposal. If a proposer knowingly and willfully submits false information or data, the Department reserves the right to reject that proposal. If it is determined that an Agreement was awarded as a result of false statements or other data submitted in response to this RFP, the Department reserves the right to terminate the Agreement.

**REQUEST FOR PROPOSALS
FOR THE OPERATION AND MAINTENANCE OF THE
GREEK THEATRE FOOD AND BEVERAGE CONCESSION
(CON-XXX-XXX)**

G. Cost of Preparation

All costs of proposal preparation shall be borne by the proposer. The City shall not, in any event, be liable for any expenses incurred by the proposer in the preparation and/or submission of the proposal. All proposers who respond to solicitations do so solely at their own expense.

DRAFT

**REQUEST FOR PROPOSALS
FOR THE OPERATION AND MAINTENANCE OF THE
GREEK THEATRE FOOD AND BEVERAGE CONCESSION
(CON-XXX-XXX)**

LEVEL I REQUIREMENTS

1. Compliance Documents

As part of the RFP process, all proposers are to review, complete, and submit the following compliance documents. Information, related forms, and instructions are located in Exhibits D, H and I of the RFP (“Compliance Documents”).

Previous compliance document submittals and/or waivers do not apply. New forms must be completed and processed.

Additional information regarding some compliance documents may be available at the Pre-Proposal Conference, on a City website, and/or by phone with the administering City Department of a given ordinance or compliance document. Exemptions from certain ordinances may also apply. The Department reserves the right to request additional information and/or clarification regarding submitted compliance documents during the evaluation process.

The following compliance documents MUST be included with your proposal:

- a. Proposer’s Signature Declaration and Affidavit (Section I.A of Exhibit D)
The document must be signed and notarized. Legal name(s) on all proposal documents and the resultant Concession Agreement must be consistent. Only the original notarized form is acceptable.
- b. Disposition of Proposals (Section I.B of Exhibit D)
The document must be signed by an individual authorized to bind the proposer.
- c. Affirmative Action Plan (Section I.C of Exhibit D)
Please read instructions in Exhibit D.
- d. Contractor Responsibility Ordinance Statement (Section I.D of Exhibit D)
Pages 1 through 6 of the document must be completed and submitted with the proposal. Pages 1 and 6 must be signed by an individual authorized to bind the proposer.
- e. Equal Benefits Ordinance Statement (Section I.E of Exhibit D)
Please read the instructions in Exhibit D.
- f. Living Wage Ordinance (LWO)/Service Contractor Worker Retention Ordinance (SCWRO) – *only if applying for an exemption* (Section I.F of Exhibit D). Submittal of documents only required if the proposer is applying for an exemption to the ordinance requirements.
- g. Business Inclusion Program (BIP) Requirements (Section I.G of Exhibit D)

**REQUEST FOR PROPOSALS
FOR THE OPERATION AND MAINTENANCE OF THE
GREEK THEATRE FOOD AND BEVERAGE CONCESSION
(CON-XXX-XXX)**

It is the policy of the City to provide Minority Business Enterprise (MBE), Women Business Enterprise (WBE), Small Business Enterprise (SBE), Emerging Business Enterprise (EBE), Disabled Veteran Business Enterprise (DVBE), and all Other Business Enterprise (OBE) concerns an equal opportunity to participate in the performance of all City contracts.

Proposers will assist the City in implementing this policy by taking all reasonable steps to ensure that all available business enterprises, including MBEs, WBEs, SBEs, EBEs, DVBEs, and OBEs, have an equal opportunity to compete for, and participate in, City contracts. Equal opportunity will be determined by the proposer’s BIP outreach documentation, as described in Business Inclusion Program (BIP) Requirements (Section I.G of Exhibit D), of this RFP. Participation by MBEs, WBEs, SBEs, EBEs, DVBEs, and OBEs may be in the form of subcontracting. Proposers must refer to Business Inclusion Program (BIP) Requirements (Section I.G of Exhibit D) of this RFP for additional information and instructions. BIP outreach must be performed using the Business Assistance Virtual Network (www.labavn.org). A proposer’s failure to utilize and complete their BIP Outreach as described in Business Inclusion Program (BIP) Requirements (Section I.G of Exhibit D) may result in their proposal being deemed non-responsive.

The anticipated participation levels are as follows:

MBE Participation:	<u>18%</u>
WBE Participation:	<u>4%</u>
SBE Participation:	<u>25%</u>
EBE Participation:	<u>8%</u>
DVBE Participation:	<u>3%</u>

- h. Municipal Lobbying Ordinance / Bidder Certification – City Ethics Commission (CEC) Form 50 (Section I.H of Exhibit B) Please read the instructions in Exhibit D.
- i. Compliance with Los Angeles City Charter Section 470(c)(12) (Measure H) Please read the instructions in Exhibit H.
- j. Compliance with First Source Hiring Ordinance Please read the instructions in Exhibit I.
- k. Federal Tax ID Number and Form W-9 Please submit your Federal Tax ID Number with the proposal. The name on either document must match the proposer’s legal business name, as listed on the Proposer’s Signature Declaration and Affidavit.

**REQUEST FOR PROPOSALS
FOR THE OPERATION AND MAINTENANCE OF THE
GREEK THEATRE FOOD AND BEVERAGE CONCESSION
(CON-XXX-XXX)**

Complete and submit an original Form W-9 with your proposal (Section I.I of Exhibit D). The name on the W-9 must match the proposer's legal business name, as listed on the Proposer's Signature Declaration and Affidavit.

Only the proposer selected for award of this agreement shall submit the following additional required items prior to execution of the Agreement (within forty-five [45] calendar days from the date the agreement is awarded by the Board to the selected proposer):

- l. Americans with Disabilities Act Certification
- m. Business Tax Registration Certificate
- n. Certification of Compliance with Child Support Obligations
- o. Contractor Responsibility Ordinance – Pledge of Compliance
- p. City-approved Proof of Insurance
- q. City-approved Performance Deposit
- r. Los Angeles Residence Information (location of selected concessionaire's headquarters and percentage of workforce residing in Los Angeles)
- s. LWO/SCWRO – additional related forms from item 4.d. above
- t. Slavery Disclosure Affidavit
- u. First Source Hiring Ordinance – FSHO-1
- v. Good Food Purchasing Pledge

Failure of the selected proposer to submit all the required documents (specified as items "l" through "v" above) and submit a signed Agreement within forty-five (45) calendar days from the date the contract is awarded by the Board shall cause the proposal to be deemed non-responsive, and a penalty of One Hundred Dollars (\$100.00) per calendar day shall be applied and deducted from the Proposal Deposit. If, after ninety (90) calendar days from the date the contract is awarded by the Board, the contract is not signed and compliance documents not submitted and received by the Board Office, the City maintains the right to move on to the proposer with the next highest selection ranking.

2. Background and Experience

Describe your business entity's background and experience in providing food and beverage services at large venues such as the Greek Theatre. If this is a new company, partnership, or joint venture formed for the operation of this Concession, describe the background and qualifications of each of the partners or principals.

Each proposer and subcontractors must have a minimum qualifying experience of providing food and beverage services for a minimum of ten (10) different concert venues with a minimum seating capacity of five-thousand (5,000) per venue. A qualifying venue could be a theater, stadium or amphitheater.

**REQUEST FOR PROPOSALS
FOR THE OPERATION AND MAINTENANCE OF THE
GREEK THEATRE FOOD AND BEVERAGE CONCESSION
(CON-XXX-XXX)**

Note: This section pertains to your business entity's PAST experience and CURRENT operations, not your PROPOSED operation for this Concession.

2.1 Ownership Description

Proposers must include a response to each proposal item listed below:

- 2.1.1 ___ Address
- 2.1.2 ___ Length in business (in years and months)
- 2.1.3 ___ Type: Sole Proprietorship, Partnership, Joint Venture, Corporation or a limited liability company (LLC), etc.
- 2.1.4 ___ Size of company (includes total number of employees and annual gross revenue)
- 2.1.5 ___ Organizational chart
- 2.1.6 ___ Names of persons responsible for operations
- 2.1.7 ___ Any pending mergers (if none, so state in response to this section)
- 2.1.8 ___ Ownership information for all proposed subcontractors

2.2 Description of proposing entity's experience in and knowledge of operating and managing similar venues.

This section pertains to your business entity's PAST experience and CURRENT operations, not your PROPOSED operation for this RFP.

Proposers must include a response to each proposal item listed below (if none, so state in response to each item below):

- 2.2.1 ___ Description of similar current and past operations;
- 2.2.2 ___ Revenues of past or current comparable operations under the proposer's management, broken down by category (food, non-alcoholic beverages, alcoholic beverages etc.), for the previous five years (if applicable).
- 2.2.3 ___ Proposer's years of above experience.
- 2.2.4 ___ Extent of any related experience.
- 2.2.5 ___ Additional information that demonstrates your qualifications

2.3 Contracts History (include contact information for all contracts listed):

Proposers must include a response to each proposal item listed below (if none, so state in response to each item below):

- 2.3.1 ___ List of all contracts commenced and terminated, for whatever reasons, during most recent twelve (12) months, along with an explanation of the reasons for the termination.
- 2.3.2 ___ List of all contracts which terminated during 2014, along with an explanation of the reasons for the termination.

2.4 Current Operations

Proposers must include a response to each proposal item listed below (if none, so state in response to each item below):

- 2.4.1 ___ Employee hiring, training, motivation, and promotion policies.

**REQUEST FOR PROPOSALS
FOR THE OPERATION AND MAINTENANCE OF THE
GREEK THEATRE FOOD AND BEVERAGE CONCESSION
(CON-XXX-XXX)**

2.4.2 ___ Methods and controls for accounting.

2.5 References

Proposers must include a response to each proposal item listed below:

2.5.1 ___ Business References: Provide a minimum of three (3) references with whom you have conducted business to verify relevant past performance. Include names, addresses, telephone numbers, and the scope of the business relationship.

5.5.2 ___ Financial References: Provide a minimum of three (3) references from banks or other financial institutions; include names, addresses, telephone numbers, and the type of relationship (for example, checking/savings accounts, commercial loans, landlord, lessor, etc.)

3. Financial Capacity

Each proposer must demonstrate the financial means and resources to finance, operate, and sustain the Concession operation as proposed, including start-up and pre-opening costs, inventory and sufficient working capital, and access to additional capital, if needed. To this end, each proposer must provide, with the submitted proposal, the following items. All items submitted are subject to verification by the Department.

3.1 Good Standing

No qualified opinion in the audited financial statements, including “going concern “issues

3.2 Amount of Investment Required

State the amount of investment you will require to begin operations as proposed. This amount must include Start-Up Costs (Proposers must include a response to each proposal item listed below):

3.2.1 Amount of Investment to begin operations as proposed (to include):

- ___ Performance Deposit
- ___ Inventory
- ___ Equipment
- ___ Operating Supplies
- ___ Improvements
- ___ Others (list)

The amount stated here must be consistent with the proposer’s Financial Projections and Planning, which is to be completed in response to Section I on Page 5 of the RFP.

3.3 Source(s) of Funding Concession Operation

Proposers must include a response to each proposal item listed below:

3.3.1 ___ Indicate whether the proposed source of funding the above amount is cash reserves, financing from a commercial lender, other sources, or a combination thereof.

**REQUEST FOR PROPOSALS
FOR THE OPERATION AND MAINTENANCE OF THE
GREEK THEATRE FOOD AND BEVERAGE CONCESSION
(CON-XXX-XXX)**

3.3.2 ___ Of the total amount required, indicate the amount that is to be funded through each source.

3.4 Financial Documentation

Each proposer must provide, with the proposal, the following written verification of its ability and commitment to provide adequate funding in the amount indicated above.

(If a partnership or joint venture, the following must be provided for each of the entities comprising the partnership or joint venture.)

Proposers must include a response to each proposal item listed below:

3.4.1 If cash reserves are to be used to fund the operation, provide the following (If no cash is to be used, so state in your response to this section):

___ Bank statements for the proposing entity for the twelve (12) months preceding the release date of this RFP.

___ If proposing entity is a public corporation, include a letter signed by an officer of the company that represents that company's finance committee or other entity (executive committee, board of directors, etc.) that has the authority to approve the expenditures.

NOTE: Such letter must be an original and must be notarized.

___ Copies of current credit reports/ratings of the proposing entity. If private capital is to be used, provide copies of current credit reports/ratings of the person(s) whose funds are to be used ("Current" shall mean current as of April 2015 or later).

3.4.2 If loans are to be used to fund the operation, provide the following (if no loans are to be used, so state in your response to this section):

___ A copy of an unconditional, formal letter of commitment from the lender(s);

___ Copies of current credit reports/ratings of the proposing entity. ("Current" shall mean current as of April 2015 or later)

3.4.3 Provide detailed documentation for any additional sources of funding. If no other sources of funding are to be used other than those already indicated, so state in your response to this section.



CITY OF LOS ANGELES
DEPARTMENT OF RECREATION AND PARKS

EXHIBIT F

COMPLIANCE DOCUMENTS

REQUEST FOR PROPOSALS

Rctvpgtuj kr "cpf "Tgxgpgw'Dtcpej

Concessions Unit

572"UOI tcpf "Cx0"69yj "Ht0"

Mail Stop 625-26

Los Angeles, CA 90093

Telephone: (213) 202-3280

Fax: (213) 202-4311

Web: www.laparks.org/proposal.htm

Cr tki'4237



CITY OF LOS ANGELES
DEPARTMENT OF RECREATION AND PARKS

COMPLIANCE DOCUMENTS – REQUEST FOR PROPOSALS

TABLE OF CONTENTS

SECTION I – Compliance Documents to be submitted by Proposers with Proposals

- A. Proposer’s Signature Declaration and Affidavit
- B. Disposition of Proposals
- C. Affirmative Action Plan
- D. Contractor Responsibility Ordinance Statement
- E. Equal Benefits Ordinance Statement
- F. Living Wage Ordinance (LWO) / Service Contractor Worker Retention Ordinance (SCWRO)
- G. Business Inclusion Program
- H. Municipal Lobbying Ordinance / Bidder Certification – CEC Form 50
- I. Form W-9, Request for Taxpayer Identification Number (TIN) and Certification

SECTION II – Compliance Documents to be submitted by Selected Proposer

- J. Americans with Disabilities Act Certification
- K. Business Tax Registration Certificate
- L. Certification of Compliance with Child Support Obligations
- M. Contractor Responsibility Ordinance – Pledge of Compliance
- N. City-Approved Proof of Insurance (*See separate exhibit attached to RFP*)
- O. City-Approved Performance Deposit (*See RFP for acceptable forms of deposit*)
- P. Los Angeles Residence Information
- Q. Living Wage Ordinance (LWO) / Service Contractor Worker Retention Ordinance (SCWRO) – Additional Forms
- R. Slavery Disclosure Affidavit



CITY OF LOS ANGELES
DEPARTMENT OF RECREATION AND PARKS

SECTION I

Compliance Documents to be submitted by Proposers with Proposals

PROPOSER'S SIGNATURE DECLARATION AND AFFIDAVIT

SECTION A**PROPOSER'S SIGNATURE DECLARATION AND AFFIDAVIT**

With each proposal, a statement shall be submitted and signed by the respondent under penalty of perjury that: The response is genuine, not a sham or collusive, the response is not made in the interest or on behalf of any person not named therein; the respondent has not directly or indirectly induced or solicited any person to submit a false or sham response or to refrain from responding; and, the respondent has not in any manner sought by collusion to secure an advantage over any other respondent.

INSTRUCTIONS:

- a. Sign and Notarize the Document
- b. Submit with the Bid/Proposal

Signatures:

Individual: (e.g., Individual dba [Name or Company], etc) – Individual must sign affidavit.

Partnership: At least ONE General Partner must sign the affidavit.

Corporation: It is preferred that the **PRESIDENT** and **SECRETARY** of the corporation sign the affidavit on behalf of the corporation, but a **VICE-PRESIDENT** may sign in the absence of the President and an Assistant Secretary or Treasurer may sign in the absence of the Secretary.

Note: An Authorized Agent may sign for a Corporation, provided the City is furnished a certified copy of the Board of Directors Resolution authorizing such person to execute the document on behalf of the corporation. An acknowledgement at the base of the Resolution must state it is unchanged, in force, and be signed by the Corporate Secretary with the current date.

AFFIDAVIT TO ACCOMPANY PROPOSALS

I/We, _____

being first duly sworn, deposes and states: That the undersigned

(Insert "Sole Owner", "General Partner", "President", "Secretary", or other proper title)

is of _____
(Name of firm / business entity)

Who submits herewith to City of Los Angeles the attached proposal:

Affiant deposes and states: That said proposal is genuine; that the same is not sham or collusive; that all statements of fact therein are true; that such proposal was not made in the interest or behalf of any person, partnership, company, association, organization or corporation not therein named or disclosed.

Affiant deposes and states: That the proposer has not directly or indirectly by agreement, communication or conference with anyone attempted to induce action prejudicial to the interests of the public body which is to award the contract, or of any other proposer, or anyone else interested in the proposed contract: that the proposer has not in any manner sought by collusion to secure for itself an advantage over any other proposer.

Affiant further deposes and states that prior to the public opening and reading of proposals the said proposer:

- (a) Did not, directly or indirectly, induce or solicit anyone else to submit a false or sham proposal;
- (b) Did not, directly or indirectly, collude, conspire, connive or agree with anyone else that said proposer or anyone else or fix the proposal price of said proposer or of anyone else, or to raise or fix any overhead, profit or cost element of its price or of that of anyone else;
- (c) Did not, directly or indirectly, submit its proposal price or any breakdown thereof, or the contents thereof, or divulge information or data relative thereto, to any corporation, partnership, company, association, organization, proposal depository, or to any member or agent thereof, or to any individual or group of individuals, except to the awarding authority or to any person or persons who have a partnership or other financial interest with said proposer in its business.

I understand and agree that any falsification in the affidavit will be grounds for rejection of this proposal or cancellation of any concession contract awarded pursuant to this proposal.

I hereby certify or declare under penalty of perjury under the laws of the State of California that the foregoing is true and correct.

STATE OF CALIFORNIA
COUNTY OF _____

Subscribed and sworn to before me this _____ day of _____
(Signature)

(Month / Year) (Title)

(Notary Public) (Date)

PROPOSALS WILL NOT BE CONSIDERED UNLESS THE AFFIDAVIT HEREON IS FULLY EXECUTED, INCLUDING THE CERTIFICATE OF THE NOTARY AND THE NOTARIAL SEAL

DISPOSITION OF PROPOSALS

SECTION B**DISPOSITION OF PROPOSALS**

All proposals submitted in response to the RFP shall become the property of the City of Los Angeles and a matter of public record. Proposers must identify all copyrighted material, trade secrets, or other proprietary information that they claim are exempt from disclosure under the Public Records Act, and indemnify and defend the City of Los Angeles for its refusal to disclose such material from person making a request therefore.

INSTRUCTIONS:

- a. Sign the Document
- b. Submit with the Bid/Proposal

Signatures:

The person signing must be authorized to bind the proposer.

Disposition of Proposals

All proposals submitted in response to the RFP shall become the property of the City of Los Angeles and a matter of public record. Proposers must identify all copyrighted materials, trade secrets, or other proprietary information that they claim are exempt from disclosure under the Public Records Act (California Code, Section 6250 et seq.)

In the event such an exemption is claimed, the proposer must state in the proposal that the proposer will defend any action brought against the City for its refusal to disclose such material, trade secret, or other proprietary information to any party making such a request. The proposer is required to state in the proposal that:

“The proposer will indemnify the City or Agency and hold it harmless from any claim or liability and defend any action brought against the City of Los Angeles for its refusal to disclose copyrighted material, trade secrets, or other proprietary information to any persons making a request therefore.”

Proposer’s obligations herein include, but are not limited to, all attorney’s fees (both in house and outside counsel), costs of litigation incurred by the City or its attorneys (including all actual costs incurred by the City, not merely those costs recoverable by a prevailing party, and specifically including costs of experts and consultants) as well as all damages or liability or any nature whatsoever arising out of any such suits, claims, and causes of action brought against the City, through and including any appellate proceedings. Proposer’s obligations to the City under this indemnification provision shall be due and payable on a monthly, on-going basis within thirty (30) days after each submission to Proposer of the City’s invoices for all fees and costs incurred by the City, as well as all damages or liability of any nature.

“I have read and understand the Disposition of Proposals and agree that the City of Los Angeles may release any materials and information contained in the proposal submitted by the undersigned’s firm in the event that the required hold harmless statement is not included in the Proposal.”

Signature of person authorized to bind proposer

Date

AFFIRMATIVE ACTION PLAN

SECTION C**AFFIRMATIVE ACTION PLAN**

Los Angeles Administrative Code (LAAC), Division 10, Chapter 1, Section 10.8 establishes a Nondiscrimination / Affirmative Action Program requirement for all vendors doing business with the City of Los Angeles.

Bidders/Proposers are advised that any contract awarded pursuant to this procurement process shall be subject to the applicable provisions of Los Angeles Administrative Code Section 10.8.2., Non-discrimination Clause.

Questions pertaining to this requirement should be directed to the Office of Contract Compliance at (213) 847-1922. Bidders/Proposers seeking additional information regarding the requirements of the City's Non-Discrimination Clause, Equal Employment Practices and Affirmative Action Program may visit the Bureau of Contract Administration's web site at <http://bca.lacity.org>.

INSTRUCTIONS:

- a. Non-construction services to or for the City for which the consideration is \$1,000 or more shall comply with the provisions of Los Angeles Administrative Code Sections 10.8.3., Equal Employment Practices Provisions. All Bidders/Proposers shall complete and upload the Non-Discrimination/Equal Employment Practices Certification (two [2] pages) available on the City of Los Angeles' Business Assistance Virtual Network (BAVN) residing at www.labavn.org at the time it registers on BAVN but no later than the time when an individual Bid/Proposal is submitted. However, Bidders/Proposers with Certifications previously uploaded to BAVN and verified by the Office of Contract Compliance (OCC) do not need to re-submit.
- b. Non-construction services to or for the City for which the consideration is \$100,000 or more shall comply with the provisions of Los Angeles Administrative Code Sections 10.8.4., Affirmative Action Program Provisions. All Bidders/Proposers shall complete and upload the City of Los Angeles Affirmative Action Plan (four [4] pages) available on the City of Los Angeles' Business Assistance Virtual Network (BAVN) residing at www.labavn.org at the time it registers on BAVN but no later than the time when an individual Bid/Proposal is submitted.
- c. Bidders/Proposers opting to submit their own Affirmative Action Plan may do so by uploading their Affirmative Action Plan onto the City's BAVN. Bidders/Proposers with current OCC approval for their Affirmative Action Plan do not need to re-submit unless the approval is 30 days or less from expiration.

Furthermore, subject subcontractors shall be required to submit the Non-Discrimination/Equal Employment Practices Certification and Affirmative Action Plan to the successful Bidder/Proposer prior to commencing work on the contract. The subcontractors' Non-Discrimination/Equal Employment Practices Certification(s) and Affirmative Action Plan(s) shall be retained by the successful Bidder/Proposer and shall be made available to the Office of Contract Compliance upon request.

Both the Non-Discrimination/Equal Employment Practices Affidavit and the City of Los Angeles Affirmative Action Plan Affidavit shall be effective for a period of twelve months from the date it is first uploaded onto the City's BAVN.

CONTRACTOR RESPONSIBILITY ORDINANCE STATEMENT

SECTION D**CONTRACTOR RESPONSIBILITY ORDINANCE STATEMENT**

The Contractor Responsibility Ordinance (CRO) requires a determination, via the CRO questionnaire, that prospective contractors are responsible and capable of fully performing the work before a contract is awarded by the City of Los Angeles. Additional information may be found at the following website:

{ HYPERLINK "http://bca.lacity.org/index.cfm?nxt=soo&nxt_body=content_cro.cfm" }

INSTRUCTIONS:

- a. The questionnaire must be completed, appropriately signed, and submitted with the proposal (Pages 1 through 9).

CITY OF LOS ANGELES CONTRACTOR RESPONSIBILITY ORDINANCE (Los Angeles Administrative Code Section 10.40 et seq.)

1. What is the Contractor Responsibility Ordinance?

The Contractor Responsibility Ordinance (CRO) requires that each department make a determination as to whether prospective contractors are responsible and capable of fully performing the work before being awarded a City contract. The Ordinance also requires prospective contractors to complete a Responsibility Questionnaire that will be posted on the internet for 14 calendar days for public review.

2. When was the Ordinance adopted?

The City Council adopted the CRO on November 21, 2000. Regulations implementing the Ordinance were adopted on June 19, 2001.

3. Who is responsible for the administration and enforcement of the Ordinance?

Three departments were named as administrative agencies responsible for the administration of the CRO. Each Designated Administrative Agency (DAA) administers the Ordinance for a specific type of agreement. The three DAA's, the type of agreement each DAA is responsible for, and contact information for each DAA is provided in the table below.

Administrative Agency	Agreement Type	Contact Information
Public Works, BCA	Service	Russ Strazella (213) 580-5012
Public Works, BCA	Construction	Russ Struzella (213) 580-5012
General Services	Procurement	Raymond Richards (213) 485-4591

4. Are all service, procurement, and construction agreements subject to the CRO?

Generally, an agreement, including one processed as an Authorization for Expenditure (AFE) with a Letter of Agreement, is covered by the CRO if it meets one of the definitions below.

Service agreements: Agreements covered under the general category of a "service agreement" include:

- An agreement for \$25,000.00 or more and for at least three months in which a contractor will provide services to or for the City.
- An agreement for a lease or license of City property if the service to be performed on the property is something that City employees could perform.
- An agreement for the lease or license of City property that is in a location where a substantial number of the general public might visit.
- An agreement for the grant of City financial assistance for \$100,000 or more if the agreement is for the purpose of economic development or job growth. City financial

assistance may also include loans if certain conditions are met. (Refer to Sec. 10.40.0(b) of the CRO.)

Purchase agreements: Purchase agreements are covered if they are for \$100,000 or more. Agreements to purchase garments are covered if they are for \$25,000 or more.

Construction agreements: All construction agreements are covered, regardless of amount or term.

5. When did the Ordinance become applicable?

The Ordinance is being applied to Invitations for Bids (IFB) (including Requests for Proposals, Requests for Qualifications, "sole-sourced" contracts, and any other procurement process) released to the public **on or after September 4, 2001**. An agreement entered into as a result of an IFB released prior to that date is not subject to the CRO unless it is amended after September 4, 2001, and the amended agreement meets the definitions stated in the answer to Question #4 above.

6. If an IFB is subject to the CRO, what must a department do?

The department must inform prospective bidders/proposers that the CRO is applicable to the IFB. The department must also include the appropriate Responsibility Questionnaire for bidders/proposers to fill out. Depending on the type of contract to be awarded, one of three Questionnaires may be included in the IFB: Service; Procurement; and Construction.

7. What is a Responsibility Questionnaire?

The Responsibility Questionnaire asks for information about the bidder/proposer: business organization or structure; financial resources and responsibility; performance history; prior disputes; and history in complying with laws. Before a department awards a contract, the department will consider information contained in the Questionnaire as part of the review of a bidder/proposer's responsibility, as well as any information contained in the Office of Contract Compliance's Contractor Evaluation database [<http://caodocs.ci.la.ca.us/ContEval/>] regarding the proposer's prior performance on City contracts.

8. What must a bidder/proposer do when responding to an IFB?

If the IFB is subject to the CRO, the bidder/proposer must complete the Responsibility Questionnaire and return it to the City department with the bid/proposal. If a bidder/proposer does not submit a completed Questionnaire with the bid/proposal, the City department may consider the bidder/proposer to be non-responsive to the IFB and may disqualify the bidder/proposer from the rest of the IFB process.

9. Is a separate Questionnaire required for each IFB?

Unless the IFB is exempt, a separate Questionnaire must be submitted for each IFB to which a bidder/proposer responds.

10. What will the City do with the Questionnaire?

The department responsible for awarding the agreement will review the information contained in the submitted questionnaires, and if necessary, follow up with the bidder/proposer to clarify any information contained in the Questionnaire. The awarding authority will send the completed Questionnaires to the appropriate DAA. The DAA will post the Questionnaires on the City's Bidder/Contractor Responsibility website: www.lacity.org/bidresp. This posting also applies to "sole-sourced" contracts, so the completed Questionnaire from a proposed "sole-sourced" contractor must be forwarded to the appropriate DAA for posting.

11. How long will the Questionnaires be posted?

The Questionnaires will be posted on the internet for 14 calendar days. Unless an exemption applies, a department cannot award an agreement until the posting requirement has been met.

12. What happens during the 14 calendar-day posting period?

The general public will be able to review the Questionnaires posted. If, during the 14 calendar-day posting period, the DAA receives information that calls into question a bidder/proposer's responsibility, the DAA will investigate the matter. In that case, no agreement may be awarded until the DAA finishes its investigation. Information obtained during the investigation will be provided to the department to consider in its determination of a bidder/proposer's responsibility.

13. How does a department know that the posting requirement has been met?

The awarding department should complete the top portion of the Posting Verification Form and forward it to the DAA along with the Questionnaires. The DAA will complete the bottom portion of the Posting Verification Form and return it to the department when the posting requirement has been met.

14. Are contract amendments subject to the CRO?

If an agreement is amended after September 4, 2001, and the amended agreement meets the definitions stated in the answer to Question #4 above, it is subject to the CRO. Contractors do not have to submit a Questionnaire; however, the CRO Contract Language must be incorporated into the amended agreement.

15. After the agreement is awarded, or the agreement is amended, what does the CRO require the contractor to do?

The CRO requires a contractor to:

- Comply with all federal, state, and local laws in the performance of the contract, including but not limited to laws regarding health and safety, labor and employment, wage and hours, and licensing laws, which affect employees.

- Notify the awarding authority within 30 calendar days after receiving notice that any governmental agency has started an investigation into violations of, or has found that the contractor has violated, any federal, state, or local law in the performance of the contract..
- When applicable, provide the awarding authority, within 30 calendar days, updated responses to the Questionnaire if a change occurs that would affect the contractor's responsibility and ability to continue the agreement.
- Ensure that subcontractors working on the City agreement comply with all federal, state, and local laws in the performance of the agreement.
- Ensure that subcontractors working on the City agreement submit a Pledge of Compliance to comply with the CRO.

16. What happens if a contractor is found to be in violation of the Ordinance?

The DAA will notify the contractor that a violation has been found and give the contractor 10 calendar days to correct the violation. If the contractor fails to do so, the City may terminate the agreement and pursue all available contractual remedies. The City may also hold a non-responsibility hearing and debar the contractor from doing business with the City for five (5) years.

17. What about subcontractors?

Subcontractors are subject to the CRO, and the contractor must ensure that each of its subcontractors complies with the CRO. Subcontractors do not need to complete a Questionnaire, but they must submit to the awarding department a Pledge of Compliance with the Ordinance before they can start work on a City agreement.

18. What if a subcontractor is found to be in violation of the Ordinance?

Because the prime contractor is responsible for ensuring that all its subcontractors comply with the CRO, the sanctions listed in the answer to Question #16 may be applied to the prime contractor if the subcontractor does not correct the violation(s).

19. Are there any exemptions under the Ordinance?

Generally, two categories of exemptions exist under the CRO:

(1) Agreements exempt from all the CRO requirements:

- Contracts with a governmental entity such as the United States of America, the State of California, a county, city or public agency of such entities, or a public or quasi-public corporation located therein and declared by law to have such status.
- Contracts for the investment of trust moneys or agreements relating to the management of trust assets.
- Banking contracts entered into by the Treasurer pursuant to California Government Code Section 53630 et seq.

(2) Agreements that are only exempt from the requirement that a bidder/proposer submit a Questionnaire. The contractor must still comply with all other CRO provisions.

- Agreements awarded on the basis of emergency circumstances when the awarding authority finds that the City would suffer a financial loss or that City operations would be adversely impacted. This exemption is subject to approval by the DAA.
- Agreements for goods or services that are proprietary or available from only one source. This exemption is subject to approval by the DAA.
- Agreements awarded under the authority of Charter Sections 371(e)(5), (6), (7) or (8). The awarding authority must certify in writing that the contract is entered into in compliance with the requirements of those Charter sections.

20. Where can I obtain a copy of the Contractor Responsibility Ordinance and the Rules and Regulations?

All CRO-related information and documents can be found on the CRO website:
<http://www.lacity.org/bidresp>.

**CITY OF LOS ANGELES
RESPONSIBILITY QUESTIONNAIRE**

RESPONSES TO THE QUESTIONS CONTAINED IN THIS QUESTIONNAIRE MUST BE SUBMITTED ON THIS FORM. In responding to the Questionnaire, neither the City form, nor any of the questions contained therein, may be retyped, recreated, modified, altered, or changed in any way, in whole or in part. Bidders or Proposers that submit responses on a form that has been retyped, recreated, modified, altered, or changed in any way shall be deemed non-responsive.

The signatory of this Questionnaire guarantees the truth and accuracy of all statements and answers to the questions herein. Failure to complete and return this questionnaire, any false statements, or failure to answer (a) question(s) when required, may render the bid/proposal non-responsive. All responses must be typewritten or printed in ink. Where an explanation is required or where additional space is needed to explain an answer, use the Responsibility Questionnaire Attachments. Submit the completed form and all attachments to the awarding authority. Retain a copy of this completed form for future reference. Contractors must submit updated information to the awarding authority if changes have occurred that would render any of the responses inaccurate in any way. Updates must be submitted to the awarding authority within 30 days of the change(s).

A. CONTACT INFORMATION

CITY DEPARTMENT INFORMATION

City Department/Division Awarding Contract

City Contact Person

Phone

City Bid or Contract Number (if applicable) and Project Title

BIDDER/CONTRACTOR INFORMATION

Bidder/Proposer Business Name

Street Address

City

State

Zip

Contact Person, Title

Phone

Fax

TYPE OF SUBMISSION:

The Questionnaire being submitted is:

- An initial submission of a completed Questionnaire.
- An update of a prior Questionnaire dated ____/____/____.
- No change. I certify under penalty of perjury under the laws of the State of California that there has been no change to any of the responses since the last Responsibility Questionnaire dated ____/____/____ was submitted by the firm. Attach a copy of that Questionnaire and sign below.

Print Name, Title

Signature

Date

TOTAL NUMBER OF PAGES SUBMITTED, INCLUDING ALL ATTACHMENTS: _____

B. BUSINESS ORGANIZATION/STRUCTURE

Indicate the organizational structure of your firm. "Firm" includes a sole proprietorship, corporation, joint venture, consortium, association, or any combination thereof.

Corporation: Date incorporated: ____/____/____ State of incorporation: _____

List the corporation's current officers.

President: _____

Vice President: _____

Secretary: _____

Treasurer: _____

Check the box only if your firm is a publicly traded corporation.

List those who own 5% or more of the corporation's stocks. Use Attachment A if more space is needed. Publicly traded corporations need not list the owners of 5% or more of the corporation's stocks.

Limited Liability Company: Date of formation: ____/____/____ State of formation: _____

List members who own 5% or more of the company. Use Attachment A if more space is needed.

Partnership: Date formed: ____/____/____ State of formation: _____

List all partners in your firm. Use Attachment A if more space is needed.

Sole Proprietorship: Date started: ____/____/____

List any firm(s) that you have been associated with as an owner, partner, or officer for the last five years. Use Attachment A if more space is needed. Do not include ownership of stock in a publicly traded company in your response to this question.

Joint Venture: Date formed: ____/____/____

List: (1) each firm that is a member of the joint venture and (2) the percentage of ownership the firm will have in the joint venture. Use Attachment A if more space is needed. **Each member of the Joint Venture must complete a separate Questionnaire for the Joint Venture's submission to be considered as responsive to the invitation.**

C. OWNERSHIP AND NAME CHANGES

1. Is your firm a subsidiary, parent, holding company, or affiliate of another firm?

Yes No

If **Yes**, explain on Attachment A the relationship between your firm and the associated firms. Include information about an affiliated firm only if one firm owns 50% or more of another firm, or if an owner, partner or officer of your firm holds a similar position in another firm.

2. Has any of the firm's owners, partners, or officers operated a similar business in the past five years?

Yes No

If **Yes**, list on Attachment A the names and addresses of all such businesses, and the person who operated the business. Include information about a similar business only if an owner, partner or officer of your firm holds a similar position in another firm.

3. Has the firm changed names in the past five years?

Yes No

If **Yes**, list on Attachment A all prior names, addresses, and the dates they were used. Explain the reason for each name change in the last five years.

4. Are any of your firm's licenses held in the name of a corporation or partnership?

Yes No

If Yes, list on Attachment A the name of the corporation or partnership that actually holds the license.

Bidders/Contractors must continue on to Section D and answer all remaining questions contained in this Questionnaire.

The responses to the remaining questions in this Questionnaire will not be posted on the internet but will be made available to the public for review upon request. Contact the appropriate Designated Administrative Agency.

D. FINANCIAL RESOURCES AND RESPONSIBILITY

5. Is your firm now, or has it ever been at any time in the last five years, the debtor in a bankruptcy case?

Yes No

If **Yes**, explain on Attachment B the circumstances surrounding each instance.

6. Is your company in the process of, or in negotiations toward, being sold?

Yes No

If **Yes**, explain the circumstances on Attachment B.

E. PERFORMANCE HISTORY

7. How many years has your firm been in business? _____ Years.

8. Has your firm ever held any contracts with the City of Los Angeles or any of its departments?

Yes No

If, **Yes**, list on an Attachment B all contracts your firm has had with the City of Los Angeles for the last 10 years. For each contract listed in response to this question, include: (a) entity name; (b) purpose of contract; (c) total cost; (d) starting date; and (e) ending date.

9. List on Attachment B all contracts your firm has had with any private or governmental entity (other than the City of Los Angeles) over the last five years that are similar to the work to be performed on the contract for which you are bidding or proposing. For each contract listed in response to this question, include: (a) entity name; (b) purpose of contract; (c) total cost; (d) starting date; and (e) ending date.

Check the box if you have not had any similar contracts in the last five years

10. In the past five years, has a governmental or private entity or individual terminated your firm's contract prior to completion of the contract?

Yes No

If **Yes**, explain on Attachment B the circumstances surrounding each instance.

11. In the past five years, has your firm used any subcontractor to perform work on a government contract when you knew that the subcontractor had been debarred by a governmental entity?

Yes No

If **Yes**, explain on Attachment B the circumstances surrounding each instance.

12. In the past five years, has your firm been debarred or determined to be a non-responsible bidder or contractor?

Yes No

If **Yes**, explain on Attachment B the circumstances surrounding each instance.

F. DISPUTES

13. In the past five years, has your firm been the defendant in court on a matter related to any of the following issues? For parts (a) and (b) below, check **Yes** even if the matter proceeded to arbitration without court litigation. For part (c), check **Yes** only if the matter proceeded to court litigation. If you answer **Yes** to any of the questions below, explain the circumstances surrounding each instance on Attachment B. You must include the following in your response: the name of the plaintiffs in each court case, the specific causes of action in each case; the date each case was filed; and the disposition/current status of each case.

(a) Payment to subcontractors?

Yes **No**

(b) Work performance on a contract?

Yes **No**

(c) Employment-related litigation brought by an employee?

Yes **No**

14. Does your firm have any outstanding judgements pending against it?

Yes **No**

If **Yes**, explain on Attachment B the circumstances surrounding each instance.

15. In the past five years, has your firm been assessed liquidated damages on a contract?

Yes **No**

If **Yes**, explain on Attachment B the circumstances surrounding each instance and identify all such projects, the amount assessed and paid, and the name and address of the project owner.

G. COMPLIANCE

16. In the past five years, has your firm or any of its owners, partners or officers, ever been investigated, cited, assessed any penalties, or been found to have violated any laws, rules, or regulations enforced or administered, by any of the governmental entities listed on Attachment C (Page 9)? For this question, the term "owner" does not include owners of stock in your firm if your firm is a publicly traded corporation.

Yes **No**

If **Yes**, explain on Attachment B the circumstances surrounding each instance, including the entity that was involved, the dates of such instances, and the outcome.

17. If a license is required to perform any services provided by your firm, in the past five years, has your firm, or any person employed by your firm, been investigated, cited, assessed any penalties, subject to any disciplinary action by a licensing agency, or found to have violated any licensing laws?

Yes **No**

If **Yes**, explain on Attachment B the circumstances surrounding each instance in the last five years.

18. In the past five years, has your firm, any of its owners, partners, or officers, ever been penalized or given a letter of warning by the City of Los Angeles for failing to obtain authorization from the City for the substitution of a Minority-owned (MBE), Women-owned (WBE), or Other (OBE) business enterprise?

Yes **No**

If **Yes**, explain on Attachment B the circumstances surrounding each instance in the last five years.

H. BUSINESS INTEGRITY

19. For questions (a), (b), and (c) below, check **Yes** if the situation applies to your firm. For these questions, the term "firm" includes any owners, partners, or officers in the firm. The term "owner" does not include owners of stock in your firm if the firm is a publicly traded corporation. If you check **Yes** to any of the questions below, explain on Attachment B the circumstances surrounding each instance.

(a) Is a governmental entity or public utility currently investigating your firm for making (a) false claim(s) or material misrepresentation(s)?

Yes **No**

(b) In the past five years, has a governmental entity or public utility alleged or determined that your firm made (a) false claim(s) or material misrepresentation(s)?

Yes **No**

(c) In the past five years, has your firm been convicted or found liable in a civil suit for, making (a) false claim(s) or material misrepresentation(s) to any governmental entity or public utility?

Yes **No**

20. In the past five years, has your firm or any of its owners or officers been convicted of a crime involving the bidding of a government contract, the awarding of a government contract, the performance of a government contract, or the crime of fraud, theft, embezzlement, perjury, bribery? For this question, the term "owner" does not include those who own stock in a publicly traded corporation.

Yes **No**

If **Yes**, explain on Attachment B the circumstances surrounding each instance.

CERTIFICATION UNDER PENALTY OF PERJURY

I certify under penalty of perjury under the laws of the State of California that I have read and understand the questions contained in this questionnaire and the responses contained on all Attachments. I further certify that I have provided full and complete answers to each question, and that all information provided in response to this Questionnaire is true and accurate to the best of my knowledge and belief.

Print Name, Title

Signature

Date

ATTACHMENT A FOR SECTIONS A THROUGH C

Where additional information or an explanation is required, use the space below to provide the information or explanation. Information submitted on this sheet must be typewritten or printed in ink. Include the number of the question for which you are submitting additional information. Information submitted on this Attachment in response to Questions in Sections A through C will be posted on the internet for public review. Make copies of this Attachment if additional pages are needed.

Page _____

ATTACHMENT B FOR SECTIONS D THROUGH H

Where additional information or an explanation is required, use the space below to provide the information or explanation. Information submitted on this sheet must be typewritten or printed in ink. Include the number of the question for which you are submitting additional information. Information submitted on this Attachment in response to Questions in Sections D through H will not be posted on the internet but will be made available to the public for review upon request. Make copies of this Attachment if additional pages are needed.

Page _____

ATTACHMENT C: GOVERNMENTAL ENTITIES FOR QUESTION NO. 16

Check **Yes** in response to Question No. 16 if your firm or any of its owners, partners or officers, have ever been investigated, cited, assessed any penalties, or found to have violated any laws, rules, or regulations enforced or administered, by any of the governmental entities listed below (or any of its subdivisions), including but not limited to those examples specified below. The term “owner” does not include owners of stock in your firm if your firm is a publicly traded corporation. If you answered **Yes**, provide an explanation on Attachment B of the circumstances surrounding each instance, including the entity involved, the dates of such instances, and the outcome.

FEDERAL ENTITIES**Federal Department of Labor**

- American with Disabilities Act
- Immigration Reform and Control Act
- Family Medical Leave Act
- Fair Labor Standards Act
- Davis-Bacon and laws covering wage requirements for federal government contract workers
- Migrant and Seasonal Agricultural Workers Protection Act
- Immigration and Naturalization Act
- Occupational Safety and Health Act
- anti-discrimination provisions applicable to government contractors and subcontractors
- whistleblower protection laws

Federal Department of Justice

- Civil Rights Act
- American with Disabilities Act
- Immigration Reform and Control Act of 1986
- bankruptcy fraud and abuse

Federal Department of Housing and Urban Development (HUD)

- anti-discrimination provisions in federally subsidized/assisted/sponsored housing programs
- prevailing wage requirements applicable to HUD related programs

Federal Environmental Protection Agency

- Environmental Protection Act

National Labor Relations Board

- National Labor Relations Act

Federal Equal Employment Opportunity Commission

- Civil Rights Act
- Equal Pay Act
- Age Discrimination in Employment Act
- Rehabilitation Act
- Americans with Disabilities Act

STATE ENTITIES**California's Department of Industrial Relations**

- wage and labor standards, and licensing and registration
- occupational safety and health standards
- workers' compensation self insurance plans
- Workers' Compensation Act
- wage, hour, and working standards for apprentices
- any provision of the California Labor Code

California's Department of Fair Employment and Housing

- California Fair Employment and Housing Act
- Unruh Civil Rights Act
- Ralph Civil Rights Act

California Department of Consumer Affairs

- licensing, registration, and certification requirements
- occupational licensing requirements administered and/or enforced by any of the Department's boards, including the Contractors' State Licensing Board

California's Department of Justice**LOCAL ENTITIES**

City of Los Angeles or any of its subdivisions for violations of any law, ordinance, code, rule, or regulation administered and/or enforced by the City, including any letters of warning or sanctions issued by the City of Los Angeles for an unauthorized substitution of subcontractors, or unauthorized reductions in dollar amounts subcontracted.

OTHERS

Any other federal, state, local governmental entity for violation of any other federal, state, or local law or regulation relating to wages, labor, or other terms and conditions of employment.

EQUAL BENEFITS ORDINANCE STATEMENT

SECTION E**EQUAL BENEFITS ORDINANCE STATEMENT**

The Equal Benefits Ordinance (EBO) requires that any contract awarded pursuant to this procurement process shall be subject to the applicable provisions of Los Angeles Administrative Code Section 10.8.2.1, Equal Benefits Ordinance (EBO).

Bidders/Proposers seeking additional information regarding the requirements of the Equal Benefits Ordinance may visit the Bureau of Contract Administration's web site at www.bca.lacity.org.

INSTRUCTIONS:

- a. The selected bidder/proposer shall complete and upload the Equal Benefits Ordinance Affidavit (two [2] pages) available on the City of Los Angeles' Business Assistance Virtual Network (BAVN) residing at www.labavn.org at the time it registers on BAVN, but no later than the submittal due date designated by the Awarding Authority, and prior to award of a City contract valued at \$5,000. The Equal Benefits Ordinance Affidavit shall be effective for a period of twelve months from the date it is first uploaded onto the City's BAVN. Bidders/Proposers do not need to submit supporting documentation with their bids or proposals. However, the City may request supporting documentation to verify that the benefits are provided equally as specified on the Equal Benefits Ordinance Affidavit.

**LIVING WAGE ORDINANCE AND SERVICE CONTRACT
WORKER RETENTION ORDINANCE**

SECTION F
LIVING WAGE ORDINANCE
AND
SERVICE CONTRACT WORKER RETENTION ORDINANCE

Unless approved for an exemption, contractors under contracts primarily for the furnishing of services to or for the City and that involve an expenditure in excess of \$25,000 and a contract term of at least three (3) months, lessees and licensees of City property, and certain recipients of City financial assistance, shall comply with the provisions of Los Angeles Administrative Code Section 10.37 et seq., Living Wage Ordinance and 10.36 et seq. Service Contractor Worker Retention Ordinance. Additional information may be found at the following websites:

{ HYPERLINK "http://bca.lacity.org/index.cfm?nxt=lco&nxt_body=content_lwo.cfm" }

{ HYPERLINK "http://bca.lacity.org/index.cfm?nxt=soo&nxt_body=content_scwro.cfm" }

INSTRUCTIONS:

If applying for an exemption, complete and submit the appropriate exemption forms with the proposal; if no exemption is claimed, do not submit the forms with the proposal.

**CITY OF LOS ANGELES
LIVING WAGE ORDINANCE
(Los Angeles Administrative Code Section 10.37 et seq.)**

1. What is the Living Wage Ordinance?

The Living Wage Ordinance (LWO) requires employers who have agreements with the City to pay their employees at least a minimum “living wage” and to provide certain benefits. If the agreement is subject to the LWO, the employer must do the following:

- Pay employees working on the subject agreement a wage rate that is at least equal to the “living wage” rate. The “living wage” is adjusted annually and becomes effective July 1 of each year. Employers can obtain information about the living wage rate currently in effect by going to Department of Public Works, Bureau of Contract Administration, Office of Contract Compliance (OCC) website at www.lacity.org/bca/OCCmain.html.
- Provide employees with at least 12 paid days off per year for sick leave, vacation, or personal necessity; and at least 10 unpaid sick days off per year.
- Tell employees who make less than \$12.00 per hour that they may qualify for the federal Earned Income Tax Credit and provide them with the forms required to apply for the credit.
- Cooperate with the City by providing access to the work site and to payroll and related documents so that the City can determine if the employer is complying with the LWO.
- Pledge to comply with federal laws prohibiting an employer from retaliating against employees for union organizing.
- Not retaliate against any employee who makes claims about non-compliance with the LWO.

2. When was the Ordinance adopted?

The LWO was adopted in May, 1997 and amended in January, 1999.

3. What types of agreements are subject to the Ordinance?

Generally, the LWO covers the following types of agreements:

- An agreement in an amount over \$25,000.00 and for at least three months in which an employer will provide services to or for the City.
- An agreement for the lease or license of City property if the service being performed on the property is something that City employees would otherwise do.
- An agreement for the lease or license of City property that is in a location where a substantial number of the general public might visit.
- An agreement in which the City gives financial assistance for the purpose of promoting economic development or job growth.
- An agreement in which the City determines that applying the LWO would be in the best interest of the City.

4. Is an agreement subject to the LWO if it was entered into before May, 1997?

Agreements executed after May, 1997 are subject to the LWO. An agreement entered into before May, 1997 may become subject to LWO if it is later amended or modified in order to add time or money to the original agreement.

5. Are there any requirements that would apply to an employer who does not have an agreement with City that is subject to the LWO?

All employers are required to comply with the LWO's prohibition against retaliation, even if the employer does not have an agreement with the City that is subject to the Ordinance.

6. Are all employees covered by the Ordinance?

Intentionally left blank 8/18/06

7. Are an employer's subcontractors subject to the requirements of the Ordinance?

A subcontractor may be covered by the Ordinance if the subcontractor performs work on the subject agreement. If so, the subcontractor must also comply with the requirements of the LWO, including all reporting requirements. The prime contractor is responsible for the making sure that the subcontractor complies with the LWO.

8. What happens if an employer is found to be in violation of the Ordinance?

Payments due may be withheld. Also, the employer may be deemed to be in material breach of the agreement. When that happens, the City may take the following steps:

- Terminate the agreement and pursue all available contractual remedies.
- Debar the employer from doing business with the City for three (3) years or until all penalties and restitution have been fully paid, whichever occurs last.
- Bring a lawsuit against the employer for all unpaid wages and health benefit premiums and/or seek a fine of up to one hundred dollars (\$100.00) for each day the violation remains uncorrected.

9. What if a subcontractor is found to be in violation of the Ordinance?

Because the prime contractor is responsible for making sure that all its subcontractors comply with the LWO, the sanctions listed in answer #8 may be applied to the prime contractor if the subcontractor does not correct the violation(s).

10. What can an employee do if an employer is in violation of the Ordinance?

The employee can submit a complaint to the Office Contract Compliance which will investigate the complaint. Also, the employee can bring his or her own lawsuit against the employer for:

- Back pay for failing to pay the correct wages or correct health benefit premiums.
- Reinstatement and back pay for retaliation.
- Triple the amount of the back pay that is owed if the violation was found by the court to be willful.

11. Are there any exemptions available under the Ordinance?

An employer may apply for an exemption based on the following categories:

- Service agreements that are less than 3 months or \$25,000 or less.
- Agreements for the purchase of goods, property, or the leasing of property (with City as the lessee).
- Construction contracts that do not meet the definition of a service agreement.
- Employees who are required to have an occupational license in order to provide services to or for the City are exempt.
- Employers who are party to a collective bargaining agreement (CBA) that has language stating that the CBA shall supersede the LWO.
- Financial assistance recipients who meet the requirements stated in Section 10.37.1(c) of the LWO.
- Employers (contractors, subcontractors, financial assistance recipients) organized under IRS Code, Section 501(c)(3) whose chief executive officer's hourly wage rate is less than eight times the hourly wage rate of the lowest paid worker are be exempt. However, this exemption does not apply to child care workers.
- Lessees or licensees who have no more than a total of seven employees and who have annual gross revenue of less than \$454, 016 (effective July 1, 2009). The qualifying annual gross revenue is adjusted every July.
- One-person contractors, lessees, licensees or financial assistance recipients who employ no workers.
- Agreements that involve other governmental entities.

12. Who is responsible for the administration and enforcement of the Ordinance?

The Department of Public Works, Bureau of Contract Administration, Office of Contract Compliance, located at 1149 S. Broadway Street, Suite 300, Los Angeles, CA 90015. For additional information, please call (213) 847-2625, or go to the Office of Contract Compliance website at <http://bca.lacity.org>.

LIVING WAGE ORDINANCE STATUTORY EXEMPTIONS

Living Wage Ordinance (LWO) statutory exemptions are now divided into the following three categories:

1. Exemptions that do not require approval from the Department of Public Works, Bureau of Contract Administration, Office of Contract Compliance (OCC).
 2. Exemptions that do not require OCC approval but require a Contractor Certification of Exemption.
 3. Exemptions that require submission of an Application for Exemption and OCC approval of the Application.
1. **The following exemptions do not require OCC approval or any Contractor Certification**: Departments only need to indicate the exemption in the appropriate category on the LWO Departmental Determination of Coverage Form.
 - a. **Less than three months OR less than \$25,000 (LAAC 10.37.1(j))**. Service contracts or Authority for Expenditures that do not meet these thresholds are not covered by the LWO.
 - b. **Other governmental entities (LAAC 10.37.1(g))**. Agreements with other governmental entities such as Los Angeles County, the State of California, or the University of California, are not covered by the LWO. Subcontractors to these entities are also not covered by the LWO.
 - c. **Purchase of goods, property, or the leasing of property, with the City as lessee (LAAC 10.37.1(j))**. Such contracts are categorically exempt from the LWO unless they include a service component that is more than just incidental (regular and recurring services is required). Examples of such categorically exempt contracts include contracts to purchase office supplies or to lease space to be occupied by City departments.
 - d. **Construction contracts, not conforming to the definition of a service contract (LAAC 10.37.1(j))**. Such contracts are categorically exempt from the LWO. Examples include construction of buildings and infrastructure.
 - e. **City financial assistance not meeting thresholds (LAAC 10.37.1(c))**. Agreements to provide a contractor with City financial assistance (which typically mean grants or loans provided at interest rates that are lower than the Applicable Federal Rate) are categorically exempt from the LWO if they meet both of the following:
 - (1) The assistance given in a 12-month period is below \$1,000,000 AND less than \$100,000 per year.
 - (2) The assistance is not for economic development or job growth.
 - f. **Business Improvement Districts (BID) (LWO Regulation #11)**. Service agreements are categorically exempt from the LWO if the services are funded with the BID's assessment money collected by the City after the formation of the BID. Service contracts in which City money is used to hire firms to help in forming the BID remain subject to the LWO unless the contractor otherwise qualifies for an exemption.
 2. **The following exemption categories do not require OCC approval, but the contractor must still submit a Contractor Certification of Exemption from Living Wage (OCC/LW-13)**. No OCC approval is required for the exemption to be valid. However, the department must include the Contractor Certification of Exemption with the contract.
 - a. **501(c)(3) Non-profit organizations (LAAC 10.37.1(g))**: Employers (contractors, subcontractors, financial assistance recipients) organized under IRS Code Section 501(c)(3) are exempt from the LWO if the hourly wage rate of the corporation's highest paid employee is less than eight times the hourly wage rate of the corporation's lowest paid worker. However, the exemption does not extend to Child Care Workers as defined in the LWO Rules and Regulations (an employee "whose work on an agreement involves the care or supervision of children 12 years of age and under."). A copy of the IRS 501(c)(3) Exemption Letter will be required.
 - b. **One-person contractors with no employees (LAAC 10.37.1(f))**: Contractors, lessees, licensees or financial assistance recipients who employ no workers are exempt from the LWO.

LIVING WAGE ORDINANCE STATUTORY EXEMPTIONS (Continued)

- 3. The following exemption categories require submission of an application for exemption and OCC approval of the application to be valid.**
- a. Collective bargaining agreements (CBA) that supersede the LWO (LAAC 10.37.12):** Contractors whose employees are covered by a CBA that supersede the requirements of the LWO are not subject to the LWO. A copy of the CBA with the superseding language or a letter from the union indicating that the union has agreed to allow the CBA to supersede the LWO will be required to be submitted. Example: Labor agreement between parking contractor and a labor union with language that wages and benefits in the CBA shall supersede the LWO. Contractors must use the LWO Application for Non-Coverage or Exemption form (Form OCC/LW-10) and submit a copy of the CBA or a letter from the union.
 - b. Occupational license (LAAC 10.37.1(f)):** Employees required to possess an occupational license in order to provide the services under the City agreement are not subject to the LWO. However, only the individual employees who are required to possess an occupational license are exempt. Employees who work on the City contract and are not required to possess an occupational license remain subject to the LWO. Example: Under California Labor Code Sections 7375 – 7380, a person must be licensed by the State of California in order to inspect and certify cranes and derricks used in lifting services. Contractors must use the LWO Application for Non-Coverage or Exemption form (Form OCC/LW-10) and submit a listing of the employees who possess occupational licenses and a copy of the licenses.
 - c. Small business exemptions for Public Lessees/Licensees (LAAC 10.37.1(i)):** Small business that lease property from the City may apply for OCC approval for LWO exemption if the lessee or licensee: (1) employs no more than a total of seven employees; and (2) has annual gross revenues of less than \$454,016 (adjusted July 1, 2009). This applies only to lessees with lease agreements executed after February 24, 2001, and to amendments executed after February 24, 2001 that add monies or extend term. Use the Application for “Small Business” Exemption (Form OCC/LW-20) and submit the application with the documents requested on that form.
 - d. City financial assistance agreements that exceed the LWO monetary thresholds may apply for one of the exemptions below.** Applicants and departments should refer to Regulation #3(c) for the requirements and the documents that must be submitted with the LWO Application for Non-Coverage or Exemption (OCC/LWO-10).
 - (1) The City financial assistance recipient (CFAR) is in its first year of operation (LAAC 10.37.1(c)).
 - (2) The CFAR employs fewer than five employees (LAAC 10.37.1(c)).
 - (3) The CFAR would face undue hardship because it employs the long-term unemployed or provides trainee positions to prepare employees for permanent positions (LAAC 10.37.1(c)). REQUIRES COUNCIL APPROVAL.

LWO –DEPARTMENTAL EXEMPTION APPLICATION

EXEMPTIONS THAT REQUIRE AWARDING DEPARTMENT APPROVAL

This application for exemption must be submitted along with your bid or proposal to the AWARDING DEPARTMENT. INCOMPLETE SUBMISSIONS WILL BE RETURNED.

Los Angeles Administrative Code 10.37, the Living Wage Ordinance (LWO), presumes all City contractors (including service contractors, subcontractors, financial assistance recipients, lessees, licensees, sublessees and sublicensees) are subject to the LWO unless an exemption applies.

TO BE FILLED OUT BY THE CONTRACTOR:
1. Company Name: _____ Phone Number: _____
2. Company Address: _____
3. Are you a Subcontractor? <input type="checkbox"/> Yes <input type="checkbox"/> No If YES, state the name of your Prime Contractor: _____
4. Type of Service Provided: _____

EXEMPTION INFORMATION:
CHECK OFF ONE BOX BELOW THAT BEST DESCRIBES THE TYPE OF EXEMPTION YOU ARE APPLYING FOR AND ATTACH THE SUPPORTING DOCUMENTATION LISTED ON THE RIGHT:

EXEMPTION	SUPPORTING DOCUMENTATION REQUIRED
<input type="checkbox"/> 501(c)(3) Non-Profit Organizations: <ul style="list-style-type: none"> ▪ A corporation organized under 501(c)(3) of the IRS Code qualifies for an exemption from the LWO if the highest paid employee makes less than eight times the hourly wage of the lowest paid employee. ▪ The exemption is valid for all employees except Child Care Workers. ▪ Therefore, even if a 501(c)(3) organization meets the salary test, Child Care Workers performing work on the City agreement must still be provided with the LWO required wage and time off benefits. ▪ Under the LWO's Rules and Regulations, a Child Care Worker is an employee "whose work on an agreement involves the care or supervision of children 12 years of age and under." ▪ This is read broadly so that the term would include, for example, tutors working with children 12 or under. 	<ol style="list-style-type: none"> 1. ATTACH a copy of your 501(c)(3) letter from the IRS. 2. ANSWER the following questions: <ol style="list-style-type: none"> A. STATE the hourly wage of HIGHEST paid employee in the organization: \$ _____ B. STATE the hourly wage of LOWEST paid employee in the organization: \$ _____ C. MULTIPLY B by 8: \$ _____ 3. Based on Question 2 above, is A less than C? <input type="checkbox"/> YES <input type="checkbox"/> NO If NO, your company is NOT eligible for an exemption. If YES, sign and submit this application for final approval. 4. Will there be any Child Care Workers (as defined by the LWO Regulations) working on this Agreement? <input type="checkbox"/> YES <input type="checkbox"/> NO 5. Fill & Submit LW-18 Subcontractor Information Form.
<input type="checkbox"/> One-Person Contractors: Contractors that have no employees are exempt from the LWO. If you have employees in the future, you must comply with the Ordinance.	Fill and Submit the LW-18 Form.

I declare under penalty of perjury under the laws of the State of California that: (1) I am authorized to bind the entity listed above; (2) the information provided on this form is true and correct to the best of my knowledge; and (3) the entity qualifies for exemption from the LWO on the basis indicated above. By signing below, I further agree that **should the entity listed above cease to qualify** for an exemption because of a change in salary structure, non-profit status, the hiring of employees, or any other reason, **the entity will notify the Awarding Department and the OCC of such change and comply with the LWO's wage and time off requirements.**

Print Name of Person Completing This Form	Signature of Person Completing This Form
Title	Date
Phone #	

ANY APPROVAL OF THIS APPLICATION EXEMPTS ONLY THE LISTED CONTRACTOR FROM THE LWO DURING THE PERFORMANCE OF THIS CONTRACT. A SUBCONTRACTOR PERFORMING WORK ON THIS CONTRACT IS NOT EXEMPT UNLESS THE OFFICE OF CONTRACT COMPLIANCE HAS APPROVED A SEPARATE EXEMPTION FOR THE INDIVIDUAL SUBCONTRACTOR.

AWARDING DEPARTMENT USE ONLY:
Dept: _____ Dept Contact: _____ Contact Phone: _____ Contract #: _____
Approved / Not Approved – Reason: _____
By Analyst: _____ Date: _____

LWO – OCC NON-COVERAGE/EXEMPTION APPLICATION

OCC DETERMINATION/APPROVAL REQUIRED

RFP EXHIBIT D

This application for non-coverage/exemption must be submitted by the Contractor along with its bid or proposal to the AWARDING DEPARTMENT. Awarding Departments may also apply for an exemption for OCC approval. **INCOMPLETE SUBMISSIONS WILL BE RETURNED.**

Los Angeles Administrative Code 10.37, the Living Wage Ordinance (LWO), presumes all City contractors (including service contractors, subcontractors, financial assistance recipients, lessees, licensees, sublessees and sublicensees) are subject to the LWO unless an exemption applies.

CONTRACTOR INFORMATION:

1. Company Name: _____ Phone Number: _____
2. Company Address: _____
3. Are you a Subcontractor? Yes No If YES, state the name of your Prime Contractor:

4. Type of Service Provided: _____

NON-COVERAGE INFORMATION:

TO BE REQUESTED BY AWARDING DEPARTMENTS OR CONTRACTORS

REQUEST FOR NON-COVERAGE DETERMINATION	SUPPORTING DOCUMENTATION REQUIRED
<input type="checkbox"/> Per Section 10.37.13 of the LWO, contractors may request a determination of non-coverage on any basis allowed by this article, including, but not limited to: non-coverage, for failure to satisfy definition of "City financial assistance recipient", "public lease/license", or "service contract".	A <i>detailed</i> memorandum explaining the basis of the request, which may include, but is not limited to: the terms of a city financial assistance agreement, purpose of the contract, location, and work performed. OCC may request further information to issue a determination.

EXEMPTION INFORMATION:

CHECK OFF ONE BOX BELOW THAT BEST DESCRIBES THE TYPE OF EXEMPTION YOU ARE APPLYING FOR AND ATTACH THE SUPPORTING DOCUMENTATION LISTED ON THE RIGHT:

TO BE REQUESTED BY AWARDING DEPARTMENTS ONLY

EXEMPTION	SUPPORTING DOCUMENTATION REQUIRED
<input type="checkbox"/> Grant Funded Services, provided that the grant funding agency indicates in writing that the provisions of the Ordinances should not apply.	Provide a copy of grant-funding agency's determination to the OCC.

TO BE REQUESTED BY CONTRACTORS ONLY

EXEMPTION	SUPPORTING DOCUMENTATION REQUIRED
<input type="checkbox"/> Collective bargaining agreement with supersession language - (LAAC 10.37.12): Contractors who are party to a collective bargaining agreement (CBA) which contains specific language indicating that the CBA will supersede the LWO may receive an exemption as to the employees covered under the CBA.	A copy of the CBA with the superseding language clearly marked OR A letter from the union stating that the union has agreed to allow the CBA to supersede the LWO.
<input type="checkbox"/> Occupational license required - (LAAC 10.37.1(f)): Only the individual employees who are required to possess an Occupational license to provide services to or for the City are exempt.	A listing of the employees required to possess occupational licenses to perform services to or for the City AND Copies of each of these employees' occupational licenses.

By signing, the contractor certifies under penalty of perjury under the laws of the State of California that the information submitted in support of this application is true and correct to the best of the contractor's knowledge.

Print Name of Person (Contractor) Completing This Form

Signature of Person (Contractor) Completing This Form

Title

Phone #

Date

ANY DETERMINATION/APPROVAL IS APPLICABLE ONLY TO THE LISTED CONTRACTOR FROM THE LWO DURING THE PERFORMANCE OF THIS CONTRACT. A SUBCONTRACTOR PERFORMING WORK ON THIS CONTRACT IS NOT EXEMPT UNLESS THE OFFICE OF CONTRACT COMPLIANCE HAS APPROVED A SEPARATE APPLICATION FOR THE INDIVIDUAL SUBCONTRACTOR.

AWARDING DEPARTMENT USE ONLY:

Dept: _____ Dept Contact: _____ Contact Phone: _____ Contract #: _____

OCC USE ONLY:

Approved / Not Approved – Reason: _____

By OCC Analyst: _____

Date: _____

CITY OF LOS ANGELES
SERVICE CONTRACTOR WORKER RETENTION ORDINANCE
(Los Angeles Administrative Code Section 10.36 et seq.)

1. What is the Service Contractor Worker Retention Ordinance?

The Service Contractor Worker Retention Ordinance (SCWRO), effective May, 1996, requires a successor contractor and its subcontractors to retain for a 90-day period certain employees who worked for the terminated contractor or its subcontractors for at least 12 months. (See also Question #7 regarding which employees are covered.)

2. What is a successor contractor?

A successor contractor is one who has been awarded an agreement to provide services to or for the City that are similar to those that were provided under a recently terminated agreement.

3. What types of agreements are covered by the Ordinance?

The SCWRO covers the following types of agreements:

- For services in an amount over \$25,000.00 and for at least three months.
- In which the primary purpose is to provide services to or for the City (including leases and licenses).
- In which the City provides financial assistance for the purpose of promoting economic development or job growth.

4. What does the Ordinance require a terminated contractor to do?

The SCWRO requires the terminated contractor to provide the awarding authority with the names, addresses, dates of hire, hourly wage, and job classes of each employee who worked on the City agreement for that terminated contractor or its subcontractor. The awarding authority will provide the information to the successor contractor.

5. What does the Ordinance require a successor contractor to do?

The Ordinance requires the successor contractor to:

- Offer employment and retain for a 90-day period the employees who worked for at least 12 months for the terminated contractor or its subcontractors.
- Not discharge the employees retained under the SCWRO without cause during the 90-day period.
- Perform a written performance evaluation of each employee retained under the SCWRO at the end of the 90-day period.

6. Do the employees retained under the Ordinance receive any additional protection?

Employees retained under the SCWRO are employed under the terms and conditions of the successor contractor or as required by law. However, if the agreement the employees are working under is subject to Living Wage Ordinance (LWO), the employees must be paid the wage rate and be provided the benefits required by LWO.

7. Does the successor contractor have to retain all the prior contractor's employees?

The SCWRO covers only employees who meet all of the following requirements:

- Earn less than \$15.00 per hour.
- Primary job is in the City working on or under the City agreement.
- Worked for the terminated contractor or its subcontractor for the preceding 12 months or longer.
- Not a managerial, supervisory, or confidential employee; or an employee required to possess an occupational license.

8. What if the successor contractor determines that fewer employees are required to provide the services than were required by the prior contractor?

The names of the affected employees will be placed in order by seniority within each job classification. The successor contractor is required to retain employees based on seniority. The names of employees not retained will be placed on a preferential hiring list from which the successor contractor must use for subsequent hires.

9. What happens if an employee is discharged in violation of the Ordinance?

The employee may bring a lawsuit against the successor contractor. The employee can also submit a complaint to the Department of Public Works, Bureau of Contract Administration, Office of Contract Compliance which will investigate the complaint.

10. What if a contractor is found to be in violation of the Ordinance?

The City may terminate the agreement or pursue other legal remedies.

11. Who is responsible for administering and enforcing the Ordinance?

The Department of Public Works, Bureau of Contract Administration, Office of Contract Compliance, located at 1149 S. Broadway St., Suite 300, Los Angeles, CA 90015. For additional information, please call (213) 847-2625, or go to the Office of Contract Compliance web site at <http://bca.lacity.org>.

BUSINESS INCLUSION PROGRAM

SECTION G**BUSINESS INCLUSION PROGRAM**

Established by Mayor's Executive Directive No. 14, this program requires all respondents to Requests for Bids (RFB), Requests for Proposals (RFPs), and Requests for Qualifications (RFQs) to perform subcontractor outreach to all available MBE/WBE/SBE/EBE/DVBE/OBE firms which could perform a portion of the scope of work required in the respective RFB, RFP, or RFQ. As proof of the respondent's outreach efforts, the respondent is required to perform the Business Inclusion Program Outreach on the Business Assistance Virtual Network (BAVN), www.labavn.org

INSTRUCTIONS:

- a. All proposers must perform and submit the Business Inclusion Program Outreach as described in the following instructions.

**CITY OF LOS ANGELES BUSINESS INCLUSION PROGRAM (BIP)
FOR A REQUEST FOR PROPOSAL (RFP)**

Performance of a BIP outreach to Minority Business Enterprises (MBE), Women Business Enterprises (WBE), Small Business Enterprises (SBE), Emerging Business Enterprises (EBE), Disabled Veteran Business Enterprises (DVBE), and Other Business Enterprises (OBE) subconsultants must be completed on the Business Assistance Virtual Network (BAVN), www.labavn.org.

All BIP outreach documentation must be submitted on the BAVN by 4:30 p.m. on the first calendar day following the day of the RFP response submittal deadline.

The Recreation and Parks anticipated levels of

MBE Participation:	<u>See RFP</u>
WBE Participation:	<u>See RFP</u>
SBE Participation:	<u>See RFP</u>
EBE Participation:	<u>See RFP</u>
DVBE Participation:	<u>See RFP</u>

NOTE: BIP outreach information and/or assistance may be obtained through the Contract Coordinator listed in the RFP.

**CITY OF LOS ANGELES' POLICY
BUSINESS INCLUSION PROGRAM (BIP) FOR A REQUEST FOR PROPOSAL (RFP)**

SUMMARY

This policy sets forth the City of Los Angeles' rules and procedures to be followed by respondents on advertised personal services contracts in regards to the City's BIP outreach requirements. In general, this policy provides that respondents for contracts must demonstrate compliance with the indicators relating to an active outreach program to obtain participation by MBEs, WBEs, SBEs, EBEs, DVBEs, and OBEs. Failure to demonstrate an outreach on the BAVN to comply with the indicators will render the bid non-responsive.

A. GENERAL

This policy statement explains how the City's BIP will be administered within the Awarding Authority for personal services contracts. The Awarding Authority is committed to ensuring full and equitable participation by minority, women, small, emerging, disabled veteran, and other businesses in the provision of all goods and services to the Department on a contractual basis. The BIP is set forth in this policy Statement. Respondents to the Awarding Authority shall be fully informed concerning the requirements of this Program. **Failure to comply with the City's BIP outreach requirements will render the response non-responsive and result in its rejection.**

B. DEFINITIONS

1. Minority or Women Business Enterprise (MBE or WBE): For the purpose of this program, Minority or Women Business Enterprise shall mean a business enterprise that meets both of the following criteria:
 - a. A business that is at least 51 percent owned by one or more minority persons or women, in the case of any business whose stock is publicly held, at least 51 percent of the stock is owned by one or more minority persons or women; and
 - b. A business whose management and daily business operations are controlled by one or more minority persons or women.
2. Small Business Enterprise (SBE): For the purpose of this program, Small Business Enterprise shall mean a business enterprise that meets the following criteria:
 - a. A business (personal or professional services, manufacturer, supplier, vendor) whose three (3) year average annual gross revenues does not exceed \$7 million.
 - b. A business (construction contractors) whose three (3) year average annual gross revenues does not exceed \$14 million.
3. Emerging Business Enterprise (EBE): For the purpose of this program, Emerging Business Enterprise shall mean a business enterprise whose three (3) year average annual gross revenues does not exceed \$3.5 million.

4. Disabled Veteran Business Enterprise (DVBE): For the purpose of this program, Disabled Veteran Business Enterprise shall mean a business enterprise that meets the following criteria:
 - a. A business that is at least 51 percent owned by one or more disabled veterans.
 - b. A business whose daily business operations must be managed and controlled by one or more disabled veterans.
5. Other Business Enterprise (OBE): For the purpose of this program, Other Business Enterprise shall mean any business enterprise which either does not otherwise qualify or has not been certified as a Minority, Women, Small, Emerging, and/or Disabled Veteran Business Enterprise.
6. Minority person: For the purpose of this program, the term "Minority person" shall mean African Americans; Hispanic Americans; Native Americans (including American Indians, Eskimos, Aleuts, and Native Hawaiians); Asian-Pacific Americans (including persons whose origins are from Japan, China, Taiwan, Korea, Vietnam, Laos, Cambodia, the Philippines, Samoa, Guam, the United States Trust Territories of the Pacific, Northern Marianas); and Subcontinent Asian Americans (including persons whose origins are from India, Pakistan and Bangladesh).
7. Disabled Veteran: For the purpose of this program, the term "Disabled Veteran" shall mean a veteran of the U.S. military, naval, or air service; the veteran must have a service-connected disability of at least 10% or more; and the veteran must reside in California.
8. Certification must be current **on the date the Awarding Authority awards a contract for the project** if credit is to be allowed towards the anticipated levels of MBE, WBE, SBE, EBE, and/or DVBE participation on this contract.
 - a. Certification as a Minority or Women Business Enterprise: an MBE/WBE must be certified by 1) City of Los Angeles, Bureau of Contract Administration; 2) State of California Department of Transportation (CalTrans); 3) Los Angeles County Metropolitan Transportation Authority (Metro); 4) Southern California Minority Business Development Council (SCMBDC) for MBE certifications only; or 5) any certifying agency that is a part of the State of California Unified Certification Program (CUCP) so long as the certification meets all of the City of Los Angeles' MBE/WBE certification requirements.

Applications for certification and directories of MBE/WBE certified firms are available at the following locations:

- 1) City of Los Angeles
 Bureau of Contract Administration, Office of Contract Compliance
 1149 S. Broadway, Suite 300, Los Angeles, CA 90015
 Telephone: (213) 847-2684 FAX: (213) 847-2777
 Internet address: <http://www.lacity.org/BCA>

- 2) CalTrans
 Caltrans Division of Procurement and Contracts/Material and Distribution Branch/Publication Unit
 1900 Royal Oaks Drive, Sacramento, CA 95815
 To order a directory, call (916) 445-3520
 Internet address: <http://www.dot.ca.gov/hq/bep/>
- 3) Los Angeles County Metropolitan Transportation Authority
 Equal Opportunity Department
 1 Gateway Plaza, Los Angeles, CA 90012
 Telephone: (213) 922-2600 FAX: (213) 922-7660
 Internet address: <http://www.mta.net>
- 4) Southern California Minority Business Development Council, Inc. (for a fee)
 800 W. 6th Street, Suite 850, Los Angeles, CA 90017
 Telephone: (213) 689-6960 Fax: (213) 689-1707
 Internet address: <http://www.scmdbc.org>
- b. Certification as a Small or Emerging Business Enterprise: An SBE or EBE firm must be certified by either: 1) City of Los Angeles, Bureau of Contract Administration; or 2) State of California, Office of Small Business & Disabled Veterans Business Enterprise Services so long as the certification meets all of the City of Los Angeles' SBE or EBE certification criteria. Note: The State of California does not offer EBE certifications. For the purposes of this program, the State's Microbusiness certification will be considered synonymous with the City's EBE certification.
- c. Certification as a Disabled Veteran Business Enterprise: A DVBE must be certified by State of California, Office of Small Business & Disabled Veterans Business Enterprise Services.
9. Business Inclusion Program Outreach Documentation: The respondent must take affirmative steps prior to submission of their RFP response to ensure that a maximum effort is made to recruit subconsultants. Minority, women, small, emerging, disabled veteran owned and controlled businesses must be considered along with other business enterprises whenever possible as sources of subconsulting services. Affirmative steps for BIP Outreach Documentation are outlined in Paragraph C herein. The BIP Outreach Documentation must be submitted as described in Paragraph C herein. Failure to submit the BIP Outreach Documentation will render the response non-responsive.
10. Subcontract: For the purpose of this program, the term "Subcontract" denotes an agreement between the prime Consultant and an individual, firm or corporation for the performance of a particular portion(s) of the work which the prime Consultant has obligated itself.
11. Subconsultant: An individual, firm, or corporation having a direct contract with the consultant for the performance of a part of the work which is proposed to be constructed or done under the contract or permit, including the furnishing of all labor, materials, or

equipment. For the purposes of this Program, a subconsultant may also be referred to as a subcontractor.

12. Vendor and/or supplier: A firm that owns, operates or maintains a store, warehouse, or other establishment in which the materials or supplies required for the performance of the contract are bought, kept in stock, and regularly sold to the public in the usual course of business. The firm must engage in, as its principal business, and its own name, the purchase and sale of the products in question. A vendor and/or supplier of bulk items such as steel, cement, stone and petroleum products need not keep such products in stock, if it owns or operates distribution equipment.
13. Manufacturer: A firm that operates or maintains a factory or establishment that produces on the premises the materials or supplies obtained by the contractor.
14. Broker: A firm that charges for providing a bona fide service, such as professional, technical, consultant or managerial services and assistance in the procurement of essential personnel, facilities, equipment, insurance or bonds, materials or supplies required for performance of the contract. The fee or commission is to be reasonable and not excessive as compared with fees customarily allowed for similar services.
15. Participation Recognition: This applies to recognition as an MBE, WBE, SBE, EBE, DVBE.
 - a. All listed MBE, WBE, SBE, EBE, and/or DVBE firms must be certified as defined under Paragraph B, Definitions, Item 4, on the date the Awarding Authority awards a contract for the project before credit may be allowed toward the respective MBE, WBE, SBE, EBE, and/or DVBE pledged participation level.
 - b. Work performed by a MBE, WBE, SBE, EBE, and/or DVBE prime consultant will not be a consideration when determining a prime consultant's BIP Outreach. The prime consultant will be required to make a BIP Outreach to obtain reasonable anticipated MBE, WBE, SBE, EBE, and/or DVBE participation levels through subconsulting or materials and supplies acquisition.
 - c. Recognition for materials and/or supplies is limited to 60 percent of the amount to be paid to the vendor for such materials/supplies in computing the pledged levels of MBE, WBE, SBE, EBE, and/or DVBE participation, unless the vendor manufactures or substantially alters the materials/supplies.
 - d. MBE, WBE, SBE, EBE, and/or DVBE credit for brokers required for performance of the contract is limited to the reasonable fee or commission charged, as not considered excessive, as compared with fees customarily allowed for similar services.
 - e. A firm which qualifies as both a MBE and a WBE will be credited as either MBE participation or as WBE participation, but will not be credited for both. However, a MBE and/or WBE firm may also receive SBE, EBE and/or DVBE credit if so qualified.

- f. A listed MBE, WBE, SBE, EBE, and/or DVBE firm must be potentially available to perform a commercially useful function, i.e., must be potentially responsible for the execution of a distinct element of the work and potentially available to carry out its responsibility by performing, managing and supervising the work.
- g. MBE/WBE credit shall not be given to a Joint Venture partner listed as a subconsultant by a Joint Venture respondent.
- h. A SBE, EBE, DVBE prime consultant shall receive pledged participation credit for the work performed by its own workforce.

C. **BIP OUTREACH DOCUMENTATION**

It is the policy of the City of Los Angeles to provide Minority Business Enterprises (MBEs), Women Business Enterprises (WBEs), Small Business Enterprises (SBEs), Emerging Business Enterprises (EBEs), Disabled Veteran Business Enterprises (DVBEs), and all Other Business Enterprises (OBEs) an equal opportunity to participate in the performance of City contracts. In order to maximize this participation while minimizing the administrative impact on city staff and RFP respondents alike, the Mayor's Office has developed a Business Inclusion Program (BIP). The BIP requires City departments to set anticipated participation levels based on the opportunities presented in their advertised contracts and department's achievement of its annual goals. A respondent's BIP Outreach to MBEs, WBEs, SBEs, EBEs, DVBEs, and OBEs shall be determined by their compliance with the following BIP Outreach process which will be performed on the City's Business Assistance Virtual Network (BAVN). The BAVN can be accessed by going to the City's Webpage (<http://www.lacity.org>) and linking onto "Bids, RFPs & Grants" or directly at www.labavn.org. Failure to meet the anticipated MBE, WBE, SBE, EBE, and/or DVBE participation levels will not by itself be the basis for disqualification or determination of noncompliance with this policy. **However, failure to comply with the BIP Outreach documentation requirements as described in this section will render the RFP response non-responsive and will result in its rejection.** *Compliance with the BIP Outreach requirements is required even if the proposer has achieved the anticipated MBE, WBE, SBE, EBE, and DVBE participation levels.* Adequacy of a bidder's BIP Outreach will be determined by the Awarding Authority after consideration of the indicators of BIP Outreach as set forth below.

Any technical difficulties while utilizing the BAVN should be reported immediately using the following steps:

1. Email BAVN Support at support@labavn.org.
2. Email the Contract Coordinator listed in the RFP.
3. If you are not contacted within 15 minutes during normal City working hours (7:00 a.m. to 4:30 p.m. Monday-Friday), call the Contract Coordinator listed in the RFP.

If the above procedures are not followed as stipulated, incomplete outreach and/or incomplete documentation may not be accepted.

Each indicator (2-6) is evaluated on a pass/fail basis. All indicators (2-6) must be passed to be deemed responsive. Only BIP Outreach documentation submitted under the bidders name will be evaluated. Therefore submission by a third party will result in the bidder being deemed non-responsive.

1	LEVEL OF ANTICIPATED MBE, WBE, SBE, EBE, and DVBE PARTICIPATION
---	--

The proposer has performed a BIP Outreach in an attempt to obtain potential subconsultant participation by MBEs, WBEs, SBEs, EBEs, DVBEs and OBEs which could be expected by the Board to produce a reasonable level of participation by interested business enterprises, including the MBE, WBE, SBE, EBE and DVBE anticipated percentages set forth in the RFP and to have the proposer meet the subconsulting expectations for the project.

2	ATTENDED PRE-BID MEETING
---	---------------------------------

The proposer attended the pre-proposal meeting scheduled by the Project Manager to inform all proposers of the requirements for the project for which the contract will be awarded. This requirement may be waived if the proposer certifies it is informed as to those project requirements and has participated in a City-sponsored or City-approved matchmaking event in the prior 12 months.

Required Documentation: An employee of the proposer's company must attend the pre-submittal meeting scheduled for this project. Credit may not be given if the employee arrives late or fails to sign the pre-submittal meeting attendance roster. This requirement will be waived if the proposer both certifies in writing that it is informed as to the BIP Outreach requirements for the project and has participated in a City-sponsored or City-approved matchmaking event in the prior 12 months as is evidenced by the event attendance documents.

Note: If the RFP states that the pre-submittal meeting is mandatory, then attendance at the pre-submittal meeting is the only way to pass this indicator.

3	SUFFICIENT WORK IDENTIFIED FOR SUBCONSULTANTS
---	--

The proposer has identified the minimum number, as determined by the Awarding Authority, of specific items of work that will be performed by subconsultants. This will ensure an opportunity for subconsultant participation among MBEs, WBEs, SBEs, EBEs, DVBEs, and OBEs.

Required Documentation: Outreach via e-mail in the selected potential work items. This outreach must be performed using the BAVN's BIP Outreach system. The outreach must be to potential MBE, WBE, SBE, EBE, DVBE, and OBE subconsultants who are currently registered on the BAVN. Failure of the proposer to outreach in all of the potential work items selected by the City as potential subconsulting work items may result in the RFP response being deemed non-responsive.

Note: City staff will access the BAVN and verify compliance with this indicator after the RFP submission deadline.

4	WRITTEN NOTICES TO SUBCONSULTANTS
---	--

All notifications must be provided utilizing BAVN, and made not less than **fifteen (15) calendar days** prior to the date the Prime Bid/Proposal is required to be submitted. In all instances, proposers must document that invitations for subcontracting bids were sent to available MBEs, WBEs, SBEs, EBEs, DVBEs and OBEs for each item of work to be performed.

Required Documentation: E-mail notification in each of the selected potential work items to potentially available MBEs, WBEs, SBEs, EBEs, DVBEs and OBEs for each anticipated work item to be performed. The notification must be performed using the BAVN's BIP Outreach system. The notification must be to potential subcontractants currently registered on the BAVN. If the proposer is aware of a potential subcontractant that is not currently registered on the BAVN, it is the proposer's responsibility to encourage the potential subcontractant to become registered so that the proposer can include them as part of their outreach. Letters must contain areas of work anticipated to be subconsulted, City of Los Angeles project name, name of the proposer, and contact person's name, address, and telephone number. Proposers are required to send notifications to a sufficient number of firms comprised of MBEs, WBEs, SBEs, EBEs, DVBEs and OBEs in each potential work item chosen, as determined by the City. What is considered sufficient will be determined by the total number of potential subcontractants in each specific work item.

The City will determine each work area by the North American Industry Classification System (NAICS) code. The following table shows the sufficient number of MBE, WBE, SBE, EBE, DVBE and OBE subcontractors that need to be notified for each work area.

# of Subcontractors in NAICS Code	% Prime Must Notify	Number Prime Must Notify
1-10	100%	1-10
11-20	80%	9-16
21-50	60%	13-30
51-100	40%	21-40
101-200	25%	26-50
>200	10%	20+

A proposer's failure to utilize this notification function will result in their RFP response being deemed non-responsive.

Note: Proposers will not be able to utilize the BAVN's BIP Outreach notification function if there are less than fifteen (15) calendar days prior to the RFP response submittal deadline. In utilizing the BAVN's notification function, proposers will receive a message if they have failed to outreach to a sufficient number of firms when they go to view their summary sheet. Proposers will be given an opportunity to include their own customized statements when utilizing the notification function. However, the City will take into consideration the wording and may deem a proposer non-responsive if the wording is perceived to seriously limit potential subcontractant

responses. City staff will access the BAVN and verify compliance with this indicator after the RFP submission deadline. Proposers are encouraged to print their BIP Outreach summary sheet prior to logging out as documented proof of their progress.

5	PLANS, SPECIFICATIONS AND REQUIREMENTS
---	---

The proposer provided interested potential subconsultants with information about the availability of plans, specifications, and requirements for the selected subconsulting work.

Required Documentation: Include in Indicator 4, information detailing how, where and when the proposer will make the required information available to interested potential subconsultants. The notification must be performed using the BAVN's BIP Outreach system.

Note: For purposes of RFPs, making a copy of the RFP available to potential subconsultants will meet this requirement. At the time a proposer utilizes the BAVN's BIP Outreach notification function, the required information will automatically be included in the notification. Proposers will not be able to utilize the BAVN's BIP Outreach notification function if there are less than fifteen (15) calendar days prior to the RFP response submittal deadline. City staff will access the BAVN and verify compliance with this indicator after the RFP submission deadline.

6	NEGOTIATED IN GOOD FAITH
---	---------------------------------

The proposer has responded to every unsolicited offer sent by a Registered Subcontractor using BAVN and has evaluated in good faith bids or proposals submitted by interested MBEs, WBEs, SBEs, EBEs, DVBEs, and OBEs. Proposers must not unjustifiably reject as unsatisfactory a bid or proposal offered by a Registered Subcontractor, as determined by the Awarding Authority. The proposer must submit a list of all subcontractors for each item of work, including dollar amounts of potential work for MBEs, WBEs, SBEs, EBEs, DVBEs, and OBEs, and a copy of any and all bids or proposals received. This list must include an explanation of the evaluation that led to the bid or proposal being rejected and the explanation must have been communicated to the subcontractor using BAVN.

Required Documentation:

- a) Schedule A MBE/WBE/SBE/EBE/DVBE/OBE Subconsultants Information Form;
- b) An online Summary Sheet organized by work area, listing the following:
 - 1) The responses and/or bids received;
 - 2) The name of the subconsultant who submitted the bid/quote;
 - 3) A brief reason given for selection/non-selection as a subconsultant;
- c) Copies of all potential MBE/WBE/SBE/EBE/DVBE/OBE bids or quotes received must be submitted prior to award of a contract by the City;

The reasons for selection/non-selection should be included in the notes section of the online Summary Sheet. If the proposer elects to perform a listed work area with its own forces, they must include a bid/quote for comparison purposes and an explanation must be provided and included on the summary sheet. **All bids/quotes received, regardless of whether or not the proposer outreached to the subconsultant, must be submitted and included on the on-line Summary**

Sheet. To that extent, the City expects the proposer to submit a bid from each subconsultant listed on the online Summary Sheet, including those listed on the proposer's Schedule A. **All potential subcontractors with whom the bidder has had contact outside of the BAVN must be documented on the online Summary Sheet.**

The summary sheet must be performed using the BAVN's BIP Outreach system and must be submitted by 4:30 p.m. on the first calendar day following the day of the RFP response submittal deadline. If a bid/quote is submitted by a firm that is not registered with the BAVN, the proposer is required to add that firm to their summary sheet. A proposer's failure to utilize the BAVN's summary sheet function will result in their RFP response being deemed non-responsive.

Note: Staff will request copies of all of the bids/quotes received as part of the BIP Outreach evaluation process. Proposers must have a bid/quote from each potential subconsultant listed on their Schedule A prior to submission of the Schedule A. The submission of the Schedule A is outlined in G herein. Proposers are encouraged to submit all of their bids/quotes with their RFP response submittal. Proposers will not be able to edit their summary sheet on the BAVN's BIP Outreach summary sheet function after 4:30 p.m. on the first calendar day following the day of the RFP response submittal deadline. City staff will access the BAVN and verify compliance with the summary sheet provision of this indicator after the RFP submission deadline. Proposers are required to have each of the subconsultants on their Schedule A registered on the BAVN prior to being awarded the contract.

7

BOND, LINES OF CREDIT, AND INSURANCE ASSISTANCE

Each notification by the proposer shall also include an offer of assistance to interested potential MBEs, WBEs, SBEs, EBEs, DVBEs, and OBEs in obtaining bonds, lines of credit, and insurance required by the Awarding Authority or proposer.

Required Documentation: Include in Indicator 4, information about the proposer's efforts to assist with bonds, lines of credit and insurance. The notification must be performed using the BAVN's BIP Outreach system.

Note: At the time a proposer utilizes the BAVN's BIP Outreach notification function, the required information will automatically be included in the notification. Proposers will not be able to utilize the BAVN's BIP Outreach notification function if there are less than fifteen (15) calendar days prior to the RFP response submittal deadline. Proposers will be given an opportunity to include their own customized statements when utilizing the notification function. However, the City will take into consideration the wording and may deem a proposer non-responsive if the wording seriously limits potential subconsultant responses or is deemed contrary to the intent of this indicator. City staff will access the BAVN and verify compliance with this indicator after the RFP submission deadline.

The proposer shall submit completed BIP Outreach documentation either via the BAVN's BIP Outreach system or prior to award, as specified for each indicator. The Awarding Authority in its review of the BIP Outreach documentation may request additional information to validate and/or clarify that the BIP Outreach submission was adequate. Any additional information submitted after the response due date and time will be treated at a higher level of scrutiny and may require

third Party documentation in order to substantiate its authenticity. Such information shall be submitted promptly upon request by the Awarding Authority.

D. AWARD OF CONTRACT

The Awarding Authority reserves the right to reject any and all RFP responses. The award of a contract will be to the responsive, responsible proposer whose proposal complies with all requirements prescribed herein. This includes compliance with the required Business Inclusion Program Outreach. A positive and adequate demonstration to the satisfaction of the Awarding Authority that a BIP Outreach to include MBE/WBE/SBE/EBE/DVBE/OBE subconsultants' participation was made is a condition for eligibility for award of the contract.

In the event that the Awarding Authority considers awarding away from a proposer because of the proposer's failure to supply adequate BIP Outreach documentation, the Awarding Authority shall afford the proposer an opportunity to present further evidence to the Awarding Authority prior to a public hearing of the proposer's BIP Outreach evaluation.

E. SUBCONSULTANT SUBSTITUTION

In addition to the requirements set forth in the provisions pertaining to the listing of subconsultants, the following shall apply for the purpose of this program:

1. Substitution During Contract Duration: The contract award requires that the level of all subconsultant participation shall be maintained throughout the duration of the contract. To this extent, any unapproved reduction in the listed subcontract amount will be considered an unauthorized substitution.
 - a. The Consultant shall request approval of the Awarding Authority for all substitutions of bid-listed (Schedule A) subconsultants.
 - b. The request shall be in writing and submitted to the designated Project Manager for the Awarding Authority. The request shall give the reason for the substitution, the name of the subconsultant and the name of the replacement.
2. MBE/WBE/SBE/EBE/DVBE/OBE Subconsultant Substitution: The Awarding Authority requires that whenever the Consultant seeks to substitute a bid-listed (Schedule A) subconsultant, the Consultant must make a BIP Outreach to replace the subconsultant.
 - a. The Consultant shall contact some of each of the following: certified MBE, certified WBE, certified SBE, certified EBE, certified DVBE, and OBE sub-bid prospects from each trade for which sub-bid/subconsulting work is available and document the following for submittal:
 - 1) Name of company contacted; contact person and telephone number; date and time of contact.
 - 2) Response for each item of work which was solicited, including dollar amounts.

- 3) Reason for selection or rejection of sub-bid prospect.
 - 4) In the event that the Consultant is unable to find some certified MBE, certified WBE, certified SBE, certified EBE, certified DVBE, and OBE sub-bid prospects for each trade, the Consultant should contact the Office of Contract Compliance at (213) 847-2684 for assistance prior to certifying under penalty of perjury that it was unable to fully meet this requirement.
3. In the event that a subcontract is reduced due to a project change that will not be specified in a change order, the Consultant shall request approval for reducing the subcontract by documenting the following for submittal:
- a. The name of the company for which the subcontract reduction is requested and the dollar amount of the reduction.
 - b. The reason for the reduction. Specific details should be given in order for the Consultant's request to be processed promptly.
 - c. The Consultant shall submit all documentation to the Awarding Authority's Project Manager.

F. SUB-AGREEMENT FALSIFICATION

Falsification or misrepresentation of a sub-agreement as to company name, contract amount and/or actual work to be done by the sub-bidder/subconsultant will result in sanctions set forth in provisions pertaining to listing of subconsultants.

G. SUBMITTAL DOCUMENTS

1. MBE/WBE/SBE/EBE/DVBE/OBE Subcontractors Information Form (Schedule A)

Proposers shall submit with their proposal the MBE/WBE/SBE/EBE/DVBE/OBE Subcontractors Information Form, provided here in as Schedule A. The proposer shall list itself and the names and addresses of all firms to be used with a complete description of work or supplies to be provided by each, and the description of work to be performed.

2. MBE/WBE/SBE/EBE/DVBE/OBE Utilization Profile (Schedule B)

During the term of the contract, the consultant must submit the MBE/WBE/SBE/EBE/DVBE/OBE Utilization Profile (Schedule B) when submitting the Monthly Remittance Advice to the City.

3. Final Subcontracting Report (Schedule C)

Upon completion of the project, a summary of these records shall be prepared on the "Final Subcontracting Report" form (Schedule C) and certified correct by the

consultant or its authorized representative. The completed form shall be furnished to the Awarding Authority within 15 working days after completion of the contract.

H. RESPONSIBILITY FOR IMPLEMENTATION AND MONITORING

The Awarding Authority which acts as the City's Project Manager for the resulting contract will be the responsible entity for proper implementation and monitoring of the policy.

I. AWARD OF CONTRACT

Nothing herein restricts the discretion of the Awarding Authority to reject all proposals in accordance with Charter Section 371.

**SCHEDULE A
CITY OF LOS ANGELES
MBE/WBE/SBE/EBE/DVBE/OBE SUBCONTRACTORS INFORMATION FORM**

(NOTE: COPY THIS PAGE AND ADD ADDITIONAL SHEETS AS NECESSARY, SIGN ALL SHEETS)

Project Title

Proposer	Address
Contact Person	Phone/Fax

LIST OF ALL SUBCONSULTANTS (SERVICE PROVIDERS/SUPPLIERS/ETC.)				
NAME, ADDRESS, TELEPHONE NO. OF SUBCONSULTANT	DESCRIPTION OF WORK OR SUPPLY	MBE/WBE/SBE/EBE/DVBE/OBE	CALTRANS/CITY/MTA CERT. NO.	DOLLAR VALUE OF SUBCONTRACT

PERCENTAGE OF MBE/WBE/SBE/EBE/DVBE/OBE PARTICIPATION		
	DOLLARS	PERCENT
TOTAL MBE AMOUNT	\$	%
TOTAL WBE AMOUNT	\$	%
TOTAL SBE AMOUNT	\$	%
TOTAL EBE AMOUNT	\$	%
TOTAL DVBE AMOUNT	\$	%
TOTAL OBE AMOUNT	\$	%
BASE BID AMOUNT	\$	

Signature of Person Completing this Form

Printed Name of Person Completing this Form

Title Date

MUST BE SUBMITTED WITH PROPOSAL

**SCHEDULE B
CITY OF LOS ANGELES
MBE/WBE/SBE/EBE/DVBE/OBE UTILIZATION PROFILE**

Project Title	Contract No.
----------------------	---------------------

Consultant	Address
-------------------	----------------

Contact Person	Phone/Fax
-----------------------	------------------

CONTRACT AMOUNT (INCLUDING AMENDMENTS)	THIS INVOICE AMOUNT	INVOICED TO DATE AMOUNT (INCLUDE THIS INVOICE)

MBE/WBE/SBE/EBE/DVBE/OBE SUBCONTRACTORS (LIST ALL SUBS)

NAME OF SUBCONTRACTOR	MBE/WBE/ SBE/EBE/ DVBE/OBE	ORIGINAL SUBCONTRACT AMOUNT	THIS INVOICE (AMOUNT NOW DUE)	INVOICED TO DATE (INCLUDE THIS INVOICE)	SCHEDULED PARTICIPATION TO DATE

CURRENT PERCENTAGE OF MBE/WBE/SBE/EBE/DVBE/OBE PARTICIPATION TO DATE			Signature of Person Completing this Form: _____
	DOLLARS	PERCENT	
TOTAL MBE PARTICIPATION	\$	%	Printed Name of Person Completing this Form: _____ Title: _____ Date: _____
TOTAL WBE PARTICIPATION	\$	%	
TOTAL SBE PARTICIPATION	\$	%	
TOTAL EBE PARTICIPATON	\$	%	
TOTAL DVBE PARTICIPATION	\$	%	
TOTAL OBE PARTICIPATION	\$	%	

**SCHEDULE C
CITY OF LOS ANGELES
FINAL SUBCONTRACTING REPORT**

Project Title		Contract No.
Company Name	Address	
Contact Person		Phone

Name, Address, Telephone No. of all Subconsultants Listed on Schedule B	Description of Work or Supply	MBE/WBE/SBE/EBE/DVBE/OBE	Original Dollar Value of Subcontract	Actual Dollar Value of Subcontract*

* If the actual dollar value differs from the original dollar value, explain the differences and give details.

	Total Dollars	Achieved Levels	Pledged Levels		Total Dollars	Achieved Levels	Pledged Levels
MBE Participation				WBE Participation			
SBE Participation				EBE Participation			
DVBE Participation				OBE Participation			

Signature of Person Completing this Form

Printed Name

Title

Date

SUBMIT WITHIN 15 DAYS OF PROJECT COMPLETION

MUNICIPAL LOBBYING ORDINANCE (MLO)

SECTION H**MUNICIPAL LOBBYING ORDINANCE (MLO)**

The City's Municipal Lobbying Ordinance (Ord No. 169916) requires certain individuals and entities to register with the City Ethics Commission and requires public disclosure of certain lobbying activities, including money received and spent. Additionally, for all construction contracts, public leases, or licenses of any value and duration; goods or service contracts with a value greater than \$25,000 and a term of at least three (3) months, each bidder/proposer must submit with its bid a certification, on a form (CEC Form 50) proscribed by the City Ethics Commission, that the bidder acknowledges and agrees to comply with the disclosure requirements and prohibitions established in the Los Angeles Municipal Lobbying Ordinance, if the bidder qualifies as a lobbying entity. A copy of the ordinance can be found at:

http://ethics.lacity.org/pdf/laws/law_mlo.pdf

INSTRUCTIONS:

- a. All proposers must complete the enclosed Bidder Certification form (CEC Form 50) and submit with the proposal.



City Ethics Commission
200 N Spring Street
City Hall — 24th Floor
Los Angeles, CA 90012
Mail Stop 129
(213) 978-1960

Bidder Certification CEC Form 50

*This form must be submitted to the awarding authority with your bid
or proposal for the contract noted below. Please write legibly.*

Original filing Amended filing (original signed on _____; last amendment signed on _____)

Bid/Contract/BAVN Number:

Awarding Authority (Department):

Name of Bidder:

Phone:

Address:

Email:

CERTIFICATION

I certify the following on my own behalf or on behalf of the entity named above, which I am authorized to represent:

- A. I am a person or entity that is applying for a contract with the City of Los Angeles.
- B. The contract for which I am applying is an agreement for one of the following:
 1. The performance of work or service to the City or the public;
 2. The provision of goods, equipment, materials, or supplies;
 3. Receipt of a grant of City financial assistance for economic development or job growth, as further described in Los Angeles Administrative Code § 10.40.1(h); or
 4. A public lease or license of City property where both of the following apply, as further described in Los Angeles Administrative Code § 10.37.1(l):
 - a. I provide services on the City property through employees, sublessees, sublicensees, contractors, or subcontractors, and those services:
 - i. Are provided on premises that are visited frequently by substantial numbers of the public; or
 - ii. Could be provided by City employees if the awarding authority had the resources; or
 - iii. Further the proprietary interests of the City, as determined in writing by the awarding authority.
 - b. I am not eligible for exemption from the City's living wage ordinance, as eligibility is described in Los Angeles Administrative Code § 10.37.1(l)(b).
- C. The value and duration of the contract for which I am applying is one of the following:
 1. For goods or services contracts—a value of more than \$25,000 and a term of at least three months;
 2. For financial assistance contracts—a value of at least \$100,000 and a term of any duration; or
 3. For construction contracts, public leases, or licenses—any value and duration.
- D. I acknowledge and agree to comply with the disclosure requirements and prohibitions established in the Los Angeles Municipal Lobbying Ordinance if I qualify as a lobbying entity under Los Angeles Municipal Code § 48.02.

I certify under penalty of perjury under the laws of the City of Los Angeles and the state of California that the information in this form is true and complete.

Date: _____

Signature: _____

Name: _____

Title: _____

Los Angeles Administrative Code § 10.40.1

- (h) "City Financial Assistance Recipient" means any person who receives from the City discrete financial assistance in the amount of One Hundred Thousand Dollars (\$100,000.00) or more for economic development or job growth expressly articulated and identified by the City, as contrasted with generalized financial assistance such as through tax legislation.

Categories of such assistance shall include, but are not limited to, bond financing, planning assistance, tax increment financing exclusively by the City, and tax credits, and shall not include assistance provided by the Community Development Bank. City staff assistance shall not be regarded as financial assistance for purposes of this article. A loan shall not be regarded as financial assistance. The forgiveness of a loan shall be regarded as financial assistance. A loan shall be regarded as financial assistance to the extent of any differential between the amount of the loan and the present value of the payments thereunder, discounted over the life of the loan by the applicable federal rate as used in 26 U.S.C. Sections 1274(d), 7872(f). A recipient shall not be deemed to include lessees and sublessees.

Los Angeles Administrative Code § 10.37.1

- (l) "Public lease or license".

- (a) Except as provided in (l)(b), "Public lease or license" means a lease or license of City property on which services are rendered by employees of the public lessee or licensee or sublessee or sublicensee, or of a contractor or subcontractor, but only where any of the following applies:
- (1) The services are rendered on premises at least a portion of which is visited by substantial numbers of the public on a frequent basis (including, but not limited to, airport passenger terminals, parking lots, golf courses, recreational facilities); or
 - (2) Any of the services could feasibly be performed by City employees if the awarding authority had the requisite financial and staffing resources; or
 - (3) The DAA has determined in writing that coverage would further the proprietary interests of the City.
- (b) A public lessee or licensee will be exempt from the requirements of this article subject to the following limitations:
- (1) The lessee or licensee has annual gross revenues of less than the annual gross revenue threshold, three hundred fifty thousand dollars (\$350,000), from business conducted on City property;
 - (2) The lessee or licensee employs no more than seven (7) people total in the company on and off City property;
 - (3) To qualify for this exemption, the lessee or licensee must provide proof of its gross revenues and number of people it employs in the company's entire workforce to the awarding authority as required by regulation;
 - (4) Whether annual gross revenues are less than three hundred fifty thousand dollars (\$350,000) shall be determined based on the gross revenues for the last tax year prior to application or such other period as may be established by regulation;
 - (5) The annual gross revenue threshold shall be adjusted annually at the same rate and at the same time as the living wage is adjusted under section 10.37.2 (a);
 - (6) A lessee or licensee shall be deemed to employ no more than seven (7) people if the company's entire workforce worked an average of no more than one thousand two-hundred fourteen (1,214) hours per month for at least three-fourths (3/4) of the time period that the revenue limitation is measured;
 - (7) Public leases and licenses shall be deemed to include public subleases and sublicenses;
 - (8) If a public lease or license has a term of more than two (2) years, the exemption granted pursuant to this section shall expire after two (2) years but shall be renewable in two-year increments upon meeting the requirements therefor at the time of the renewal application or such period established by regulation.

**FORM W-9, REQUEST FOR TAXPAYER IDENTIFICATION
NUMBER (TIN) AND CERTIFICATION**

SECTION I
FORM W-9
REQUEST FOR TAXPAYER IDENTIFICATION
NUMBER (TIN) AND CERTIFICATION

The Department requires Form W-9, “Request for Taxpayer Identification Number (TIN) and Certification,” from all entities (vendors, operators, concessionaires, etc.) doing business with the Department in order for the Department to conduct financial transactions with said entities, such as returning proposal deposits or processing payments.

INSTRUCTIONS:

- a. All proposers must submit Form W-9 with the proposal. The name listed on Form W-9 must match the proposer’s legal business name as listed on the Proposer’s Signature Declaration and Affidavit. The most recent Form W-9, along with instructions for completing the form, can be found at <http://www.irs.gov/Forms-&-Pubs>.



CITY OF LOS ANGELES
DEPARTMENT OF RECREATION AND PARKS

SECTION II

Compliance Documents to be submitted by Selected Proposer

AMERICAN WITH DISABILITIES ACT CERTIFICATION

**CERTIFICATION REGARDING COMPLIANCE WITH THE
AMERICANS WITH DISABILITIES ACT**

The undersigned certifies, that to the best of his/her knowledge and belief, that:

1. The Contractor/Borrower/Agency (hereafter Contractor) is in compliance with and will continue to comply with the Americans with Disabilities Act 42 U.S.C. 12101 et. seq. and its implementing regulations.
2. The Contractor will provide for reasonable accommodations to allow qualified individuals with disabilities to have access and participate in its programs, services and activities in accordance with the provisions of the Americans With Disabilities Act.
3. The Contractor will not discriminate against persons with disabilities nor against persons due to their relationship or association with a person with a disability.
4. The Contractor will require that the language of this certification be included in the award documents for all subawards at all tiers (including subcontracts, subgrants, and contracts under grants, loans and cooperative agreements) and that all subrecipients shall certify and disclose accordingly.
5. This Certification is a material representation of fact upon which the City relied when entering into this agreement.

AGREEMENT NUMBER: _____

CONTRACTOR: _____

NAME AND TITLE OF AUTHORIZED REPRESENTATIVE

SIGNATURE

DATE

BUSINESS TAX REGISTRATION CERTIFICATE

**BUSINESS TAX REGISTRATION CERTIFICATE NUMBER
OR BUSINESS TAX EXEMPTION NUMBER FORM**

All persons who do business with or within the City of Los Angeles, must first file with the Department of Finance (Tax/Permit Division), and obtain from that office a Business Tax Registration Certificate account number (BTRC) or Vendor Registration Number (VRN). Registration is renewable annually. For further information, contact the Tax and Permit Division located at 200 N. Spring St., Rm 101, Los Angeles, CA 90012 (213) 473-5901.

(Authority: Article 1, Chapter 2, Section 21.00 et seq. – LAMC)

Company Name: _____

Enter your current Business Tax Registration or Vendor Registration Number:

Old format:

ACCOUNT NUMBER								FUND	CLASS		
						-					

New format:

ACCOUNT NUMBER												FUND		CLASS						

State effective dates here: _____ to _____

If you have an application pending in the Department of Finance, and have not as yet received your number, a copy of your application must be submitted with your bid, proposal or agreement.

If you have received an exemption from the Department of Finance, provide an explanation for the exemption and the exemption number.

Exemption Number:

						-		
--	--	--	--	--	--	---	--	--

Explanation:

CHILD SUPPORT OBLIGATIONS CERTIFICATION

City of Los Angeles
CERTIFICATION OF COMPLIANCE WITH CHILD SUPPORT OBLIGATIONS

The undersigned hereby agrees that _____ will:
Name of Business

1. Fully comply with all applicable State and Federal employment reporting requirements for it employees.
2. Fully comply with and implement all lawfully served Wage and Earnings Assignment Order and Notices of Assignment.
3. Certify that the principal owner(s) of the business are in compliance with any Wage and Earnings Assignment Orders and Notices of Assignment applicable to them personally.
4. Certify that the business will maintain such compliance throughout the term of the contract.
5. This certification is a material representation of fact upon which reliance was placed when the parties entered into this transaction.
6. The undersigned shall require that the language of this Certification be included in all subcontractors and that subcontractors shall certify and disclose accordingly.

To the best of my knowledge, I declare under penalty of perjury that the foregoing is true and was executed at:

City/County/State

Date

Name of Business Address

Signature of Authorized Office or Representative Print Name

Title Telephone Number

CRO PLEDGE OF COMPLIANCE

CITY OF LOS ANGELES

PLEDGE OF COMPLIANCE WITH CONTRACTOR RESPONSIBILITY ORDINANCE

Los Angeles Administrative Code (LAAC) Section 10.40 et seq. (Contractor Responsibility Ordinance) provides that, unless specifically exempt, City contractors working under service contracts of at least \$25,000 and three months, contracts for the purchase of goods and products of at least \$100,000, contracts for the purchase of garments of at least \$25,000, and construction contracts of any amount; public lessees; public licensees; and certain recipients of City financial assistance or City grant funds, shall comply with all applicable provisions of the Ordinance. Upon award of a City contract, public lease, public license, financial assistance or grant, the contractor, public lessee, public licensee, City financial assistance recipient, or grant recipient, and any its subcontractor(s), shall submit this Pledge of Compliance to the awarding authority.

The contractor agrees to comply with the Contractor Responsibility Ordinance and the following provisions:

- (a) To comply with all federal, state, and local laws in the performance of the contract, including but not limited to laws regarding health and safety, labor and employment, wage and hours, and licensing laws, which affect employees.
- (b) To notify the awarding authority within 30 calendar days after receiving notification that any governmental agency has initiated an investigation which may result in a finding that the contractor did not comply with any federal, state, or local law in the performance of the contract, including but not limited to laws regarding health and safety, labor and employment, wage and hours, and licensing laws, which affect employees.
- (c) To notify the awarding authority within 30 calendar days of all findings by a governmental agency or court of competent jurisdiction that the contractor has violated any federal, state, or local law in the performance of the contract, including but not limited to laws regarding health and safety, labor and employment, wage and hours, and licensing laws which affect employees.
- (d) If applicable, to provide the awarding authority, within 30 calendar days, updated responses to the Responsibility Questionnaire if any change occurs which would change any response contained within the Responsibility Questionnaire and such change would affect the contractor's fitness and ability to continue the contract.
- (e) To ensure that subcontractors working on the City agreement (including contractors or subcontractors of a public lessee, licensee, sublessee, or sublicensee that perform or assist in performing services on the leased or licensed premises) shall comply with all federal, state, and local laws in the performance of the contract, including but not limited to laws regarding health and safety, labor and employment, wage and hours, and licensing laws, which affect employees.
- (f) To ensure that subcontractors working on the City agreement (including contractors or subcontractors of a public lessee, licensee, sublessee, sublicensee that perform or assist in performing services on the leased or licensed premises) submit a Pledge of Compliance.
- (g) To ensure that subcontractors working on the City agreement (including contractors or subcontractors of a public lessee, licensee, sublessee, or sublicensee that perform or assist in performing services on the leased or licensed premises) shall comply with paragraphs (b) and (c).

Failure to complete and submit this form to the Awarding Authority may result in withholding of payments by the City Controller, or contract termination.

Company Name, Address and Phone Number

Signature of Officer or Authorized Representative

Date

Print Name and Title of Officer or Authorized Representative

Awarding City Department

Contract Number

LOS ANGELES RESIDENCE INFORMATION

LOS ANGELES RESIDENCE INFORMATION

The City Council in consideration of the importance of preserving and enhancing the economic base and well-being of the City encourages businesses to locate or remain within the City of Los Angeles. This is important because of the jobs businesses generate and for the businesses taxes they remit. The City Council, January 7, 1992, adopted a motion that requires proposers to state their headquarter address as well as the percentage of their workforce residing in the City of Los Angeles.

Organization: _____

I. Corporate or Main Office Address

II. Total Number of Employees in the Organization: _____

III. Percentage of the Proposer's Total Workforce Employed within the City Of Los Angeles:

_____ ; Percentage Residing in the City: _____

IV. Address of any Branch Offices Located within the City of Los Angeles and Total Number Employed in each Los Angeles Branch:

_____	_____
_____	_____
_____	_____
_____	_____
_____	_____

V. Percentage of the Workforce in each Los Angeles Branch Office that is Employed within the City: _____ ; Percentage Residing in the City: _____

**LIVING WAGE ORDINANCE AND SERVICE CONTRACT
WORKER RETENTION ORDINANCE**

LWO/SCWRO – SUBCONTRACTOR DECLARATION OF COMPLIANCE FORM

REQUIRED DOCUMENTATION FOR ALL SUBCONTRACTS SUBJECT TO LWO

This form must be signed within **90 DAYS** of the execution of the subcontract and **RETAINED** by the **PRIME CONTRACTOR**.

TO BE FILLED OUT BY THE PRIME CONTRACTOR:	
1. Company Name: _____	Company Phone Number: _____
2. Company Address: _____	
3. Awarding Department: _____	
4. Project Name: _____	
<p>IF A SUBCONTRACTOR FAILS TO COMPLETE AND SUBMIT THIS FORM TO PRIME CONTRACTOR ON THE CITY CONTRACT, THE PRIME CONTRACTOR MAY BE DEEMED TO BE IN VIOLATION OF THE LWO AND SCWRO FOR FAILING TO ENSURE ITS SUBCONTRACTOR'S COMPLIANCE WITH THE ORDINANCES. THIS MAY RESULT IN WITHHOLDING OF PAYMENTS DUE THE PRIME CONTRACTOR, OR TERMINATION OF THE PRIME CONTRACTOR'S AGREEMENT WITH THE CITY.</p>	

THE PRIME CONTRACTOR MUST INFORM THEIR SUBCONTRACTORS OF THE FOLLOWING:

THE LIVING WAGE ORDINANCE (LWO) REQUIRES:

That a subcontractor (including a sublessee, a sublicensee, or a service contractor to a City financial assistance recipient) that works on or under the authority of an agreement subject to the Service Contractor Worker Retention Ordinance (SCWRO) and Living Wage Ordinance (LWO) **must comply with all applicable provisions of the Ordinances unless specifically approved for an exemption.**

THE SERVICE CONTRACT WORKER RETENTION ORDINANCE (SCWRO) REQUIRES:

In case of a successor service contract, a successor prime contractor and its subcontractors shall retain for a 90-day transition employment period, certain employees who have been employed by the terminated prime contractor and its subcontractor, if any, for the preceding 12 months or longer. Refer to the SCWRO Rules and Regulations, available from the Department of Public Works, Bureau of Contract Administration, Office of Contract Compliance (OCC) website - <http://bca.lacity.org>, for details regarding the wage and benefit requirements of the Ordinance.

THE LIVING WAGE ORDINANCE (LWO) REQUIRES THAT SUBJECT EMPLOYERS PROVIDE TO EMPLOYEES:

- As of July 1, 2008 a wage of at least **\$10.00 per hour with health benefits** of \$1.25 per hour, or **\$11.25 per hour without health benefits** (to be adjusted annually) (Regulation #4);
- At least **12 compensated days off per year** for sick leave, vacation or personal necessity at the employee's request (pro-rated for part-time employees) (Regulation #4);
- At least **10 additional days off per year of uncompensated time off** for sick leave (pro-rated for part-time employees) (Regulation #4); and
- Making **less than \$12.00 per hour** information of their possible **right to the federal Earned Income Tax Credit (EITC)** and make available the forms required to secure advance EITC payments from the employer (Regulation #4).

THE LIVING WAGE ORDINANCE (LWO) ALSO REQUIRES EMPLOYERS:

- To permit access to work sites for authorized City representatives to review the operation, payroll and related documents, and to provide certified copies of the relevant records upon request by the City.
- **Not to retaliate** against any employee claiming non-compliance with the provisions of these Ordinances and to **comply with federal law** prohibiting retaliation for union organizing (Regulation #4). Refer to the LWO Rules and Regulations, available from the Department of Public Works, Bureau of Contract Administration, Office of Contract Compliance (OCC) website - <http://bca.lacity.org>, for details regarding the wage and benefit requirements of the Ordinance.

TO BE FILLED OUT BY THE SUBCONTRACTOR:		
1. Company Name: _____	Company Phone Number: _____	
2. Company Address: _____		
3. Type of Service Provided by Subcontractor to Prime: _____		
4. Amount of Subcontract: _____	Subcontract Start Date: ___/___/___	End Date: ___/___/___
By signing this Declaration of Compliance, the subcontractor certifies that it will comply with all applicable provisions of the SCWRO, LWO, and their implementing Rules and Regulations, including any amendments or revisions to the Ordinances and Regulations.		
_____	_____	_____
Print Name of Person Completing This Form	Signature of Person Completing This Form	
_____	_____	_____
Title	Phone #	Date

LWO – EMPLOYEE INFORMATION FORM

REQUIRED DOCUMENTATION FOR ALL CONTRACTS SUBJECT TO LWO

This form must be submitted to the **AWARDING DEPARTMENT** within **30 DAYS** of contract execution. **INCOMPLETE SUBMISSIONS WILL BE RETURNED.**

THE LIVING WAGE ORDINANCE (LWO) REQUIRES THAT SUBJECT EMPLOYERS PROVIDE TO EMPLOYEES:

- As of July 1, 2008 a wage of at least **\$10.00 per hour with health benefits** of \$1.25 per hour, or **\$11.25 per hour without health benefits** (to be adjusted annually) (Regulation #4);
- At least **12 compensated days off per year** for sick leave, vacation or personal necessity at the employee’s request (pro-rated for part-time employees) (Regulation #4); and
- At least **10 additional days off per year of uncompensated time off** for personal or immediate illness only (pro-rated for part-time employees) (Regulation #4). Refer to the LWO Rules and Regulations, available from the Department of Public Works, Bureau of Contract Administration, Office of Contract Compliance (OCC) website, for details regarding the wage and benefit requirements of the Ordinance.
- Making **less than \$12.00 per hour** information of their possible **right to the federal Earned Income Tax Credit (EITC)** and make available the forms required to secure advance EITC payments from the employer (Regulation #4).

THE LIVING WAGE ORDINANCE (LWO) ALSO REQUIRES EMPLOYERS:

- **Not to retaliate** against any employee claiming non-compliance with the provisions of these Ordinances and to **comply with federal law** prohibiting retaliation for union organizing (Regulation #4).

TO BE FILLED OUT BY THE CONTRACTOR:

1. Company Name: _____
2. **STATE** the number of employees working ON THIS CITY CONTRACT: _____
3. **ATTACH** a copy of your company’s 1st PAYROLL under THIS CITY CONTRACT.
4. **INDICATE** (highlight, underline) on the payroll which employees are working ON THIS CITY CONTRACT.
5. Do you provide health benefits (such as medical, dental, vision, mental health, and disability insurance) to your employees? Yes No If YES:
 - 5a. **SUBMIT** a copy of the most recent health benefit premium statement(s) showing which employees receive health benefits.
 - 5b. **STATE** how much, if any, employees pay for co-premiums: \$ _____
6. **SUBMIT** a copy of your company’s current PAID time off policy for the employees working on the City contract.
7. **SUBMIT** a copy of your company’s current UNPAID time off policy for the employees working on the City contract.

FAILURE TO COMPLY WITH THESE REQUIREMENTS WILL RESULT IN WITHHOLDING OF PAYMENTS BY THE CITY CONTROLLER, OR A RECOMMENDATION TO THE AWARDING AUTHORITY FOR CONTRACT TERMINATION. ALL INFORMATION SUBMITTED IS SUBJECT TO VERIFICATION, AND FALSE INFORMATION MAY RESULT IN CONTRACT TERMINATION.

I understand that the employee information provided herein is confidential and will be used by the City of Los Angeles, Office of Contract Compliance for the purpose of monitoring the Living Wage Ordinance.

Print Name of Person Completing This Form

Signature of Person Completing This Form

Title

Phone #

Date

AWARDING DEPARTMENT USE ONLY:

Dept: _____ **Dept Contact:** _____ **Contact Phone:** _____ **Contract #:** _____

LWO – SUBCONTRACTOR INFORMATION FORM

REQUIRED DOCUMENTATION FOR ALL CONTRACTS SUBJECT TO LWO

This form must be submitted to the AWARDDING DEPARTMENT within 30 DAYS of contract execution. **INCOMPLETE SUBMISSIONS WILL BE RETURNED.**

SECTION I: CONTRACTOR INFORMATION

- 1) Company Name: _____ Contact Person: _____ Phone Number: _____
- 2) Do you have subcontractors working on this City contract? Yes No
 If NO, **This form is now complete – SIGN THE BOTTOM OF PAGE 2 AND SUBMIT TO THE AWARDDING DEPARTMENT.**
 If YES, a) **STATE** the number of your subcontractors ON THIS CITY CONTRACT: _____
 b) Fill in PART A for EACH subcontractor in Section II, continue to Section III & IV (if applicable), AND SIGN Section V.

SECTION II: SUBCONTRACTOR INFORMATION

PART A	PART B					
	CHECK OFF ONLY ONE BOX (I-VI) FOR EACH SUBCONTRACTOR (IF APPLICABLE) THEN CONTINUE ONTO SECTION III:					
	I 501 (c)(3) ¹	II One- Person Contractor ²	III CBA ³	IV Occupational License ⁴	V Small Business ⁵	VI Gov. entity ⁶
1. Subcontractor Name: _____ 2. Contact Person: _____ Phone #: _____ 3. Address: _____ 4. Purpose of Subcontract: _____ 5. Amount of Subcontract: \$ _____ 6. Term: Start Date ____/____/____ End Date ____/____/____ 7. Does the subcontract exceed \$25,000? <input type="checkbox"/> Yes <input type="checkbox"/> No 8. Is the length of the subcontract over three (3) months? <input type="checkbox"/> Yes <input type="checkbox"/> No If you checked off YES for Questions 7 AND 8, this subcontract IS SUBJECT TO THE LWO. Continue onto Part B. If you checked off NO for any questions 7 OR 8, this subcontract IS NOT SUBJECT TO THE LWO. Continue to fill in Part A for additional subs below.	<input type="checkbox"/>	<input type="checkbox"/>	<input type="checkbox"/>	<input type="checkbox"/>	<input type="checkbox"/>	<input type="checkbox"/>
1. Subcontractor Name: _____ 2. Contact Person: _____ Phone #: _____ 3. Address: _____ 4. Purpose of Subcontract: _____ 5. Amount of Subcontract: \$ _____ 6. Term: Start Date ____/____/____ End Date ____/____/____ 7. Does the subcontract exceed \$25,000? <input type="checkbox"/> Yes <input type="checkbox"/> No 8. Is the length of the subcontract over three (3) months? <input type="checkbox"/> Yes <input type="checkbox"/> No If you checked off YES for Questions 7 AND 8, this subcontract IS SUBJECT TO THE LWO. Continue onto Part B. If you checked off NO for any questions 7 OR 8, this subcontract is NOT SUBJECT TO THE LWO. Continue to fill in Part A for additional subs below.	<input type="checkbox"/>	<input type="checkbox"/>	<input type="checkbox"/>	<input type="checkbox"/>	<input type="checkbox"/>	<input type="checkbox"/>
1. Subcontractor Name: _____ 2. Contact Person: _____ Phone #: _____ 3. Address: _____ 4. Purpose of Subcontract: _____ 5. Amount of Subcontract: \$ _____ 6. Term: Start Date ____/____/____ End Date ____/____/____ 7. Does the subcontract exceed \$25,000? <input type="checkbox"/> Yes <input type="checkbox"/> No 8. Is the length of the subcontract over three (3) months? <input type="checkbox"/> Yes <input type="checkbox"/> No If you checked off YES for Questions 7 AND 8, this subcontract IS SUBJECT TO THE LWO. Continue onto Part B. If you checked off NO for any questions 7 OR 8, this subcontract is NOT SUBJECT TO THE LWO. Continue to fill in Part A for additional subs below.	<input type="checkbox"/>	<input type="checkbox"/>	<input type="checkbox"/>	<input type="checkbox"/>	<input type="checkbox"/>	<input type="checkbox"/>

SECTION II: SUBCONTRACTOR INFORMATION (continued)									
PART A				PART B					
				CHECK OFF ONLY ONE BOX (I-VI) FOR EACH SUBCONTRACTOR (IF APPLICABLE) THEN CONTINUE ONTO SECTION III:					
				I 501(c)(3) ¹	II One-Person Contractor ²	III CBA ³	IV Occupational License ⁴	V Small Business ⁵	VI Gov. entity ⁶
1. Subcontractor Name: _____ 2. Contact Person: _____ Phone #: _____ 3. Address: _____ 4. Purpose of Subcontract: _____ 5. Amount of Subcontract: \$ _____ 6. Term: Start Date ____/____/____ End Date ____/____/____ 7. Does the subcontract exceed \$25,000? <input type="checkbox"/> Yes <input type="checkbox"/> No 8. Is the length of the subcontract over three (3) months? <input type="checkbox"/> Yes <input type="checkbox"/> No If you checked off YES for Questions 7 AND 8, this subcontract IS SUBJECT TO THE LWO . Continue onto Part B . If you checked off NO for any questions 7 OR 8, this subcontract is NOT SUBJECT TO THE LWO . Continue to fill in Part A for additional subs below.				<input type="checkbox"/>	<input type="checkbox"/>	<input type="checkbox"/>	<input type="checkbox"/>	<input type="checkbox"/>	<input type="checkbox"/>
1. Subcontractor Name: _____ 2. Contact Person: _____ Phone #: _____ 3. Address: _____ 4. Purpose of Subcontract: _____ 5. Amount of Subcontract: \$ _____ 6. Term: Start Date ____/____/____ End Date ____/____/____ 7. Does the subcontract exceed \$25,000? <input type="checkbox"/> Yes <input type="checkbox"/> No 8. Is the length of the subcontract over three (3) months? <input type="checkbox"/> Yes <input type="checkbox"/> No If you checked off YES for Questions 7 AND 8, this subcontract IS SUBJECT TO THE LWO . Continue onto Part B . If you checked off NO for any questions 7 OR 8, this subcontract is NOT SUBJECT TO THE LWO .				<input type="checkbox"/>	<input type="checkbox"/>	<input type="checkbox"/>	<input type="checkbox"/>	<input type="checkbox"/>	<input type="checkbox"/>
SECTION III: SUBCONTRACTS SUBJECT TO THE LWO (AND MAY BE ELIGIBLE FOR EXEMPTIONS)									
1) If you checked off any boxes in Part B, your Subcontractor(s) is subject to the LWO, but may qualify for an LWO exemption. Review the exemptions below, and have your subcontractor fill out the form in the corresponding right-hand column. Continue to Section V , and submit this form and all supporting documentation to the Awarding Department for approval.									
2) If you did NOT check any boxes in Part B or your subs DO NOT qualify for an exemption, Continue to Section IV .									
EXEMPTION				SUPPORTING DOCUMENTATION REQUIRED					
One-person contractors, lessee, licensee 501(c)(3) non-profit organization				LW 13 – Departmental Exemption Form http://bca.lacity.org/index.cfm?nxt=ee&nxt_body=div_occ_lwo_forms.cfm					
Occupational license required Collective bargaining agreement w/supersession language				LW 10 – OCC Exemption Form http://bca.lacity.org/index.cfm?nxt=ee&nxt_body=div_occ_lwo_forms.cfm					
Small Business				LW 26 – Small Business Exemption Form (English & Spanish) http://bca.lacity.org/index.cfm?nxt=ee&nxt_body=div_occ_lwo_forms.cfm					
Governmental Entity				NONE REQUIRED.					
SECTION IV: SUBCONTRACTS SUBJECT TO THE LWO (AND NOT ELIGIBLE FOR EXEMPTIONS)									
Please have EACH of your Subcontractors that ARE SUBJECT to the LWO fill out the three forms below. Submit LW-6 and LW-18 ONLY to the Awarding Department (and supporting documentation, where applicable) and RETAIN LW-5 in your office.									
1) Employee Information Form				LW 6 - http://bca.lacity.org/index.cfm?nxt=ee&nxt_body=div_occ_lwo_forms.cfm					
2) Subcontractor Information Form				LW 18 - http://bca.lacity.org/index.cfm?nxt=ee&nxt_body=div_occ_lwo_forms.cfm					
3) Subcontractor Declaration of Compliance Form (retain)				LW 5 - http://bca.lacity.org/index.cfm?nxt=ee&nxt_body=div_occ_lwo_forms.cfm					
SECTION V: SIGNATURE									
I understand that the Subcontractor Information provided herein is confidential and will be used by the City of Los Angeles, Office of Contract Compliance for the purpose of monitoring the Living Wage Ordinance.									
Print Name of Person Completing This Form _____				Signature of Person Completing This Form _____					
Title _____		Phone # _____		Date _____					
AWARDING DEPARTMENT USE ONLY:									
Dept: _____		Dept Contact: _____		Contact Phone: _____		Contract #: _____			

¹ **Non-Profit 501(c)(3) Organizations:** A corporation claiming exemption under Section 10.37.1(g) of the LWO as a corporation organized under Section 501 (c)(3) of the United States Internal Revenue Code must provide the following additional documents in support of the application for exemption:

(A) A copy of the most recent IRS letter indicating that the contractor has been recognized as a non-profit corporation organized under section 501 (c)(3) of the United States Internal Revenue Code.

(B) An application for non-coverage or exemption, including the non-profit salary certification on the form referred to in Appendix A. The salary certification must list the salary of the corporation's chief executive officer (CEO), computed on an hourly basis, and the hourly wage rate of the lowest paid worker in the corporation. The salary of the CEO, when computed on an hourly basis, must be less than 8 times what the lowest paid worker is paid on an hourly basis. For purposes of this exemption, the "chief executive officer (CEO)" means the CEO of the 501(c)(3) corporation that entered into the agreement

² **One-Person Contractor:** A contractor may apply for exemption under Section 10.37.1(f) of the LWO if that contractor has no employees. The one-person contractor shall submit an application for non-coverage or exemption to the awarding authority on the form referred to in Appendix A with the appropriate one-person contractor certification. If, subsequent to the approval of the exemption application, the contractor hires any employees, the exemption is no longer valid. Any employee the contractor hires becomes covered by the LWO to the extent that the employee performs work on the City agreement. In such cases, the contractor shall notify the awarding authority of the change in circumstances and submit to the awarding authority all the necessary forms to comply with the LWO reporting requirements, including the employee and subcontractor information forms.

³ **Exemption by Collective Bargaining Agreement – LAAC 10.37.12:** An employer subject to provisions of the LWO may, by collective bargaining agreement (CBA), provide that the CBA, during its term, shall supersede the requirements of the LWO for those employees covered by the CBA. The provisions of the LWO should not be interpreted to require an employer to reduce the wages and benefits required by a collective bargaining agreement. All parties to the CBA must specifically waive in full or in part the benefits required by the LWO. An employer applying for this exemption shall submit a copy of the CBA. If the CBA does not specifically indicate that the LWO has been superseded, the employer shall submit written confirmation from the union representing the employees working on the agreement that the union and the employer have agreed to let the CBA supersede the LWO.

(A) Provisional Exemption from LWO during negotiation of CBA: An employer subject to the LWO may apply for Provisional Exemption from the LWO if the employer can document that: (1) the union and the employer are currently engaged in negotiations regarding the terms of the CBA; and (2) the issue of allowing the CBA to supersede the LWO has been proposed as an issue to be addressed during the negotiations. If granted, Provisional Exemption status is valid until the end of the negotiation process, including, if applicable, impasse resolution proceedings. During the negotiation process, the employer shall provide, upon request from the OCC, status reports on the progress of negotiations. At the end of the negotiation process, the employer shall provide the OCC with a copy of the final CBA to verify whether the LWO has been superseded, and the effective dates of the CBA.

(i) If the final CBA signed by the employer and the union supersedes the LWO, the employer shall be considered to be exempt from the LWO's wage and benefits provisions for the time period covered by the effective dates of the superseding CBA. The employer remains subject to all applicable provisions of the LWO for the time period not covered by the superseding CBA. If the employer has not complied with the LWO requirements during the time period not covered by the superseding CBA, the employer shall be required to make retroactive corrections for any period of non-compliance, which may include making retroactive payments to affected employees for the relevant periods of non compliance.

(ii) If the final CBA signed by the employer and the union does not supersede the LWO, the employer shall be required to comply with all applicable LWO requirements, including the wage and benefits provisions. Compliance shall also be required retroactively to the date that the employer first became subject to the LWO. If necessary, the employer shall provide retroactive payments to affected employees for any time period during which the employer did not comply with the LWO.

⁴ **Occupational license - LAAC 10.37.1(f): Exemptions for Employees Requiring Occupational Licenses:** If an employer claims that the LWO does not apply to an employee pursuant to section 10.37.1(f) because an occupational license is required of the employee to perform the work, the employer shall submit to the awarding authority, along with the application for non-coverage or exemption, a list of the employees required to possess an occupational license, the type of occupational license required, and a copy of the occupational license itself. An exemption granted under this provision exempts only the employee who must possess an occupational license to perform work on the City agreement. If an occupational license is not required of an employee to perform the work, the employee remains covered by the LWO.

⁵ **Small Business Exemptions for Public Lessees and Licensees – LAAC 10.37.1(i):** A public lessee or licensee claiming exemption from the LWO under section 10.37.1(i) shall submit the small business application for exemption form referred to in Appendix A along with supporting documentation to verify that it meets both of the following requirements:

(A) The lessee's or licensee's gross revenues from all business(es) conducted on the City premises for the calendar year prior to the date of the application for exemption do not exceed the gross annual revenue amount set by the LWO in Section 10.37.1(i). That gross revenue amount shall be adjusted annually according to the requirements of the LWO. The gross revenue amount used in evaluating whether the lessee or licensee qualifies for this exemption shall be the gross revenue amount in effect at the time the OCC receives the application for exemption.

A public lessee or licensee beginning its first year of operation on a specific City property will have no records of gross annual revenue on the City property. Under such circumstances, the lessee or licensee may qualify for a small business exemption by submitting proof of its annual gross revenues for the last tax year prior to application no matter where the business was located, and by satisfying all other requirements pursuant to these regulations and the LWO.

A lessee or licensee beginning its first year of operation as a business will have no records of gross annual revenue. Under such circumstances, the lessee or licensee may qualify for a small business exemption by satisfying all other requirements pursuant to these regulations and the LWO.

(B) The lessee or licensee employs no more than seven (7) employees.

(i) For purposes of this exemption, a lessee or licensee shall be deemed to employ a worker if the worker is an employee of a company or entity that is owned or controlled by the lessee or licensee, regardless of where the company or entity is located; or if the worker is an employee of a company or entity that owns or controls the lessee or licensee, regardless of where the company or entity is located.

Whether the lessee or licensee meets the seven (7) employee limit provided for in Section 10.37.1(i) of the LWO shall be determined using the total number of workers employed by all companies or businesses which the lessee or licensee owns or controls, or which own or control the lessee or licensee. Control means that one company owns a controlling interest in another company.

(ii) If a business operated by the lessee or licensee is part of a chain of businesses, the total number of employees shall include all workers employed by the entire chain of businesses unless the business operated by the lessee or licensee is an independently owned and operated franchise.

(iii) A public lessee or licensee shall be deemed to employ no more than seven (7) employees if its entire workforce (inclusive of those employees falling within the guidelines stated in subsections (i) and (ii) immediately above) worked an average of no more than 1,214 hours per month for at least three-fourths of the time period that the revenue limitation provided for in section 10.37.1(i) is measured.

Until the OCC approves the application for exemption, the lessee or licensee shall be subject to the LWO and shall comply with its requirements. If the OCC approves the application, the lessee or licensee shall be exempt from the requirements of the LWO for a period of two years from the date of the approval. The exemption will expire two years from the date of approval, but may be renewable in two-year increments upon meeting the requirements.

⁶ **Governmental Entities – LAAC 10.37.1(g):** Agreements with governmental entities are exempt from the requirements of the LWO. If an agreement is exempt from the LWO because the contractor is a governmental entity, subcontractors performing work for the governmental entity on the agreement are also exempt.

LWO – OCC SMALL BUSINESS EXEMPTION APPLICATION**EXEMPTION THAT REQUIRES OCC APPROVAL**

This application for exemption is for lessees and licensees only and must be submitted along with your bid or proposal to the AWARDDING DEPARTMENT. If approved, it will EXPIRE TWO (2) YEARS from the date of approval. This may be renewable in two (2) year increments upon meeting the requirements. INCOMPLETE SUBMISSIONS WILL BE RETURNED.

Los Angeles Administrative Code 10.37, the Living Wage Ordinance (LWO), presumes all City contractors (including service contractors, subcontractors, financial assistance recipients, lessees, licensees, sublessees and sublicensees) are subject to the LWO unless an exemption applies.

TO BE FILLED OUT BY THE CONTRACTOR:

1. Company Name: _____ Phone Number: _____
2. Company Address: _____
3. Are you a Subcontractor? Yes No If YES, state the name of your Prime Contractor:

4. STATE the total number of businesses you have (inside and outside the City of Los Angeles premises): _____
5. STATE the total number of businesses you have inside the City of Los Angeles premises only: _____

SECTION I: BUSINESS INFORMATION

CHECK OFF ONE BOX IN PART A THAT BEST DESCRIBES YOUR BUSINESS AND ATTACH DOCUMENTATION LISTED IN PART B:

PART A	PART B: SUPPORTING DOCUMENTATION REQUIRED
<input type="checkbox"/> I am a lessee or licensee beginning my first year of operation as a business.	None Required.
<input type="checkbox"/> I have other businesses, but this is my first year of operation on City premises. My gross annual revenues for all of my businesses are less than \$440,792 (as of July 1, 2008) for the 2007 calendar year.	ATTACH 2007 IRS Tax Returns listing gross revenues for ALL of your business(es).
<input type="checkbox"/> I have (a) business(es) on City premises, and my gross annual revenues from all my business(es) on City premises are less than \$440,792 (as of July 1, 2007) for the 2008 calendar year.	ATTACH 2007 IRS Tax Returns listing gross revenues for ALL of your business(es) ON CITY PREMISES.

If you **DID NOT** check off ANY boxes in PART A, your company IS **NOT ELIGIBLE FOR AN EXEMPTION.**

If you checked off **ANY** boxes in PART A, continue to Section II.

SECTION II: EMPLOYEE INFORMATION

CHECK OFF ANY BOX(ES) IN PART C THAT BEST DESCRIBE YOUR BUSINESS AND ATTACH DOCUMENTATION LISTED IN PART D:

PART C	PART D: SUPPORTING DOCUMENTATION REQUIRED
<input type="checkbox"/> I have LESS than Seven (7) employees in the entire company (inside AND outside the City of Los Angeles premises). <input type="checkbox"/> My company's workforce worked an average of no more than 1,214 hours per month for at least three-fourths of the calendar year.	Submit a completed Employee Worksheet for Small Business Exemption (Form OCC/LW-26B). Information on the Employee Worksheet may subsequently require verification through payroll records. OR Payrolls for the nine (9) months you would like to have reviewed.

If you **DID NOT** check off **ANY** boxes in PART C, your company IS **NOT ELIGIBLE FOR AN EXEMPTION.**

If you checked off **ANY** box in PART C, **ATTACH** supporting documentation, **SIGN**, AND **SUBMIT EXEMPTION FORM.**

By signing, the contractor certifies under penalty of perjury under the laws of the State of California that the information submitted in support of this application is true and correct to the best of the contractor's knowledge.

Print Name of Person Completing This Form _____

Signature of Person Completing This Form _____

Title _____ Phone # _____

Date _____

ANY APPROVAL OF THIS APPLICATION EXEMPTS ONLY THE LISTED CONTRACTOR FROM THE LWO DURING THE PERFORMANCE OF THIS CONTRACT. A SUBCONTRACTOR PERFORMING WORK ON THIS CONTRACT IS NOT EXEMPT UNLESS THE OFFICE OF CONTRACT COMPLIANCE HAS APPROVED A SEPARATE EXEMPTION FOR THE INDIVIDUAL SUBCONTRACTOR.

AWARDDING DEPARTMENT USE ONLY:

Dept: _____ Dept Contact: _____ Contact Phone: _____ Contract #: _____

OCC USE ONLY:

Approved / Not Approved – Reason: _____

By OCC Analyst: _____ Date: _____

SLAVERY DISCLOSURE AFFIDAVIT

SECTION R

SLAVERY DISCLOSURE ORDINANCE

Unless otherwise exempt, in accordance with the provisions of the Slavery Disclosure Ordinance, any contract awarded pursuant to this RFB/RFP/RFQ will be subject to the Slavery Disclosure Ordinance, Section 10.41 of the Los Angeles Administrative Code.

Bidders/Proposers seeking additional information regarding the requirements of the Slavery Disclosure Ordinance may visit the Bureau of Contract Administration's web site at www.bca.lacity.org.

INSTRUCTIONS:

- a. The selected Bidder/Proposer shall complete and upload the Slavery Disclosure Ordinance Affidavit (one [1] page) available on the City of Los Angeles' Business Assistance Virtual Network (BAVN) residing at www.labavn.org prior to award of a City contract.

**SAMPLE CONCESSION AGREEMENT
FOR THE OPERATION AND MAINTENANCE OF THE GREEK THEATRE
FOOD AND BEVERAGE CONCESSION**

Between

**THE CITY OF LOS ANGELES
DEPARTMENT OF RECREATION AND PARKS**

And

CONCESSIONAIRE NAME

TABLE OF CONTENTS

1.	DEFINITIONS.....	2
2.	PERMISSION GRANTED	3
3.	PREMISES.....	4
4.	TERM OF AGREEMENT.....	4
5.	TIME OF EXECUTION.....	4
6.	REVENUE-SHARING PAYMENT	5
7.	ADDITIONAL FEES AND CHARGES	8
8.	HOURS / DAYS OF OPERATION.....	8
9.	OPERATING RESPONSIBILITIES.....	9
10.	MAINTENANCE OF PREMISES.....	18
11.	IMPROVEMENTS	21
12.	LIABILITY	22
13.	PROHIBITED ACTS.....	25
14.	NUMBER OF ORIGINALS.....	26
15.	INDEPENDENT CONTRACTORS / CONSULTANTS.....	27
16.	PERFORMANCE DEPOSIT	27
17.	TAXES, PERMITS, AND LICENSES.....	28
18.	ASSIGNMENT, SUBLEASE, BANKRUPTCY.....	29
19.	BUSINESS RECORDS	29
20.	REGULATIONS, INSPECTION, AND DIRECTIVES.....	31
21.	TERMINATION.....	36
22.	SURRENDER OF POSSESSION	40
23.	WAIVER	41
24.	CONDITIONS AND COVENANTS	41
25.	FORCE MAJEURE.....	41
26.	REMEDIES ARE NON-EXCLUSIVE	41
27.	AGREEMENT BINDING UPON SUCCESSORS.....	41
28.	LAW OF CALIFORNIA APPLIES	41
29.	AGENT FOR SERVICE OF PROCESS	42
30.	VENUE	42
31.	WAIVER OF CLAIMS	42
32.	NOTICES	42
33.	INTERPRETATION	43
34.	AGREEMENT CONTAINS ENTIRE AGREEMENT.....	44
35.	TIME OF THE ESSENCE.....	44
36.	ACCEPTANCE OF PREMISES.....	44
37.	INCORPORATION OF DOCUMENTS	44
38.	SIGNATURE PAGE.....	45

AGREEMENT FOR THE OPERATION AND MAINTENANCE OF THE
GREEK THEATRE FOOD AND BEVERAGE CONCESSION

Between

THE CITY OF LOS ANGELES
DEPARTMENT OF RECREATION AND PARKS

And

CONCESSIONAIRE NAME

THIS Concession Agreement (hereinafter "AGREEMENT") is made and entered in this _____ day of _____, 20XX, by and between the CITY OF LOS ANGELES, a municipal corporation (hereinafter referred to as the CITY), acting by and through its Board of Recreation and Park Commissioners (hereinafter referred to as BOARD), and *CONCESSIONAIRE NAME* (hereinafter referred to as CONCESSIONAIRE).

WHEREAS, the principal purpose of the CITY in entering into this AGREEMENT is to serve the public by providing the sale of food and beverages at the Greek Theatre Food and Beverage Concession (hereinafter "CONCESSION"); and

WHEREAS, the Department of Recreation and Parks (hereinafter "DEPARTMENT") advertised for proposals for the operation and maintenance of a food and beverage CONCESSION at the Greek Theatre; and

WHEREAS, BOARD in its capacity as the contract awarding authority for the Department, finds, pursuant to Charter Section 371 (e) (10), that the use of competitive bidding would be undesirable, impractical or otherwise excused by the common law and the Charter because, unlike the purchase of a specified product, there is no single criterion, such as price comparison, that will determine which proposer can best provide the services required by the Department for the improvement, operation and maintenance of the Department's concession. To select the best proposer for this concession, the Board finds it is necessary to utilize a standard request for proposals process and to evaluate proposals received based upon the criteria included in this Request for Proposals (RFP). The Board specifically finds that the narrower and more specialized competitive sealed proposal process authorized but not required by Charter Section 371, subsection(b), would not meet the Department's needs and therefore opts to utilize the standard request for proposals process; and

WHEREAS, the DEPARTMENT received and carefully analyzed XX proposal(s) received on *MONTH DAY, YEAR*; and

WHEREAS, the CONCESSIONAIRE desires to secure and enter into an AGREEMENT in accordance with the foregoing and undertakes to provide services of the type and

character required therein by the CITY to meet the needs of the public at the Greek Theatre; and

WHEREAS, the BOARD, in accordance with Charter Section 1022, has found that the DEPARTMENT does not have personnel available in its employ with sufficient time and expertise to undertake these specialized professional tasks and that it is more feasible and more economical to secure these services by contract;

NOW THEREFORE, in consideration of the geographical area, as defined in Section 3 of this AGREEMENT (hereinafter "PREMISES") and of the terms, covenants and conditions hereinafter contained to be kept and performed by the respective parties, it is agreed as follows:

SECTION 1. DEFINITIONS

For the purpose of this AGREEMENT, the following words and phrases are defined and shall be construed as hereinafter set for:

AGREEMENT: This Concession Agreement consisting of forty-five (45) pages and seven (7) exhibits (A-G) attached hereto.

BOARD: Board of Recreation and Park Commissioners

CITY: The City of Los Angeles, acting by and through its Board of Recreation and Park Commissioners

CONCESSION: Greek Theatre Food and Beverage Concession, the permitted operation granted by this AGREEMENT

CONCESSIONAIRE: *Concessionaire Name*

DEPARTMENT: The Department of Recreation and Parks, acting through the Board of Recreation and Park Commissioners.

FACILITY: The Department of Recreation and Parks facility at which the concession is permitted to operate.

GENERAL MANAGER: The General Manager of the Department of Recreation and Parks, or that person's authorized representative, acting on behalf of CITY. All actions of the GENERAL MANAGER are subject to review at the pleasure of the Board of Recreation and Park Commissioners.

LAAC: The Los Angeles Administrative Code

LAMC: The Los Angeles Municipal Code

PREMISES: The geographical area, as defined in Section 3 of this AGREEMENT, in which the concession may be operated.

SECTION 2. PERMISSION GRANTED

For and in consideration of the payment of the fees and charges as hereinafter provided, and subject to all of the terms, covenants, and conditions of this AGREEMENT, CITY hereby grants to CONCESSIONAIRE, subject to all of the terms and conditions of this AGREEMENT, the exclusive right and obligation within the CONCESSION to sell food, non-alcoholic and alcoholic beverages. Patrons will be able to order food from inside the Greek Theatre, and seating may be arranged both inside and outside of the facility. Additionally, with the expressed written consent of GENERAL MANAGER, the CONCESSIONAIRE may provide mobile food carts to sell food and non-alcoholic beverage items at the Greek Theatre. The area that comprises the CONCESSION as described in Section 3 of this Agreement, located on the PREMISES, are to be used for authorized activities of the CONCESSIONAIRE and not for any other purpose without the prior written consent of GENERAL MANAGER. The address and phone number of CONCESSIONAIRE will be shown along with the notation that all complaints regarding change, food and beverage, etc., should be referred directly to the CONCESSIONAIRE.

The CONCESSION rights herein granted shall be carried on at the FACILITY solely within the limits and confines of said areas designated as PREMISES (Section 3) in this AGREEMENT. CONCESSIONAIRE, by accepting the AGREEMENT, agrees for itself, and its successors and assignees, that it will not make use of the PREMISES in any manner which might interfere with other recreational uses of the FACILITY.

The CONCESSIONAIRE is granted the exclusive right to sell food, and alcoholic and non-alcoholic beverages to the general public at the CONCESSION PREMISES.

In the event of a conflict between CONCESSIONAIRE and any other concessionaire or any lessee at the FACILITY regarding the services to be offered or products to be sold by respective concessionaires or lessees, GENERAL MANAGER shall meet and confer with all necessary parties to determine the services to be offered or products to be sold by each, and CONCESSIONAIRE hereunder agrees thereafter to be bound by said determination.

SECTION 3. PREMISES

The PREMISES (Exhibit A) subject to this AGREEMENT is located at: the Greek Theatre, 2700 North Vermont Avenue, Los Angeles, CA 90027.

The Concession premises are located within the Greek Theatre venue. The Concessionaire will have exclusive rights to use the following areas:

- North and South Concession Stands
- Front Plaza Area
- Upper and Lower Zeus Bars

Office and storage spaces will be provided in the basement of the Greek Theatre.

During concerts and other licensed events, the Hospitality Room and the adjacent Redwood Decks may be excluded from the food and beverage concession. Events held in the Hospitality Room and the Redwood Deck may be used by the show promoter who may bring in their own caterer. All non-concert events will use the Food and Beverage Concessionaire except for hospitality, Redwood Deck, and backstage.

Promoters will be responsible for backstage catering for the artists' entourage and crew. Unless contracted by the show promoter, the backstage catering dining and kitchen areas are excluded from this food and beverage concession.

The Department shall retain all rights to sponsorships, including non-alcoholic pouring rights, at the Greek Theatre. The successful concessionaire shall collaborate with the Department to secure and receive financial benefits from sponsorship opportunities throughout the venue.

CONCESSIONAIRE shall not use or allow the PREMISES to be used, in whole or in part, during the term of the AGREEMENT, for any use in violation of any present or future laws, ordinances, rules, and regulations at any time applicable thereto of any public or governmental authority or agencies, departments or officers thereof, including CITY, relating to sanitation or the public health, safety or welfare or operations at and use of the PREMISES.

SECTION 4. TERM OF AGREEMENT

The term of the AGREEMENT shall be one (1) year with two (2) one-year extension options exercisable at the sole discretion of the Department's General Manager and approval of Board of Recreation and Parks Commission, effective on the date of execution. Neither CITY, nor any BOARD member, officer, or employee thereof shall be liable in any manner to CONCESSIONAIRE because of any action taken to revoke, or decline to exercise an option of the AGREEMENT.

SECTION 5. TIME OF EXECUTION

Unless otherwise provided, the AGREEMENT shall be considered executed when:

- A. Said AGREEMENT has been approved by the Council of CITY of Los Angeles, Board, officer, or employee authorized to give such approval; and,
- B. Said AGREEMENT has been signed on behalf of the CONCESSIONAIRE by the person or persons authorized to bind CONCESSIONAIRE hereto; and,
- C. Said AGREEMENT has been signed on behalf of CITY by the person or persons authorized and designated to so sign by CITY's Council, Board, officer, or employee authorized to enter into the AGREEMENT.

SECTION 6. REVENUE-SHARING PAYMENT

- A. As part of the consideration for CITY's granting the concession rights hereinabove set forth, CONCESSIONAIRE shall pay to CITY a monthly revenue-sharing fee of:

The greater of:

The Annual Minimum Revenue-Sharing Guarantee, as follows:

- XX% of gross receipts of all sales
- or
- XXXXXXXX Dollars (\$X,XXX,000)

Refer to SECTION 6.C for the definition of "Gross Receipts."

Use of the PREMISES for purposes not expressly permitted herein, whether approved in writing by GENERAL MANAGER or not, may result in additional charges; however, any such use without the prior written approval of the GENERAL MANAGER shall also constitute a material breach of AGREEMENT and is prohibited.

If the annual minimum revenue-sharing is not met by December 31st of each calendar year, the difference between the actual revenue-sharing payment received by the Department and the annual minimum revenue-sharing payment will be due to the Department by January 15th of the subsequent year, pro-rated as necessary for the first year of operation or fractional part thereof, and pro-rated as necessary for the final year of operation or fractional part thereof.

- B. Revenue-Sharing Payment Due
Said payment shall be due and payable (postmarked) by the fifteenth (15th) day of each calendar month based on the gross receipts received in each previous

month. The payment and Monthly Remittance Advice Form (Section 6.D) shall be addressed to:

DEPARTMENT OF RECREATION AND PARKS
ATTENTION: Partnership and Revenue Branch/Concessions Unit
P.O. Box 86610
Los Angeles, California 90086-0610

C. Gross Receipts Defined

The term "gross receipts" is defined as the total amount charged for the sale of any goods or services (whether or not such services are performed as a part of or in connection with the sale of goods) provided in connection with this CONCESSION, but not including any of the following:

1. Cash discounts allowed or taken on sales;
2. Any sales taxes, use taxes, or excise taxes required by law to be included in or added to the purchase price and collected from the consumer or purchaser and paid by CONCESSIONAIRE;
3. California Redemption Value (CRV);
4. Receipts from the sale of waste or scrap materials resulting from the CONCESSION operation;
5. Receipts from the sale of or the trade-in value of any furniture, fixtures, or equipment used in connection with the CONCESSION, and owned by CONCESSIONAIRE;
6. The value of any merchandise, supplies, or equipment exchanged or transferred from or to other business locations of CONCESSIONAIRE where such exchanges or transfers are not made for the purpose of avoiding a sale by CONCESSIONAIRE which would otherwise be made from or at the PREMISES;
7. Refunds from, or the value of, merchandise, supplies, or equipment returned to shippers, suppliers, or manufacturers;
8. Receipts from the sale at cost of uniforms, clothing, or supplies to CONCESSIONAIRE'S employees where such uniforms, clothing, or supplies are required to be worn or used by said employees;
9. Receipts from any sale where the subject of such sale, or some part thereof, is thereafter returned by the purchaser to and accepted by CONCESSIONAIRE, to the extent of any refund actually granted or adjustment actually made, either in the form of cash or credit;

10. Fair market trade-in allowance, in the event merchandise is taken in trade;
11. The amount of any cash or quantity discounts received from sellers, suppliers, or manufacturers;
12. Discounts or surcharges applied to receipts for services or merchandise, with the concurrence of both CONCESSIONAIRE and GENERAL MANAGER, including discounts to employees, if concurred by GENERAL MANAGER;

CONCESSIONAIRE shall not reduce or increase the amount of gross receipts, as herein defined, as a result of any of the following:

13. Any error in cash handling by CONCESSIONAIRE or CONCESSIONAIRE's employees or agents;
14. Any losses resulting from bad checks received from the consumers or purchasers; or from dishonored credit, charge, or debit card payments; or any other dishonored payment to CONCESSIONAIRE by customer or purchaser;
15. Any arrangement for a rebate, kickback, or hidden credit given or allowed to customer.

D. **Monthly Revenue-Sharing Reports:**
CONCESSIONAIRE shall transmit with each revenue-sharing payment a Monthly Gross Receipts and Revenue-sharing Report, also referred to as a Monthly Remittance Advice Form (Exhibit C), for the month for which revenue-sharing payment is submitted.

E. **Late Payment Fee:**
Failure of CONCESSIONAIRE to pay any of the revenue-sharing payments or any other fees, charges, or payments required herein on time is a breach of the AGREEMENT for which CITY may terminate same or take such other legal action as it deems necessary.

Without waiving any rights available at law, in equity or under the AGREEMENT, in the event of late or delinquent payments by CONCESSIONAIRE, the latter recognizes that CITY will incur certain expenses as a result thereof, the amount of which is difficult to ascertain. Therefore, in addition to monies owing, CONCESSIONAIRE agrees to pay CITY a late fee set forth below to compensate CITY for all expenses and/or damages and loss resulting from said late or delinquent payments.

The charges for late or delinquent payments shall be Fifty Dollars (\$50.00) for each month late plus interest calculated at the rate of eighteen percent (18%) per annum, assessed monthly, on the balance of the unpaid amount. Payments shall be considered past due if postmarked after the fifteenth (15th) day of the month in which payment is due.

The acceptance of late revenue-sharing payment by CITY shall not be deemed as a waiver of any other breach by CONCESSIONAIRE of any term or condition of this AGREEMENT other than the failure of CONCESSIONAIRE to timely make the particular revenue-sharing payment so accepted.

SECTION 7. ADDITIONAL FEES AND CHARGES

- A. If CITY pays any sum or incurs any obligations or expense which CONCESSIONAIRE has agreed to pay or reimburse CITY for, or if CITY is required or elects to pay any sum or to incur any obligations or expense by reason of the failure, neglect, or refusal of CONCESSIONAIRE to perform or fulfill any one or more of the conditions, covenants, or agreements contained in the AGREEMENT, or as a result of an act or omission of CONCESSIONAIRE contrary to said conditions, covenants, and agreements, CONCESSIONAIRE agrees to pay to CITY the sum so paid or the expense so incurred, including all interest, costs, (including CITY'S fifteen percent (15%) administrative overhead cost), damages, and penalties. This amount shall be added to the revenue-sharing payment thereafter due hereunder, and each and every part of the same shall be and become additional revenue-sharing payment, recoverable by CITY in the same manner and with like remedies as if it were originally a part of the monthly revenue-sharing payment set forth in Section 6 hereof.
- B. The charges for any late or delinquent payments shall be Fifty Dollars (\$50.00) for each month late plus interest calculated at the rate of eighteen percent (18%) per annum, assessed monthly, on the balance of the unpaid amount.
- C. For all purposes under this Section, and in any suit, action, or proceeding of any kind between the parties hereto, any receipt showing the payment of any sum by CITY for any work done or material furnished shall be prima facie evidence against CONCESSIONAIRE that the amount of such payment was necessary and reasonable. Should CITY elect to use its own personnel in making any repairs, replacements, and/or alterations, and to charge CONCESSIONAIRE with the cost of same, receipts and timesheets will be used to establish the charges, which shall be presumed to be reasonable in absence of contrary proof submitted by CONCESSIONAIRE.

SECTION 8. HOURS / DAYS OF OPERATION

The Concession shall be open from:

- Concert Season: The Concession will be open a minimum of one and a half (1.5) hours before the concert and close no later than thirty (30) minutes after the concert.
- Non-concert Season: The front plaza will be open a minimum of six (6) hours for park patrons.

SECTION 9. OPERATING RESPONSIBILITIES

CONCESSIONAIRE shall, at all times during the term of the AGREEMENT, comply with the following conditions:

A. Cleanliness:

CONCESSIONAIRE shall, at its own expense, keep the PREMISES and the surrounding area, at least twenty-five (25) feet, clean and sanitary at all times. No offensive or refuse matter, nor any substance constituting an unnecessary, unreasonable, or unlawful fire hazard, nor any material detrimental to the public health, shall be permitted to remain thereon, and CONCESSIONAIRE shall prevent any such matter or material from being or accumulating upon said PREMISES.

CONCESSIONAIRE, at its own expense, shall see that all garbage or refuse is collected as often as necessary and in no case less than twice a week, and disposed of in the main dumpster. CONCESSIONAIRE shall furnish all equipment and materials necessary therefore, including trash receptacles of a size, type, and number approved by GENERAL MANAGER. If no trash storage area is made available, CONCESSIONAIRE shall provide at its own expense and with GENERAL MANAGER's prior written approval, an enclosed area concealing the trash storage from public view.

B. Conduct:

CONCESSIONAIRE and its representatives, agents, servants, and employees shall at all times conduct its business in a quiet and orderly manner to the satisfaction of GENERAL MANAGER.

C. Disorderly Persons:

CONCESSIONAIRE shall use its best efforts to permit no intoxicated person or persons, profane or indecent language, or boisterous or loud conduct in or about the PREMISES and will call upon the aid of peace officers to assist in maintaining peaceful conditions. CONCESSIONAIRE shall not knowingly allow the use or possession of illegal drugs, narcotics, or controlled substances on the PREMISES.

D. Non-Discrimination/ Equal Employment Practices/ Affirmative Action:

1. CONCESSIONAIRE, in its CONCESSION operations at the FACILITY, for itself, its personal representatives, successors in interest and assigns, as

part of the consideration hereof, does hereby covenant and agree that: (1) no person on the grounds of race, color, national origin, religion, ancestry, sex, age, physical disability, or sexual orientation shall be excluded from participation, denied the benefits of or be otherwise subjected to unjust discrimination in access to or in the use of the facilities covered by the AGREEMENT; (2) that in the construction of any improvements on, over or under the PREMISES authorized to be utilized herein and the furnishing of services thereon, no person on the grounds of race, color, national origin, religion, ancestry, sex, age, physical disability, or sexual orientation shall be excluded from participation in, denied the benefits of or otherwise be subjected to unjust discrimination.

2. CONCESSIONAIRE agrees that in the event of breach of any of the above nondiscrimination covenants, with proper notification as per Section 20, CITY shall have the right to terminate the AGREEMENT and to reenter and repossess said land and the facilities thereon and hold the same as if said AGREEMENT had never been executed.
3. In addition, CONCESSIONAIRE, during the term of the AGREEMENT, agrees not to unjustly discriminate in its employment practices against any employee or applicant for employment because of the employee's or applicant's race, color, religion, national origin, ancestry, sex, age, physical disability, or sexual orientation. All subcontracts entered into by CONCESSIONAIRE shall be approved in advance by CITY and shall contain a like provision.

E. Personnel:

1. Freedom from Tuberculosis:
For employees preparing food, and others as required by statute (reference Section 5163 of the California Public Resources Code) or directive of GENERAL MANAGER, CONCESSIONAIRE shall provide GENERAL MANAGER with certificates on applicable employees indicating freedom from communicable tuberculosis.
2. Qualified Personnel:
CONCESSIONAIRE will, in the operation of the CONCESSION, employ or permit the employment of only such personnel as will assure a high standard of service to the public and cooperation with the CITY. All such personnel, while on or about the PREMISES, shall be neat in appearance and courteous at all times and shall be appropriately attired, with badges or other suitable means of identification. No person employed by CONCESSIONAIRE, while on or about the PREMISES, shall be under the influence of illegal drugs, narcotics, other controlled substances or alcohol, or use inappropriate language, or engage in otherwise inappropriate conduct for a work environment. In the event an employee is not

satisfactory, GENERAL MANAGER may direct CONCESSIONAIRE to remove that person from the PREMISES.

3. Concession Manager:
CONCESSIONAIRE shall appoint, subject to written approval by GENERAL MANAGER, a Concession Manager of CONCESSIONAIRE's operations at the FACILITY. If CONCESSIONAIRE elects to subcontract the management of any or all of the CONCESSION operations to a managing entity or entities, the provisions of this section shall also apply to any such entity.

Such person must be a qualified and experienced manager or supervisor of operations, vested with full power and authority to accept service of all notices provided for herein and regarding operation of the CONCESSION, including the quality and prices of CONCESSION goods and services, and the appearance, conduct, and demeanor of CONCESSIONAIRE's agents, servants, and employees. The Concession Manager shall be available during regular business hours and, at all times during that person's absence, a responsible subordinate shall be in charge and available.

The Concession Manager shall devote the greater part of his or her working time and attention to the operation of the CONCESSION and shall promote, increase and develop the business. During the days and hours established for the operation of the subject concession, the Concession Manager's personal attention shall not be directed toward the operation of any other business activity.

If, for reasons of ill health, incapacitation, or death, the Concession Manager becomes incapable of performing each and all terms and provisions of the AGREEMENT, GENERAL MANAGER may, in its sole discretion, suspend the AGREEMENT and all terms and conditions contained therein.

4. Approval of Employees, Volunteers and Subcontractors:
DEPARTMENT shall have the right to approve or disapprove all employees, volunteers and subcontractors (including all employees and volunteers for any subcontractor) of CONCESSIONAIRE. Failure of CONCESSIONAIRE to obtain DEPARTMENT's written approval of all persons operating under the authority of this AGREEMENT on the PREMISES shall be a material breach of this AGREEMENT. CONCESSIONAIRE shall submit a list of all persons employed by, or volunteering or subcontracting for, CONCESSIONAIRE at the PREMISES to GENERAL MANAGER prior to commencing operations pursuant to this AGREEMENT. All changes to the approved list of employees, volunteers and subcontractors shall be submitted to GENERAL MANAGER for written approval prior to any employee, volunteer or subcontractor

commencing work at the PREMISES. CONCESSIONAIRE shall not hire as an employee or volunteer, or subcontract with, any person whom DEPARTMENT would be prohibited from hiring as an employee or volunteer pursuant to California Public Resources Code Section 5164 to perform work at the PREMISES. Each employee, volunteer or subcontractor (including all employees or volunteers of any subcontractor) shall be required to fill out a form requesting the information required by Section 5164, and DEPARTMENT reserves the right to fingerprint and conduct a Department of Justice criminal background check on any such person prior to approving their employment, volunteer service or subcontract. Failure to comply with this hiring standard shall be a material breach of this AGREEMENT and CONCESSIONAIRE shall immediately remove any employee, volunteer or subcontractor from the PREMISES at DEPARTMENT's instruction.

F. Price Schedules and Merchandising:

1. CITY agrees that CONCESSIONAIRE'S merchandise, including its price for same, shall be within CONCESSIONAIRE'S discretion; subject, however, to disapproval by GENERAL MANAGER if the selection of items offered is inadequate, of inferior quality, or if any of said prices are excessively high or low in the sole opinion of GENERAL MANAGER. Such determination shall not be unreasonable and shall take into account the business considerations presented by CONCESSIONAIRE. All prices shall be comparable to prices charged in similar establishments in the CITY. CONCESSIONAIRE shall, upon execution of AGREEMENT, provide GENERAL MANAGER with a list of prices for all merchandise and services. This list shall be updated whenever prices are changed.
2. All menu items and service, offered for sale and/or sold by CONCESSIONAIRE in said PREMISES, shall be of high quality and must be related to the ordinary business of the CONCESSION. No adulterated, misbranded, or impure articles shall be sold or kept for sale by CONCESSIONAIRE. All merchandise kept for sale by the CONCESSIONAIRE shall be kept subject to the approval or rejection of GENERAL MANAGER and CONCESSIONAIRE shall remove from the PREMISES any article which may be rejected and shall not again offer it for sale without the written approval of GENERAL MANAGER. GENERAL MANAGER may order the improvement of the quality of any merchandise kept or offered for sale.
3. CONCESSIONAIRE shall offer for sale to the public a full range of fresh and pre-packaged food items and beverages (alcoholic and non-alcoholic).
4. CONCESSIONAIRE shall sell food items and beverages from mobile food carts in the front plaza with the written approval of GENERAL MANAGER.

5. CONCESSIONAIRE shall offer for sale to the public an appropriate selection of food and refreshment items, which includes a variety of healthy choice options for food and beverages. This includes the availability of fresh fruits and fresh vegetables, bottled water, 100% juice, beverages that contain at least 50% fruit juice with no added sweeteners, and providing healthy snacks as defined by the Education Code (Part 27, Chapter 9, Article 2.5, Section 49431(b), Subsections 2 and 3). CONCESSIONAIRE expressly agrees to comply with all CITY and RAP food programs.
6. CONCESSIONAIRE shall not use artificial trans-fat (e.g., industrially created partial hydrogenation plant oils) in the preparation of food products. All prepared food items are to be free of artificial trans-fat. CONCESSIONAIRE shall attempt to use only artificial trans-fat free prepackaged food items.
7. The sale of liquor, beer, and wine is permitted. CONCESSIONAIRE is solely responsible for obtaining all necessary licenses and permits for the sale of such items.
8. The sale of energy drinks are prohibited.
9. Concessionaire will implement the proposed plan for Food and Beverage guidelines outlined in CONCESSIONAIRE's Proposal (proposed plan will become Exhibit B to this Agreement). All food/beverage subcontractors selected by the CONCESSIONAIRE shall be subject to the approval of GENERAL MANAGER.

All merchandise sold or kept for sale by CONCESSIONAIRE shall be of first class, high-quality and acceptable to all industry standards and conform to all federal, state, and municipal laws, ordinances, and regulations in every respect. No imitation, adulterated, misbranded, or impure articles shall be sold or kept for sale by CONCESSIONAIRE and all edible merchandise kept on hand shall be stored and handled with due regard for sanitation. CONCESSIONAIRE shall comply with the Good Food Purchasing Policy.

In addition, no substitutes, fillers, dilutants, nor reduction in size of standard manufactured or processed food products will be permitted. All merchandise kept for sale by CONCESSIONAIRE shall be kept subject to the approval or rejection of GENERAL MANAGER, and CONCESSIONAIRE shall remove from the PREMISES any article, which may be rejected and shall not offer it for sale without the consent of GENERAL MANAGER. GENERAL MANAGER may order the improvement of the quality of any merchandise kept or offered for sale.

10. CONCESSIONAIRE shall minimize the paper items (straw covers, serving cartons, etc.) distributed with take-out CONCESSION products. CONCESSIONAIRE shall be prohibited from selling merchandise in non-recyclable bottles, and shall not dispense take-out food or beverage items in glass or Expanded Polystyrene (EPS) / Styrofoam containers. CONCESSIONAIRE shall not sell or give away or otherwise dispose of any commodity which in the opinion of GENERAL MANAGER will cause undue litter. CONCESSIONAIRE expressly agrees to comply with all CITY and DEPARTMENT recycling programs.
 11. CONCESSIONAIRE shall not sell lottery tickets or similar type merchandise.
- G. Diversion of Business:
CONCESSIONAIRE shall not divert, cause, allow, or the AGREEMENT to be diverted any business from the PREMISES and shall take all reasonable measures, in every proper manner, to develop, maintain, and increase the business conducted by it under the AGREEMENT.
- H. Equipment, Furnishings, and Expendables:
All equipment, furnishings, and expendables required for said CONCESSION shall be purchased and installed by CONCESSIONAIRE at its sole expense and shall remain its personal property. CITY will provide a prefabricated building for use on the PREMISES. If, upon termination of the AGREEMENT, CITY does not renew said AGREEMENT, CONCESSIONAIRE shall have the right to remove its own equipment, furnishings, and expendables, but not improvements, from the PREMISES and shall be allowed a period of thirty (30) calendar days to complete such removal. If not removed within that period, said equipment, furnishings and expendables shall become the property of CITY.
- I. Maintenance of Equipment:
CONCESSIONAIRE shall, at all times and at its expense, keep and maintain all equipment, whether owned and/or installed by CONCESSIONAIRE or CITY, such as, but not limited to, heat exchangers, fans, controls and electric panels, installed by CITY, together with all of the fixtures, plate and mirror glass, equipment and personal property therein, in good repair and in a clean, sanitary, and orderly condition and appearance. CITY will be responsible for utility lines and repairs, including telephone, exterior to the PREMISES.

All maintenance, repairs and replacements of all equipment shall be performed at the sole expense of the CONCESSIONAIRE. CONCESSIONAIRE may elect not to use City-owned equipment, with prior written consent of GENERAL MANAGER.

No equipment provided by CITY shall be removed or replaced by CONCESSIONAIRE without the prior written consent of GENERAL MANAGER, and if consent is secured, such removal and/or replacement shall be at the expense of CONCESSIONAIRE.

J. Claims for Labor and Materials:

The CONCESSIONAIRE shall promptly pay when due all amounts payable for labor and materials furnished in the performance of the AGREEMENT so as to prevent any lien or other claim under any provision of law from arising against any CITY property (including reports, documents, and other tangible matter produced by CONCESSIONAIRE hereunder), against CONCESSIONAIRE's rights hereunder, or against CITY, and shall pay all amounts due under the Unemployment Insurance Act with respect to such labor.

K. Signs and Advertisements:

CONCESSIONAIRE shall not erect, construct, or place any signs, banners, ads, or displays of any kind whatsoever upon any portion of CITY property without the prior written approval from GENERAL MANAGER. Certain signs and advertisements may also require the prior written approval of the Cultural Affairs Department or other appropriate agencies.

On signage at FACILITY, CONCESSIONAIRE shall provide credit, or as proportions of signage allow, similar credit as approved by RAP in writing.

"In Collaboration with the City of Los Angeles Department of Recreation and Parks"

RAP may require removal or refurbishment, at ORGANIZATION's expense, of any sign previously approved.

Upon the expiration or termination of the AGREEMENT, CONCESSIONAIRE shall, at its own expense, remove or paint out, as GENERAL MANAGER may direct, any and all of its signs and displays on the PREMISES and in connection therewith, and shall restore said PREMISES and improvements thereto to the same condition as prior to the placement of any such signs or displays.

L. Utilities:

The DEPARTMENT shall be responsible for utility charges associated with the CONCESSION, with the exception of telephone, internet and trash pick-up. Charges for telephone, internet and trash pick-up shall be paid by CONCESSIONAIRE regardless of whether such utility services are furnished by CITY or by other utility service providers.

CONCESSIONAIRE hereby expressly waives all claims for compensation, or for any diminution or abatement of the revenue-sharing payment provided for herein, for any and all loss or damage sustained by reason of any defect, deficiency, or

impairment of the water, heating, or air conditioning systems, electrical apparatus, or wires furnished to the PREMISES which may occur from time to time and from any cause or from any loss resulting from water, earthquake, wind, civil commotion, or riot; and CONCESSIONAIRE hereby expressly releases and discharges CITY and its officers, employees, and agents from any and all demands, claims, actions, and causes of action arising from any of the aforesaid causes.

In all instances where damage to any utility service line is caused by CONCESSIONAIRE, its employees, contractors, sub-contractors, suppliers, agents, or invitees, CONCESSIONAIRE shall be responsible for the cost of repairs and any and all damages occasioned thereby.

Water and electricity shall be utilized by CONCESSIONAIRE in the most efficient manner possible, and CONCESSIONAIRE expressly agrees to comply with all CITY water and electrical conservation programs.

The CONCESSIONAIRE shall reimburse the DEPARTMENT if any telephone, internet or trash pick-up charges are paid by the DEPARTMENT.

M. Vending Machines:

CONCESSIONAIRE shall not install, or allow to be installed, any vending machines, electronic games, or other coin-operated machines without prior written approval of GENERAL MANAGER. GENERAL MANAGER shall have the right to order the immediate removal of any unauthorized machines.

N. Safety:

CONCESSIONAIRE shall correct safety deficiencies, and violations of safety practices, immediately after the condition becomes known or GENERAL MANAGER notifies CONCESSIONAIRE of said condition. CONCESSIONAIRE shall cooperate fully with CITY in the investigation of accidents occurring on the PREMISES. In the event of injury to a patron or customer, CONCESSIONAIRE shall reasonably ensure that the injured person receives prompt and qualified medical attention, and as soon as possible thereafter, CONCESSIONAIRE shall submit a CITY Form General No. 87 "Non-Employee Accident or Illness Report" (see SECTION 32, "NOTICES," for mailing address) (Exhibit E). If CONCESSIONAIRE fails to correct hazardous conditions specified by GENERAL MANAGER in a written notice, which have led, or in the opinion of CITY could lead, to injury, GENERAL MANAGER may, in addition to all other remedies which may be available to CITY, repair, replace, rebuild, redecorate, or paint any such PREMISES to correct the specified hazardous conditions, with the cost thereof, plus fifteen percent (15%) for administrative overhead, to be paid by CONCESSIONAIRE to CITY on demand.

- O. Environmental Sensitivity:
The CONCESSIONAIRE must operate the CONCESSION in an environmentally sensitive manner and all operations must comply with CITY policies regarding protection of the environment. CONCESSIONAIRE shall not use or allow the use on the PREMISES of environmentally unsafe products.
- P. Fund Raising And/Or Special Events Activities:
CONCESSIONAIRE will be expected to cooperate with DEPARTMENT personnel on all matters relative to the conduct of fund-raising and/or special events, as well as use of these areas by the film industry. CONCESSIONAIRE may be required to cease operations or to allow for fund-raising and/or special events at the discretion of GENERAL MANAGER.
- Q. Quiet Enjoyment:
CITY agrees that CONCESSIONAIRE, upon payment of the fees and charges specified herein, and all other charges and payments to be paid by CONCESSIONAIRE under the terms of this AGREEMENT, and upon observing and keeping the required terms, conditions and covenants of this AGREEMENT, shall lawfully and quietly hold, use and enjoy the CONCESSION PREMISES during the term of this AGREEMENT. In the case of disputes, during the life of the AGREEMENT, over any conditions which may impede upon the CONCESSIONAIRE's quiet enjoyment of the CONCESSION PREMISES, GENERAL MANAGER shall have final determination of any solution to such dispute; GENERAL MANAGER'S final determination shall be binding upon all parties in such dispute.

R. Receipts:

1. CONCESSIONAIRE shall offer receipts to customers for every transaction.
2. CONCESSIONAIRE shall at all times have a sign placed within twelve (12) inches of any cash register, in clear view to the public, and in minimum one-inch lettering, which states: "If a receipt for this transaction is not provided, please contact Department of Recreation and Parks - Concessions Unit at (213) 202-3280."

SECTION 10. MAINTENANCE OF PREMISES

During all periods that the PREMISES are used or are under the control of the CONCESSIONAIRE for the uses, purposes, and occupancy aforesaid, CONCESSIONAIRE shall be responsible for all necessary janitorial duties and damage/maintenance repairs, to the satisfaction of GENERAL MANAGER. The cause of said maintenance, cleaning and repairs may result from normal wear and tear, as well as vandalism.

A. Interior of Premises:

1. Areas to be Maintained by CONCESSIONAIRE:
Subject to written approval by GENERAL MANAGER, the CONCESSIONAIRE shall, at its own expense, keep and maintain all the interior walls and surfaces of PREMISES and all improvements, fixtures, and utility systems which may now or hereafter exist thereon, whether installed by CITY or CONCESSIONAIRE. Improvements shall include all buildings and appurtenances recessed into or attached by any method to the ground or to another object which is recessed or attached to the ground or to other CITY-owned facilities (such as buildings, fences, posts, signs, electrical hook-ups, plumbing, tracks, tanks, etc.).
2. Duties:
CONCESSIONAIRE'S maintenance duties shall include all sweeping, washing, servicing, repairing, replacing, cleaning, and interior painting that may be required to properly maintain the premises in a safe, clean, operable, and attractive condition. CONCESSIONAIRE shall provide for such repairs, replacements, rebuilding, and restoration as may be required by or given prior written approval by GENERAL MANAGER to comply with the requirements hereof. Those duties shall also include electrical, mechanical, and plumbing maintenance in the interior of the premises, such as light fixtures, toilets, and faucets.

- B. Exterior of Premises and Common Passageways:
CITY shall maintain the exterior of all buildings and will endeavor to perform all exterior repairs occasioned by normal wear and tear, and the elements, unless otherwise provided for in the AGREEMENT. Common passageways leading to other CONCESSION facilities or offices maintained by CITY which also lead to the PREMISES shall not be considered under the control of CONCESSIONAIRE for purposes of this Section.
- C. Correction of Conditions Leading to Damage:
If CONCESSIONAIRE fails, after written notice, to correct such conditions which have led or, in the opinion of CITY, could lead to significant damage to CITY property, GENERAL MANAGER may at its option, and in addition to all other remedies which may be available to it, repair, replace, rebuild, redecorate or paint any such PREMISES included in said notice, with the cost thereof, plus fifteen percent (15%) for administrative overhead, to be paid by CONCESSIONAIRE to CITY on demand. If, for any reasons, payment of such fees becomes delinquent, GENERAL MANAGER may, in its sole discretion, suspend the AGREEMENT and all terms and conditions contained therein.
- D. Property Damage and Theft Reporting:
CONCESSIONAIRE shall complete and submit to DEPARTMENT a "Special Occurrence and Loss Report," (Exhibit H) in the event that the PREMISES and/or CITY-owned property is damaged or destroyed, in whole or in part, from any cause whatsoever, and in the event of theft, burglary, or other crime committed on the PREMISES. Blank forms for this purpose shall be provided by DEPARTMENT.
- E. Damage or Destruction to Premises:
1. Partial Damage:
If all or a portion of the PREMISES are partially damaged by fire, explosion, flooding inundation, floods, the elements, public enemy, or other casualty, but not rendered uninhabitable, the same will be repaired with due diligence by CITY at its own cost and expense, subject to the limitations as hereinafter provided; if said damage is caused by the negligent acts or omissions of CONCESSIONAIRE, its agents, officers, or employees, CONCESSIONAIRE shall be responsible for reimbursing CITY for the cost and expense incurred in making such repairs.
 2. Extensive Damage:
If the damages as described above in "Partial Damage" are so extensive as to render the PREMISES or a portion thereof uninhabitable, but are capable of being repaired within a reasonable time not to exceed sixty (60) days, the same shall be repaired with due diligence by CITY at its own cost and expense and a negotiated portion of the fees and charges payable hereunder shall abate from the time of such damage until such

time as the PREMISES are fully restored and certified by GENERAL MANAGER as again ready for use; provided, however, that if such damage is caused by the negligent acts or omissions of CONCESSIONAIRE, its agents, officers, or employees, said fees and charges will not abate and CONCESSIONAIRE shall be responsible for the cost and expenses incurred in making such repairs.

3. Complete Destruction:

In the event all or a substantial portion of the PREMISES are completely destroyed by fire, explosion, the elements, public enemy, or other casualty, or are so damaged that they are uninhabitable and cannot be replaced except after more than sixty (60) days, CITY shall be under no obligation to repair, replace or reconstruct said PREMISES, and an appropriate portion of the fees and charges payable hereunder shall abate as of the time of such damage or destruction and shall henceforth cease until such time as the said PREMISES are fully restored. If within four (4) months after the time of such damage or destruction said PREMISES have not been repaired or reconstructed, CONCESSIONAIRE may terminate this AGREEMENT in its entirety as of the date of such damage or destruction. Notwithstanding the foregoing, if the said PREMISES, or a substantial portion thereof, are completely destroyed as a result of the negligent acts or omissions of CONCESSIONAIRE, its agents, officers, or employees, said fees and charges shall not abate and CITY may, in its discretion, require CONCESSIONAIRE to repair and reconstruct the same within twelve (12) months of such destruction and CONCESSIONAIRE shall be responsible for reimbursing CITY for the cost and expenses incurred in making such repairs. CONCESSIONAIRE shall continue paying CITY revenue-sharing payment as determined above during the rebuilding of the facility.

4. Limits of CITY'S Obligation Defined:

In the application of the foregoing provisions, CITY may, but shall not be obligated to, repair or reconstruct the PREMISES. If CITY chooses to do so, CITY's obligation shall also be limited to repair or reconstruction of the PREMISES to the same extent and of equal quality as obtained by CONCESSIONAIRE at the commencement of its operations hereunder. Redecoration and replacement of furniture, equipment and supplies shall be the responsibility of CONCESSIONAIRE and any such redecoration and refurbishing/reequipping shall be equivalent in quality to that originally installed.

F. Pest Control:

Unless otherwise specified in the AGREEMENT, CONCESSIONAIRE shall be responsible for pest control in and around the PREMISES, including but not limited to, abatement of insects (including roaches, bees, etc.), spiders, rodents, vermin, and other nuisance pests, if the pests are found in or on structures or

areas used and maintained by CONCESSIONAIRE, such as any of the following portions of the PREMISES:

1. Any portion of a building or enclosed structure with walls, roof, and doors, such and any storage facilities or storage containers owned and/or used by CONCESSIONAIRE.

CITY shall be responsible for pest control if pests are found in or on structures or areas maintained by CITY, such as:

2. Open, unfenced areas such as those locations permitted for mobile food vending, bike rentals, coin-operated telescopes, etc.
3. Recreation centers, rental halls, and other facilities occupied in part by CONCESSIONAIRE but maintained by CITY.
4. Other areas, structures, or facilities adjacent to the PREMISES, but not used by or under the control of CONCESSIONAIRE; or areas, structures, or facilities shared by CONCESSIONAIRE and CITY.

Pest control for pests which may cause permanent structural damage to DEPARTMENT property (for example, termite infestation) shall be the responsibility of CITY. CONCESSIONAIRE shall take all reasonable measures to reduce the proliferation of pests, including maintaining the PREMISES clean and orderly in accordance with this Section, and keeping wood components painted. GENERAL MANAGER may direct CONCESSIONAIRE to take additional measures to abate pests which are an immediate threat to public health or safety.

SECTION 11. IMPROVEMENTS

CONCESSIONAIRE is not required to provide any improvements ("Improvements"). The award of the AGREEMENT shall not constitute approval to make any Improvements.

CITY reserves the right to further develop or improve the FACILITY and the PREMISES as it sees fit, and without interference or hindrance by CONCESSIONAIRE. Such development or improvement may require the suspension or termination of the AGREEMENT. CITY shall not be liable for loss of business which results from the construction of any development or improvements to the FACILITY or the PREMISES.

SECTION 12. LIABILITY

A. Indemnification:

Except for the active negligence or willful misconduct of CITY, CONCESSIONAIRE undertakes and agrees to defend, indemnify and hold harmless CITY and any and all of CITY's Officers, Agents, and Employees from and against all suits and causes of action, claims, losses, demands and expenses, including, but not limited to, attorney's fees and cost of litigation, damage or liability of any nature whatsoever, for death or injury to any person, including CONCESSIONAIRE'S employees and agents, or damage or destruction of any property of either party hereto or of third parties, arising in any manner by reason of, or incident to, the performance of this AGREEMENT on the part of CONCESSIONAIRE, its officers, agents, employees, or sub-contractor of any tier.

B. Insurance:

1. General Conditions:

CONCESSIONAIRE shall obtain and keep in force an insurance policy which covers all operations conducted pursuant to this AGREEMENT. Such insurance policy must also insure the CITY of Los Angeles and comply with the Office of the Administrative Officer's insurance requirements. See Exhibit D for insurance requirements. GENERAL MANAGER, based upon advice of the CITY'S Risk Manager, may increase or decrease the amounts of insurance coverage required herein by giving thirty (30) days' written notice to CONCESSIONAIRE.

Without limiting CONCESSIONAIRE'S indemnification of CITY, CONCESSIONAIRE shall provide and maintain at its own expense during the entire term of the AGREEMENT insurance having the limits customarily carried and actually arranged by CONCESSIONAIRE but not less than the amounts and types listed in the AGREEMENT covering its operations hereunder subject to the following conditions:

a. Additional Insured:

CITY, its Officers, Agents and Employees shall be included as additional insureds in all liability insurance policies except: Workers' Compensation / Employer's Liability, Professional Errors and Omissions and second-party Legal Liability coverages (such as Fire Legal). CITY shall be named Loss Payee As Its Interest May Appear in all required property, fidelity or surety coverages.

b. Insurance Requirements:

All insurance required hereunder shall conform to CITY requirements established by Charter, ordinance or policy and shall be filed with the Office of the City Attorney for its review in

accordance with Los Angeles City Administrative Code Sections 11.47 through 11.56.

- c. **Primary Insurance:**
Such insurance shall be primary with respect to any insurance maintained by CITY and shall not call on CITY's insurance program for contributions.
- d. **Admitted Carrier/Licensed California Broker:**
Such insurance shall be obtained from brokers or carriers authorized to transact insurance business in California.
- e. **30-Day Notice:**
With respect to the interest of CITY, such insurance shall not be canceled, materially reduced in coverage or limits or non-renewed except after thirty (30) days written notice by receipted delivery (e.g. certified mail-return receipt, courier) has been given to the Office of the Administrative Officer.
- f. **Prior Approval:**
Evidence of insurance shall be submitted to and approved by the Office of the Administrative Officer prior to commencement of any work or tenancy under this AGREEMENT.
- g. **Severability of Interest:**
Except with respect to the insurance company's limits of liability, each liability insurance policy shall apply separately to each insured against whom claim or suit is brought. The inclusion of any person or organization as an insured shall not affect any right which such person or organization would have as a claimant if not so included.
- h. **Acceptable Evidence:**
CONCESSIONAIRE shall submit acceptable evidence and approval of insurance in accordance with the "Instructions and Information on Complying with CITY Insurance Requirements" (Exhibit D).
- i. **Renewal:**
Once the insurance has been approved by CITY, evidence of renewal of an expiring policy may be submitted on a manually signed renewal endorsement form. If the policy or the carrier has changed, however, new evidence as specified in paragraphs a. through h. above must be submitted.
- j. **Aggregate Limits/Blanket Coverage:**

If any of the required insurance coverages contain aggregate limits, or apply to other operations or tenancy of CONCESSIONAIRE outside this AGREEMENT, CONCESSIONAIRE shall give CITY prompt, written notice of any incident, occurrence, claim, settlement or judgment against such insurance which in CONCESSIONAIRE'S best judgment will diminish the protection such insurance affords CITY. Further, CONCESSIONAIRE shall immediately take all reasonable and available steps to restore such aggregate limits or shall provide other insurance protection for such aggregate limits.

2. **Self-Insurance and Self-Insured Retentions:**
Self-insurance programs and self-insured retentions in insurance policies are subject to separate approval by CITY upon review of evidence of CONCESSIONAIRE'S financial capacity to respond. Additionally, such programs or retentions must provide CITY with at least the same protections from liability and defense of suits as would be afforded by first-dollar insurance.
3. **Modification of Coverage:**
CITY reserves the right at any time during the term of this AGREEMENT to change the amounts and types of insurance required hereunder by giving CONCESSIONAIRE ninety (90) days advance written notice of such change. If such change should result in substantial additional cost to CONCESSIONAIRE, CITY agrees to negotiate additional compensation proportional to the increased benefit to CITY.
4. **Availability/Failure to Procure Insurance:**
The required coverages and limits are subject to availability on the open market at reasonable cost as determined by CITY. Nonavailability or nonaffordability must be documented by a letter from CONCESSIONAIRE'S insurance broker or agent indicating a good faith insurance and showing as minimum the names of then insurance carriers and the declinations or quotations received from each.

Within the foregoing constraints, CONCESSIONAIRE'S failure to procure or maintain required insurance or a self-insurance program shall constitute a material breach of contract under which GENERAL MANAGER may immediately terminate or suspend this AGREEMENT or, at its discretion, procure or renew such insurance to protect CITY's interests and pay any and all premiums in connection therewith, and recover all monies so paid from CONCESSIONAIRE.
5. **Underlying Insurance:**
CONCESSIONAIRE shall be responsible for requiring indemnification and insurance as it deems appropriate from its employees receiving mileage allowance, consultants, agents and subcontractor, if any, to protect

CONCESSIONAIRE'S and CITY's interest, and for ensuring that such persons comply with applicable insurance statutes. CONCESSIONAIRE is encouraged to seek professional advice in this regard.

6. Workers' Compensation:
CONCESSIONAIRE hereby certifies that it is aware of the provisions of Section 3700 et seq., of the California Labor Code which require every employer to be insured against liability for Workers' Compensation or to undertake self-insurance in accordance with the provisions of that Code, and that it will comply with such provisions at all such times as they may apply during the performance of the work of this AGREEMENT.

Any breach of this condition for insurance requirements shall be a material breach of this AGREEMENT.

SECTION 13. PROHIBITED ACTS

CONCESSIONAIRE shall not:

1. Do or allow to be done anything which may interfere with the effectiveness or accessibility of utility, heating, ventilating, or air conditioning systems or portions thereof on the PREMISES or elsewhere on the FACILITY, nor do or permit to be done anything which may interfere with free access and passage in the PREMISES or the public areas adjacent thereto, or in the streets or sidewalks adjoining the PREMISES, or hinder police, fire fighting or other emergency personnel in the discharge of their duties;
2. Interfere with the public's enjoyment and use of the FACILITY or use the PREMISES for any purpose which is not essential to the CONCESSION operations;
3. Rent, sell, lease or offer any space for storing of any articles whatsoever within or on the PREMISES other than specified herein, without the prior written approval of GENERAL MANAGER;
4. Overload any floor in the PREMISES;
5. Place any additional lock of any kind upon any window or interior or exterior door in the PREMISES, or make any change in any existing door or window lock or the mechanism thereof, unless a key therefor is maintained on the PREMISES, nor refuse, upon the expiration or sooner termination of the AGREEMENT, to surrender to GENERAL MANAGER any and all keys to the interior or exterior doors on the PREMISES, whether said keys were furnished to or otherwise procured by CONCESSIONAIRE, and in the event of the loss of any keys furnished by

GENERAL MANAGER, CONCESSIONAIRE shall pay CITY, on demand, the cost for replacement thereof;

6. Do or permit to be done any act or thing upon the PREMISES which will invalidate, suspend or increase the rate of any insurance policy required under the AGREEMENT, or carried by CITY, covering the PREMISES, or the buildings in which the same are located or which, in the opinion of GENERAL MANAGER, may constitute a hazardous condition that will increase the risks normally attendant upon the operations contemplated under the AGREEMENT, provided, however, that nothing contained herein shall preclude CONCESSIONAIRE from bringing, keeping or using on or about the PREMISES such materials, supplies, equipment and machinery as are appropriate or customary in carrying on its business, or from carrying on said business in all respects as is customary;
7. Use, create, store or allow any hazardous materials as defined in Title 26, Division 19.1, Section 19-2510 of the California Code of Regulations, or those which meet the criteria of the above Code, as well as any other substance which poses a hazard to health and environment, provided, however, that nothing contained herein shall preclude CONCESSIONAIRE from bringing, keeping or using on or about the PREMISES such materials, supplies, equipment and machinery as are appropriate or customary in carrying on its business, or from carrying on said business in all respects as is customary except that all hazardous materials must be stored and used in compliance with all the City, State and Federal rules, regulations, ordinances and laws;
8. Allow any sale by auction upon the PREMISES;
9. Permit undue loitering on or about the PREMISES;
10. Use PREMISES in any manner will constitute waste;
11. Use or allow the PREMISES to be used for, in the opinion of GENERAL MANAGER, any improper, immoral, or unlawful purposes.

SECTION 14. NUMBER OF ORIGINALS

The number of original texts of this AGREEMENT shall be equal to the number of parties hereto, one text being retained by each party.

SECTION 15. INDEPENDENT CONTRACTORS / CONSULTANTS

The CONCESSIONAIRE is acting hereunder as an independent contractor and not as an agent or employee of the CITY. The CONCESSIONAIRE shall not represent or otherwise hold itself or any of its directors, officers, partners, employees, or agents to be an agent or employee of the CITY.

SECTION 16. PERFORMANCE DEPOSIT

CONCESSIONAIRE shall provide DEPARTMENT a sum equal to Three Hundred Thousand Dollars (\$300,000.00) to guarantee payment of fees and as a damage deposit to be used in accordance with the default provisions of this AGREEMENT.

Form of Deposit:

CONCESSIONAIRE'S Deposit shall be in any one of the following forms but may not be a combination of two or more types:

1. A cash deposit made at the Cashier's window of DEPARTMENT.
 2. A cashier's check drawn on a recognized local bank, which cashier's check is payable to the order of the City of Los Angeles.
 3. A check drawn on and certified by any recognized local bank, payable to the order of the City of Los Angeles.
- A. Agreement of Deposit and Indemnity:
The above instruments must be accompanied by an agreement of deposit and indemnity, approved as to form and legality by the City Attorney, wherein CONCESSIONAIRE unconditionally agrees that in the event of any default, CITY shall have full power and authority to use the deposit in whole or in part to indemnify CITY. All deposits of cash or checks must be immediately so deposited by DEPARTMENT.
- B. Maintenance of Deposit:
Said deposit shall be held by CITY during the entire term of the AGREEMENT.
- C. Return of Deposit to CONCESSIONAIRE:
Said Deposit shall be returned to CONCESSIONAIRE and any rights assigned to Deposit shall be surrendered by CITY in writing, after the expiration or earlier termination of the AGREEMENT and any exit audits performed in conjunction with the AGREEMENT. The CITY reserves the right to deduct from the Deposit, any amounts up to and including the full amount of the Deposit as stated herein, owed to the CITY by CONCESSIONAIRE as shown by any exit audits performed by CITY, or as compensation to CITY for failure to adhere to the terms and conditions of the AGREEMENT.

SECTION 17. TAXES, PERMITS, AND LICENSES

- A. CONCESSIONAIRE shall obtain and maintain at its sole expense any and all approvals, permits, or licenses that may be required in connection with the operation of the CONCESSION including, but not limited to, tax permits, business licenses, health permits, building permits, police and fire permits, etc.
- B. CONCESSIONAIRE shall pay all taxes of whatever character that may be levied or charged upon the rights of CONCESSIONAIRE to use the PREMISES, or upon CONCESSIONAIRE'S improvements, fixtures, equipment, or other property thereon or upon CONCESSIONAIRE'S operations hereunder. In addition, by executing the AGREEMENT and accepting the benefits thereof, a property interest may be created known as "Possessory Interest" and such property interest will be subject to property taxation. CONCESSIONAIRE, as the party to whom the Possessory Interest is vested, may be subject to the payment of the property taxes levied by the State and County upon such interest.
- C. During the entire term of the AGREEMENT, the CONCESSIONAIRE must hold a current Los Angeles Business Tax Registration Certificate (BTRC) as required by the CITY'S Business Tax Ordinance (LAMC Article 1, Chapter 2, Sections 21.00 et. seq.).
- D. Pursuant to Section 21.3.3 of Article 1.3 of the LAMC Commercial Tenants Occupancy Tax, CONCESSIONAIRE must pay to the City of Los Angeles for the privilege of occupancy, a tax at the rate of One Dollar and Forty-Eight Cents (\$1.48) per calendar quarter or fractional part thereof for the first One Thousand Dollars (\$1,000.00) or less of charges (revenue-sharing rent) attributable to said calendar quarter, plus One Dollar and Forty-Eight Cents (\$1.48) per calendar quarter for each additional One Thousand Dollars (\$1,000.00) of charges or fractional part thereof in excess of One Thousand Dollars (\$1,000.00). Said tax shall be paid quarterly to DEPARTMENT, on or before the fifteenth (15th) of April, July, October, January of each calendar year, for the preceding three (3) months. Should the rate of the Occupancy Tax rise at any time during the term of the AGREEMENT, the CONCESSIONAIRE shall be responsible to pay the updated, higher rate.

The charges for late or delinquent Occupancy Tax payments shall be Fifty Dollars (\$50.00) for each month late plus interest calculated at the rate of eighteen percent (18%) per annum, assessed monthly, on the balance of the unpaid amount.

SECTION 18. ASSIGNMENT, SUBLEASE, BANKRUPTCY

CONCESSIONAIRE shall not under-let or sub-let the subject PREMISES or any part thereof or allow the same to be used or occupied by any other person or for other use than that herein specified, nor assign the AGREEMENT nor transfer, assign or in any manner convey any of the rights or privileges herein granted without the prior written consent of CITY. Neither the AGREEMENT nor the rights herein granted shall be assignable or transferable by any process or proceedings in any court, or by attachment, execution, proceeding in insolvency or bankruptcy either voluntary or involuntary, or receivership proceedings. Any attempted assignment, mortgaging, hypothecation, or encumbering of the CONCESSION rights or other violation of the provisions of this Section shall be void and shall confer no right, title or interest in or to the AGREEMENT or right of use of the whole or any portion of the PREMISES upon any such purported assignee, mortgagee, encumbrancer, pledgee or other lien holder, successor or purchaser.

The CONCESSIONAIRE may not, without prior written permission of the CITY:

- A. Assign or otherwise alienate any of its rights hereunder, including the right to payment; or
- B. Delegate, subcontract, or otherwise transfer any of its duties hereunder.

SECTION 19. BUSINESS RECORDS

CONCESSIONAIRE shall maintain during the term of the AGREEMENT and for three (3) years thereafter, all of its books, ledgers, journals, and accounts wherein are kept all entries reflecting the gross receipts received or billed by it from the business transacted pursuant to the AGREEMENT. Such books, ledgers, journals, accounts, and records shall be available for inspection and examination by GENERAL MANAGER, or a duly authorized representative, during ordinary business hours at any time during the term of this AGREEMENT and for at least three (3) years thereafter.

- A. Employee Fidelity Bonds:
At GENERAL MANAGER's discretion, adequate employee fidelity bonds may be required to be maintained by CONCESSIONAIRE covering all its employees who handle money.
- B. Cash And Record Handling Requirements:
If requested by GENERAL MANAGER, CONCESSIONAIRE shall prepare a description of its cash handling and sales recording systems and equipment to be used for operation of the CONCESSION which shall be submitted to GENERAL MANAGER for approval.

CONCESSIONAIRE shall be required to maintain a method of accounting of the CONCESSION which shall correctly and accurately reflect the gross receipts and disbursements received or made by CONCESSIONAIRE from the operation of the CONCESSION. The method of accounting, including bank accounts,

established for the CONCESSION shall be separate from the accounting systems used for any other business operated by CONCESSIONAIRE or for recording CONCESSIONAIRE'S personal financial affairs. Such method shall include the keeping of the following documents:

1. Regular books of accounting such as general ledgers.
2. Journals including supporting and underlying documents such as vouchers, checks, tickets, bank statements, etc.
3. State and Federal income tax returns and sales tax returns and checks and other documents proving payment of sums shown.
4. Cash register tapes shall be retained so that day to day sales can be identified. A cash register must be used in public view which prints a dated double tape, indicating each sale and the daily total.
5. Any other accounting records that CITY, in its sole discretion, deems necessary for proper reporting of receipts.

C. Method of Recording Gross Receipts:

Unless otherwise specified in the AGREEMENT, CONCESSIONAIRE shall obtain and install a cash register(s) on which it shall record all gross sales. The cash register shall be non-resettable and sufficient to supply an accurate recording of all sales on tape. CONCESSIONAIRE shall not purchase or install the cash register before obtaining GENERAL MANAGER's written approval of the specific register to be purchased. All cash registers shall have a price display which is and shall remain at all times visible to the public.

In lieu of a cash register as described directly above, the CONCESSIONAIRE may install a computerized Point-of-Sale system, including hardware and software, to record transactions and receipts. Such computerized Point-of-Sale system must be capable of providing paper receipts to patrons, have a price display which is and shall remain at all times visible to the public, and have controls in place to make it equivalent to a non-resettable cash register. CONCESSIONAIRE shall not purchase or install the computerized Point-of-Sale system, including hardware and software, before obtaining GENERAL MANAGER's written approval of the specific hardware and software to be purchased.

- D. Annual Statement of Gross Receipts and Expenses:
CONCESSIONAIRE shall transmit a Statement of Gross Receipts and Expenses (Profit and Loss Statement) for the CONCESSION operations as specified in the AGREEMENT, in a form acceptable to GENERAL MANAGER, on or before April 30th of each calendar year during the term of the AGREEMENT. Such Statement must be prepared by a Certified Public Accountant (CPA) and shall not include statements of omission or non-disclosure. An extension may be granted in writing, prior to the April 30th due date, by GENERAL MANAGER or his designee, provided sufficient verification of the need for the extension is provided, as accepted by GENERAL MANAGER. The charge for late or delinquent Profit and Loss Statements shall be Fifty Dollars (\$50.00) per month or part thereof late.

In addition, CITY may from time to time conduct an audit and re-audit of the books and businesses conducted by CONCESSIONAIRE and observe the operation of the business so that accuracy of the above records can be confirmed. If the report of gross sales made by CONCESSIONAIRE to CITY shall be found to be less than the amount of gross sales disclosed by such audit and observation, CONCESSIONAIRE shall pay CITY within thirty (30) days after billing any additional revenue-sharing payments disclosed by such audit. If discrepancy exceeds two percent (2%) and no reasonable explanation is given for such discrepancy, CONCESSIONAIRE shall also pay the cost of the audit.

SECTION 20. REGULATIONS, INSPECTION, AND DIRECTIVES

- A. Constitutional and Other Limits on Concessionaire's Rights to Exclusivity:
Notwithstanding exclusivity granted to Concessionaire by the terms of this Agreement, the City in its discretion may require Concessionaire, without any reduction in rent or other valuable consideration to Concessionaire, to accommodate the rights of persons to access and engage in expressive activities, as guaranteed by the first amendment to the United States constitution, the California constitution, and other laws, as these laws are interpreted by the City. Expressive activities include, but are not limited to, protesting, picketing, proselytizing, soliciting, begging, and vending of certain expressive, message-bearing items.
- B. The operations conducted by CONCESSIONAIRE pursuant to the AGREEMENT shall be subject to:
1. Any and all applicable rules, regulations, orders, and restrictions which are now in force or which may be hereafter adopted by CITY with respect to the operation of the CONCESSION;
 2. Any and all orders, directions or conditions issued, given, or imposed by GENERAL MANAGER with respect to the use of the roadways,

driveways, curbs, sidewalks, parking areas, or public areas adjacent to the PREMISES;

3. Any and all applicable laws, ordinances, statutes, rules, regulations or orders, including the LAMC, LAAC, the Charter of City of Los Angeles, and of any governmental authority, federal, state or municipal, lawfully exercising authority over the CONCESSIONAIRE'S operations; and,
4. Any and all applicable local, state and federal laws and regulations relative to the design and installation of facilities to accommodate disabled persons.

C. Permissions:

Any permission required by the AGREEMENT shall be secured in writing by CONCESSIONAIRE from CITY or GENERAL MANAGER and any errors or omissions therefrom shall not relieve CONCESSIONAIRE of its obligations to faithfully perform the conditions therein. CONCESSIONAIRE shall immediately comply with any written request or order submitted to it by CITY or GENERAL MANAGER.

D. Right of Inspection:

CITY and GENERAL MANAGER, their authorized representatives, agents and employees shall have the right to enter upon the PREMISES at any and all reasonable times for the purpose of inspection, evaluation, and observation of CONCESSIONAIRE'S operation. During these inspections, they shall have the right to photograph, film, or otherwise record conditions and events taking place upon the PREMISES. The inspections may be made by persons identified to CONCESSIONAIRE as City Employees, or may be made by independent contractors engaged by CITY. Inspections may be made for the purposes set forth below, and for any other lawful purpose for which the CITY or another governmental entity with jurisdiction is authorized to perform inspections of the PREMISES:

1. To determine if the terms and conditions of the AGREEMENT are being complied with.
2. To observe transactions between the CONCESSIONAIRE and patrons in order to evaluate the quality of services provided or quality and quantities of items sold or dispensed.

E. Control of Premises:

CITY shall have absolute and full access to the PREMISES and all its appurtenances during the term of the AGREEMENT and may make such changes and alterations therein, and in the grounds surrounding same, as may be determined by said CITY. Such determination shall not be unreasonable and

shall take into account the business considerations presented by CONCESSIONAIRE.

- F. Americans with Disabilities Act:
The CONCESSIONAIRE shall comply with the Americans with Disabilities Act 42 U.S.C. Section 12101 et seq., and with the provisions of the Certification Regarding Compliance with the Americans with Disabilities Act which is attached to AGREEMENT and incorporated herein by this reference.
- G. Child Support Ordinance:
The AGREEMENT is subject to Section 10.10, Article 1, Chapter 1, Division 10 of the LAAC, Child Support Assignment Orders Ordinance. CONCESSIONAIRE is required to complete a Certification of Compliance with Child Support obligations which is attached to the AGREEMENT and incorporated herein by this reference. Pursuant to this ordinance, CONCESSIONAIRE shall (1) fully comply with all State and Federal employment reporting requirements applicable to Child Support Assignment Orders; (2) certify that the principal owner(s) of CONCESSIONAIRE are in compliance with any Wage and Earnings Assignment Orders and Notices of Assignment applicable to them personally; (3) fully comply with all lawfully served Wage and Earnings Assignment Orders and Notices of Assignment in accordance with California Family Code section 5230 et seq.; and (4) maintain such compliance throughout the term of this AGREEMENT.
- H. Business Inclusion Program:
CONCESSIONAIRE agrees and obligates itself to utilize the services of Minority, Women, Small, Emerging, Disabled Veteran and Other Business Enterprise firms on a level so designated in its proposal, if any. CONCESSIONAIRE certifies that it has complied with Executive Directive No. 14 regarding the Outreach Program. CONCESSIONAIRE shall not change any of these designated subconsultants and subcontractors, nor shall CONCESSIONAIRE reduce their level of effort, without prior written approval of the CITY, provided that such approval shall not be unreasonably withheld.
- I. Living Wage Ordinance/Service Contract Worker Retention Ordinance:
The CONCESSIONAIRE must comply with City Ordinance 172336 (Living Wage Ordinance), unless exempted in accordance with such ordinance. The Living Wage Ordinance requires in part that nothing less than a prescribed minimum level of compensation (a "living wage") be paid to employees of service contractors of the CITY and its financial assistance recipients and to employees of such recipients. Under Section 10.37.2 of the Ordinance, CONCESSIONAIRE shall pay service employees who spend any of their time on CITY contracts a wage of no less than the hourly rates set under the authority of the Living Wage Ordinance (LWO). Such rates shall be adjusted annually to correspond with adjustments, if any, to retirement benefits paid to members of the Los Angeles City Employees' Retirement System.

CONCESSIONAIRE must also comply with the Service Contract Worker Retention Ordinance (SCWRO), adopted through Ordinance 171004. This Ordinance requires CONCESSIONAIRE to retain all employees from the previous contractor/concessionaire for a period of ninety (90) days, and must continue to retain those satisfactory performing employees.

- J. Contractor Responsibility Ordinance:
Every Request for Proposals, Request for Bid, Request for Qualifications, or other procurement process is subject to the provisions of the Contractor Responsibility Ordinance, Section 10.40 et seq. of Article 14, Chapter 1 of Division 10 of the LAAC, unless exempt pursuant to the provisions of the Ordinance.
- K. Equal Benefits Ordinance:
Section 10.8.2.1 (c) of the LAAC (Equal Benefits Ordinance) requires that every contract with or on behalf of the City of Los Angeles for which the consideration is in excess of the Five Thousand Dollars (\$5,000.00) must incorporate the Equal Benefits Provisions.
- L. Contractor Evaluation Ordinance:
At the end of the AGREEMENT, the CITY will conduct an evaluation of the CONCESSIONAIRE's performance. The CITY may also conduct evaluations of the CONCESSIONAIRE's performance during the term of the AGREEMENT. As required by Section 10.39.2 of the Los Angeles Administrative Code, evaluations will be based on a number of criteria, including the quality of the work product or service performed, the timeliness of performance, financial issues, and the expertise of personnel that the CONCESSIONAIRE assigns to the AGREEMENT. A CONCESSIONAIRE who receives a "Marginal" or "Unsatisfactory" rating will be provided with a copy of the final CITY evaluation and allowed fourteen (14) calendar days to respond. The CITY will use the final CITY evaluation, and any response from the CONCESSIONAIRE, to evaluate proposals and to conduct reference checks when awarding other service contracts.
- M. Slavery Disclosure Ordinance:
Unless otherwise exempt in accordance with the provisions of this Ordinance, the AGREEMENT is subject to the Slavery Disclosure Ordinance, Section 10.41 of the Los Angeles Administrative Code, as may be amended from time to time. CONCESSIONAIRE certifies that it has complied with the applicable provisions of this Ordinance. Failure to fully and accurately complete the affidavit may result in termination of the AGREEMENT.
- N. First Source Hiring Ordinance:
Unless otherwise exempt in accordance with the provisions of this Ordinance, this AGREEMENT is subject to the applicable provisions of the First Source

Hiring Ordinance (FSHO), Section 10.44 et seq. of the LAAC, as amended from time to time.

1. CONCESSIONAIRE shall, prior to the execution of the Agreement, provide to the Designated Administrative Agency (DAA) a list of anticipated employment opportunities that CONCESSIONAIRE estimates it will need to fill in order to perform the services under the AGREEMENT. The Department of Public Works, Bureau of Contract Administration is the DAA.
2. CONCESSIONAIRE further pledges that it will, during the term of the AGREEMENT:
 - a. At least seven business days prior to making an announcement of a specific employment opportunity, provide notifications of that employment opportunity to the Economic and Workforce Development Department (EWDD), which will refer individuals for interview;
 - b. Interview qualified individuals referred by EWDD; and
 - c. Prior to filling any employment opportunity, the CONCESSIONAIRE shall inform the DAA of the names of the Referral Resources used, the names of the individuals they referred, the names of the referred individuals who the CONCESSIONAIRE interviewed and the reasons why referred individuals were not hired.
3. Any Subcontract entered into by the CONCESSIONAIRE relating to this AGREEMENT, to the extent allowed hereunder, shall be subject to the provisions of FSHO, and shall incorporate the FSHO.
4. CONCESSIONAIRE shall comply with all rules, regulations and policies promulgated by the designated administrative agency, which may be amended from time to time.

Where under the provisions of Section 10.44.13 of the LAAC the DAA has determined that the CONCESSIONAIRE intentionally violated or used hiring practices for the purpose of avoiding the article, the determination must be documented in the Awarding Authority's Contractor Evaluation, required under LAAC Section 10.39 et seq., and must be documented in each of the CONCESSIONAIRE's subsequent Contractor Responsibility Questionnaires submitted under LAAC Section 10.40 et seq. This measure does not limit the CITY's authority to act under this article.

Under the provisions of Section 10.44.8 of the LAAC, the Awarding Authority shall, under appropriate circumstances, terminate this AGREEMENT and

otherwise pursue legal remedies that may be available if the DAA determines that the subject CONCESSIONAIRE has violated provisions of the FSHO.

- O. Compliance With Los Angeles City Charter Section 470(c)(12) (Measure H): The CONCESSIONAIRE, Subcontractors, and their Principals are obligated to fully comply with Charter Section 470(c)(12) and related ordinances, regarding limitations on campaign contributions and fundraising for certain elected CITY officials or candidates for elected CITY office if the contract is valued at One Hundred Thousand Dollars (\$100,000.00) or more and requires approval of a CITY elected official. Additionally, CONCESSIONAIRE is required to provide and update certain information to CITY as specified by law. Any CONCESSIONAIRE subject to Charter Section 470(c)(12) shall include the following notice in any contract with a subcontractor expected to receive at least One Hundred Thousand Dollars (\$100,000.00) for performance under this contract:

“Notice Regarding Los Angeles Campaign Contribution and Fundraising Restrictions

As provided in Charter Section 470(c)(12) and related ordinances, you are a subcontractor on City of Los Angeles Concession Agreement No. _____. Pursuant to CITY Charter Section 470(c)(12), subcontractor and its principals are prohibited from making campaign contributions and fundraising for certain elected City officials or candidates for elected City office for 12 months after the City contract is signed. Subcontractor is required to provide to contractor names and addresses of the subcontractor's principals and contact information and shall update that information if it changes during the 12 month time period. Subcontractor's information included must be provided to contractor within 5 business days. Failure to comply may result in termination of contract or any other available legal remedies including fines. Information about the restrictions may be found at the City Ethics Commission's website at <http://ethics.lacity.org/> or by calling (213) 978-1960.”

CONCESSIONAIRE, Subcontractors, and their Principals shall comply with these requirements and limitations. Violation of this provision shall entitle CITY to terminate this AGREEMENT and pursue any and all legal remedies that may be available.

SECTION 21. TERMINATION

- A. By CITY:
CITY shall have the right, via a thirty (30) day written notice, to terminate the AGREEMENT in its entirety and all rights ensuing therefrom as provided by applicable law if any one or more of the following events occur:

1. CONCESSIONAIRE fails to keep, perform and observe any promise, covenant and condition set forth in the AGREEMENT on its part to be kept, performed or observed after receipt of written notice of default from GENERAL MANAGER, except where fulfillment of CONCESSIONAIRE'S obligation requires activity over a period of time and CONCESSIONAIRE has commenced to perform whatever may be required within ten (10) days after receipt of such notice and continues such performance diligently and without interruption except for causes beyond its control;
2. The interest of CONCESSIONAIRE under the AGREEMENT is assigned, transferred, passes to or devolves upon, by operation of law or otherwise, any other person, firm or corporation without the written consent of GENERAL MANAGER;
3. CONCESSIONAIRE becomes, without the prior, written approval of GENERAL MANAGER a successor or merged corporation in a merger, a constituent corporation in a consolidation or a corporation in dissolution;
4. The levy of any attachment or execution, or the appointment of any receiver, or the execution of any other process of any court of competent jurisdiction which is not vacated, dismissed or set aside within a period of ten (10) days and which does, or as a direct consequence of such process will, interfere with CONCESSIONAIRE'S use of the PREMISES or with its operations under the AGREEMENT;
5. CONCESSIONAIRE becomes insolvent, or takes the benefit of any present or future insolvency statute, or makes a general assignment for the benefit of creditors, or files a voluntary petition in bankruptcy, or a petition or answer seeking an arrangement for its reorganization, or the arrangement for its reorganization, or the readjustment of its indebtedness under the federal bankruptcy laws or under any other law or statute of the United States, or of any state law, or consents to the appointment of a receiver, trustee or liquidator of all or substantially all of its property or its property located within the CONCESSION areas;
6. By order or decree of court, CONCESSIONAIRE is adjudged bankrupt, or an order is made approving a petition filed by any of the creditors or stockholders of CONCESSIONAIRE seeking its reorganization or the readjustment of its indebtedness under the federal bankruptcy laws, or under any law or statute of the United States, or any state thereof;
7. A petition under any part of the federal bankruptcy laws, or an action under any present or future solvency law or statute is filed against CONCESSIONAIRE and is not dismissed within one hundred twenty (120) days;

8. By or pursuant to, or under authority of, any legislative act, resolution or rule, order or decree of any court, governmental board, agency or officer having jurisdiction, a receiver, trustee or liquidator takes possession or control of all or substantially all of the property of CONCESSIONAIRE;
9. Cessation or deterioration of service for any period which, in the opinion of GENERAL MANAGER, materially and adversely affects the operation or service required to be performed by CONCESSIONAIRE under the AGREEMENT;
10. Any lien is filed against the PREMISES because of any act or omission of CONCESSIONAIRE and such lien is not removed, enjoined or a bond for satisfaction of such lien is not posted within ten (10) days;
11. CONCESSIONAIRE voluntarily abandons, deserts, vacates or discontinues its operation of the business herein authorized; or
12. CONCESSIONAIRE fails to use the PREMISES or any substantial portion thereof for a period of thirty (30) consecutive days unless CONCESSIONAIRE, prior to the expiration of any such period of thirty (30) consecutive days, notifies GENERAL MANAGER in writing such that non-use is temporary and obtains written consent of GENERAL MANAGER to such non-use.

No acceptance by CITY of the revenue-sharing payment or other payments specified herein, in whole or in part, and for any period, after a default of any of the terms, covenants and conditions to be performed, kept or observed by CONCESSIONAIRE, other than the default in the payment thereof, shall be deemed a waiver of any right on the part of CITY including the right to terminate the AGREEMENT on account of such default.

- B. CITY'S Right of Re-entry:
CITY shall, as an additional remedy, upon the giving of written notice of termination as above provided, have the right to reenter the PREMISES and every part thereof on the effective date of termination without further notice of any kind, remove any and all persons therefrom and may regain and resume possession either with or without the institution of summary or legal proceedings or otherwise. Such reentry, however, shall not in any manner affect, alter or diminish any of the obligations of the CONCESSIONAIRE under the AGREEMENT.
- C. Additional Rights of CITY:
CITY, upon termination of the AGREEMENT, or upon reentry, regaining, or resumption of possession of the PREMISES, may occupy said PREMISES and shall have the right to permit any person, firm or corporation to enter upon the PREMISES and use the same. Such occupation by others may be of only a part

of the PREMISES, or the whole thereof or a part thereof together with other space, and for a period of time the same as or different from the balance of the term remaining hereunder, and on terms and conditions the same as or different from those set forth in the AGREEMENT.

D. Survival of CONCESSIONAIRE'S Obligations:

In the event the AGREEMENT is terminated by CITY, or in the event CITY reenters, regains, or resumes possession of the PREMISES, all of the obligations of CONCESSIONAIRE hereunder shall survive and shall remain in full force and effect for the full term of the AGREEMENT. Subject to CITY'S obligation to mitigate damages, the amount of the revenue-sharing payment shall become due and payable to CITY to the same extent, at the same time and in the same manner as if no termination, reentry, regaining or resumption of possession had taken place. CITY may maintain separate actions to recover any monies then due, or at its option and at any time, may sue to recover the full deficiency.

The amount of damages for the period of time subsequent to termination, reentry, regaining or resumption of possession, subject to an offset for any revenue-sharing payment received by CITY from a succeeding CONCESSIONAIRE, shall be the amount of revenue-sharing otherwise due until the end of the term of the AGREEMENT.

The damages specified above shall not affect or be construed to affect CITY'S right to such damages in the event of termination, reentry, regaining or resumption of possession where CONCESSIONAIRE has not received any actual gross receipts under the AGREEMENT.

E. Waiver of Redemption and Damages:

CONCESSIONAIRE hereby waives any and all rights of redemption granted by or under any present or future law or statute in the event it is dispossessed for any cause, or in the event CITY obtains or retains possession of the PREMISES in any lawful manner. CONCESSIONAIRE further agrees that in the event the manner or method employed by CITY in reentering or regaining possession of the PREMISES gives rise to a cause of action in CONCESSIONAIRE in forcible entry and detailed under the laws of the State of California, the total amount of damages to which CONCESSIONAIRE shall be entitled in any such action shall be the sum of One Dollar (\$1.00), and CONCESSIONAIRE agrees that this provision may be filed in any such action as its stipulation fixing the amount of damages to which it is entitled.

F. By CONCESSIONAIRE:

The AGREEMENT may be terminated by CONCESSIONAIRE, via a thirty (30)-day written notice, upon the occurrence of one or more of the following events:

1. The permanent abandonment by DEPARTMENT of the FACILITY or the permanent removal of all DEPARTMENT services from the FACILITY;

2. The lawful assumption by the United States Government, or any authorized agency thereof, of the operation, control or use of the FACILITY or any substantial part thereof, in such manner as to materially restrict CONCESSIONAIRE from operating thereon;
3. The complete destruction of all or a substantial portion of the PREMISES from a cause other than the negligence or omission to act of CONCESSIONAIRE, its agents, officers, or employees, and the failure of CITY to repair or reconstruct said PREMISES;
4. Any exercise of authority under the AGREEMENT which so interferes with CONCESSIONAIRE'S use and enjoyment of the PREMISES as to constitute a termination, in whole or in part, of the AGREEMENT by operation of law in accordance with the laws of the State of California; or
5. The default by CITY in the performance of any covenant or agreement herein required to be performed by CITY and the failure of CITY to remedy such default for a period of thirty (30) days after receipt from CONCESSIONAIRE of written notice to do so.

SECTION 22. SURRENDER OF POSSESSION

CONCESSIONAIRE agrees to yield and deliver possession of the PREMISES to CITY on the date of the expiration or earlier termination of the AGREEMENT promptly, peaceably, quietly, and in as good order and condition as the same now are or may be hereafter improved by CONCESSIONAIRE or CITY, normal use and wear and tear thereof excepted.

No agreement of surrender or to accept a surrender shall be valid unless and until the same is in writing and signed by the duly authorized representatives of CITY and CONCESSIONAIRE. Neither the doing nor omission of any act or thing by any of the officers, agents or employees of CITY shall be deemed an acceptance of a surrender of the PREMISES utilized by CONCESSIONAIRE under the AGREEMENT.

Upon termination of this AGREEMENT other than by forfeiture, CONCESSIONAIRE shall quit and surrender possession of the PREMISES to CITY and shall, without cost to CITY, remove any and all works, structures, or other improvements owned by CONCESSIONAIRE and restore the premises to the same or as good condition, ordinary wear and tear excepted, as the same were in it at the time of the first occupancy, thereof by CONCESSIONAIRE under this or any prior agreement or lease. CONCESSIONAIRE will have thirty (30) days to effect removal and restoration. GENERAL MANAGER may at his option accept all or a portion of the works, structures, or other improvements on behalf of CITY in lieu of all or a portion of the removal or restoration required herein.

SECTION 23. WAIVER

A waiver of a default of any part, term, or provision of the AGREEMENT shall not be construed as a waiver of any succeeding default or as a waiver of the part, term, or provision itself. A party's performance after the other party's default shall not be construed as a waiver of that default.

SECTION 24. CONDITIONS AND COVENANTS

Each covenant herein is a condition, and each condition herein is as well a covenant by the parties bound thereby, unless waived in writing by the parties hereto.

SECTION 25. FORCE MAJEURE

Neither party hereto shall be liable to the other for any failure, delay, or interruption in the performance of any of the terms, covenants or conditions of the AGREEMENT due to causes beyond the control of that party including, without limitation, strikes, boycotts, labor disputes, embargoes, shortage of material, acts of God, landslides, acts of the public enemy, acts of superior governmental authority, floods, fires, riots, rebellion, sabotage, or any other circumstance for which such party is not responsible and which is not in its power to control.

SECTION 26. REMEDIES ARE NON-EXCLUSIVE

No right, power, remedy, or privilege of CITY shall be construed as being exhausted or discharged by the exercise thereof in one or more instances. It is agreed that each and all of said rights, powers, remedies, or privileges shall be deemed cumulative and additional and not in lieu or exclusive of each other or of any other remedy available to CITY at law or in equity.

SECTION 27. AGREEMENT BINDING UPON SUCCESSORS

The AGREEMENT shall be binding upon and shall inure to the benefit of the successors, heirs, executors, administrators, and assigns of the parties hereto. The term "CONCESSIONAIRE" shall include any assignee of CONCESSIONAIRE under any assignment permitted and approved by GENERAL MANAGER.

SECTION 28. LAW OF CALIFORNIA APPLIES

The AGREEMENT shall be enforced and interpreted under the laws of the State of California.

SECTION 29. AGENT FOR SERVICE OF PROCESS

It is expressly agreed and understood that if CONCESSIONAIRE is not a resident of the State of California, or is a partnership or joint venture without a partner or member

resident in said State, or is a foreign corporation, then in any such event CONCESSIONAIRE does designate the Secretary of State, State of California, its agent for the purpose of service of process in any court action between it and CITY arising out of or based upon the AGREEMENT, and the service shall be made as provided by the laws of the State of California for service upon a non-resident. It is further expressly agreed, covenanted and stipulated that if, for any reason, service of such process is not possible, as an alternative method of service of process, CONCESSIONAIRE may be personally served with such process out of this State by mailing, by registered or certified mail, the complaint and process to CONCESSIONAIRE at the address set out hereafter in the AGREEMENT, and that such service shall constitute valid service upon CONCESSIONAIRE as of the date of mailing, and CONCESSIONAIRE shall have thirty (30) days from the date of mailing to respond thereto. It is further expressly agreed that CONCESSIONAIRE is amenable, and hereby agrees, to the process so served, submits to the jurisdiction and waives any and all objection and protest thereto, any laws to the contrary notwithstanding.

SECTION 30. VENUE

Venue of any action brought under the AGREEMENT shall lie in Los Angeles County.

SECTION 31. WAIVER OF CLAIMS

CONCESSIONAIRE hereby waives any claim against CITY, its officers, agents, or employees, for loss of anticipated profits caused by any suit or proceeding directly or indirectly attacking the validity of the AGREEMENT or any part hereof, or by any judgment or award in any suit or proceeding declaring the AGREEMENT null, void or voidable, or delaying the same, or any part hereof, from being carried out.

SECTION 32. NOTICES

A. To CITY:

Unless otherwise stated in the AGREEMENT, written notices to CITY hereunder shall be addressed to:

Department of Recreation and Parks
Attention: Partnership and Revenue Branch/Concessions Unit
P. O. Box 86610
Los Angeles, California 90086-0610

All such notices may either be delivered personally or may be deposited in the United States mail, properly addressed as aforesaid with postage fully prepaid for delivery by registered or certified mail. Service in such manner by registered or certified mail shall be effective upon receipt.

CITY shall provide CONCESSIONAIRE with written notice of any address change within thirty (30) days of the occurrence of said change.

B. To CONCESSIONAIRE:

The execution of any notice to CONCESSIONAIRE by GENERAL MANAGER shall be as effective for CONCESSIONAIRE as if it were executed by BOARD, or by Resolution or Order of said BOARD.

All such notices may either be delivered personally to the CONCESSIONAIRE or to any officer or responsible employee of CONCESSIONAIRE or may be deposited in the United States mail, properly addressed as aforesaid with postage fully prepaid for delivery by registered or certified mail. Service in such manner by registered or certified mail shall be effective upon receipt.

C. Written notices to CONCESSIONAIRE shall be addressed to CONCESSIONAIRE as follows:

*CONCESSIONAIRE NAME
Attention: CONCESSION MANAGER
STREET ADDRESS
CITY, STATE ZIP*

CONCESSIONAIRE shall provide CITY with written notice of any address change within thirty (30) days of the occurrence of said address change.

SECTION 33. INTERPRETATION

The language of the AGREEMENT shall be construed according to its fair meaning and not strictly for or against either CITY or CONCESSIONAIRE.

The section headings appearing herein are for the convenience of CITY and CONCESSIONAIRE, and shall not be deemed to govern, limit, modify or in any manner affect the scope, meaning or intent of the provisions of the AGREEMENT.

If any provision of the AGREEMENT is determined to be void by any court of competent jurisdiction, then such determination shall not affect any other provision of the AGREEMENT, and all such other provisions shall remain in full force and effect; and it is the intention of the parties hereto that if any provision of the AGREEMENT is capable of two constructions, one of which render the provision void and the other of which would render the provision valid, then the provision shall have the meaning which renders it valid.

The use of any gender herein shall include all genders and the use of any number shall be construed as the singular or the plural, all as the context may require.

SECTION 34. AGREEMENT CONTAINS ENTIRE AGREEMENT

The provisions of the AGREEMENT contain the entire AGREEMENT between the parties hereto and said AGREEMENT may not be changed or modified in any manner

except by formal, written amendment fully executed by both CITY and CONCESSIONAIRE.

SECTION 35. TIME OF THE ESSENCE

Time is of the essence for all provisions of the AGREEMENT.

SECTION 36. ACCEPTANCE OF PREMISES

CONCESSIONAIRE has inspected the PREMISES and agrees that they are suitable for the uses permitted herein. No officer or employee of CITY has made any representation or warranty with respect to the PREMISES except as described in writing.

SECTION 37. INCORPORATION OF DOCUMENTS

This AGREEMENT and incorporated documents represent the entire integrated agreement of the parties and supersedes all prior written or oral representations, discussions, and agreements. The following Exhibits are to be attached to and made part of this AGREEMENT by reference:

- A. Greek Theatre Premises Map
- B. Proposal in Response to RFP No. CON-XXX-XXX
- C. Remittance Advice Form
- D. Insurance Requirements Form
- E. Form General No. 87 "Non-Employee Accident or Illness Report"
- F. Special Occurrence and Loss Report
- G. Standard Provisions for City Contracts (Rev. 3/09)

In the event of any inconsistency between any of the provisions of this AGREEMENT and/or exhibits attached hereto, the inconsistency shall be resolved by giving precedence in the following order: 1) This AGREEMENT exclusive of attachments, 2) Exhibit A, 3) Exhibit B, 4) Exhibit C, 5) Exhibit D, 6) Exhibit E, 7) Exhibit F, and Exhibit G.

(Signature Page to Follow)

IN WITNESS WHEREOF, THE CITY OF LOS ANGELES has caused this AGREEMENT to be executed on its behalf by its duly authorized Board of Recreation and Park Commissioners, and CONCESSIONAIRE has executed the same as of the day and year herein below written.

THE CITY OF LOS ANGELES, a municipal corporation, acting by and through its BOARD OF RECREATION AND PARK COMMISSIONERS

BY: _____

President

DATE: _____

BY: _____

Secretary

DATE: _____

CONCESSIONAIRE NAME

BY: _____

DATE: _____

Title: _____

BTRC: _____

APPROVED AS TO FORM:
MICHAEL N. FEUER, City Attorney

BY: _____

Deputy City Attorney

DATE: _____

Concession Agreement Number: _____

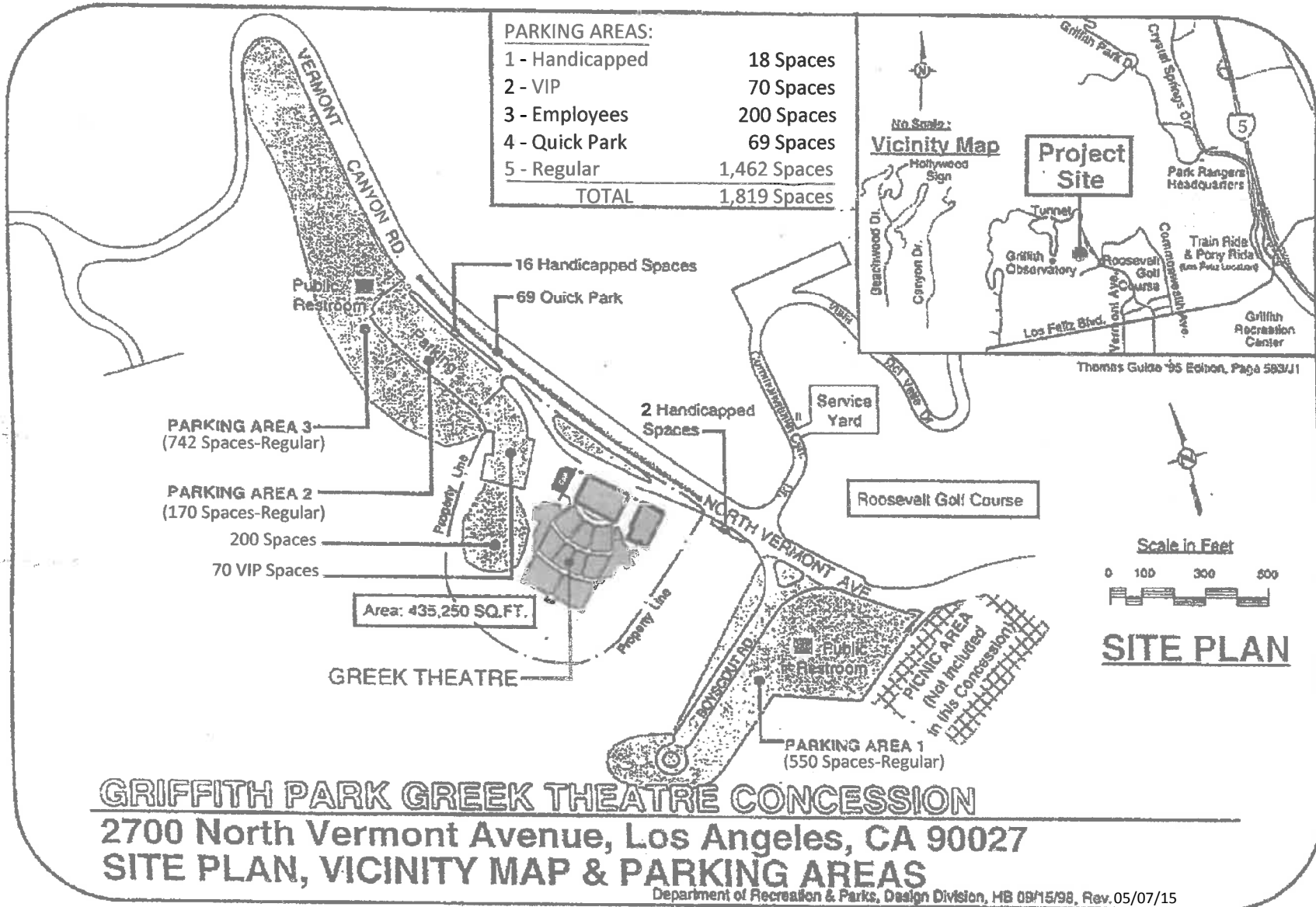

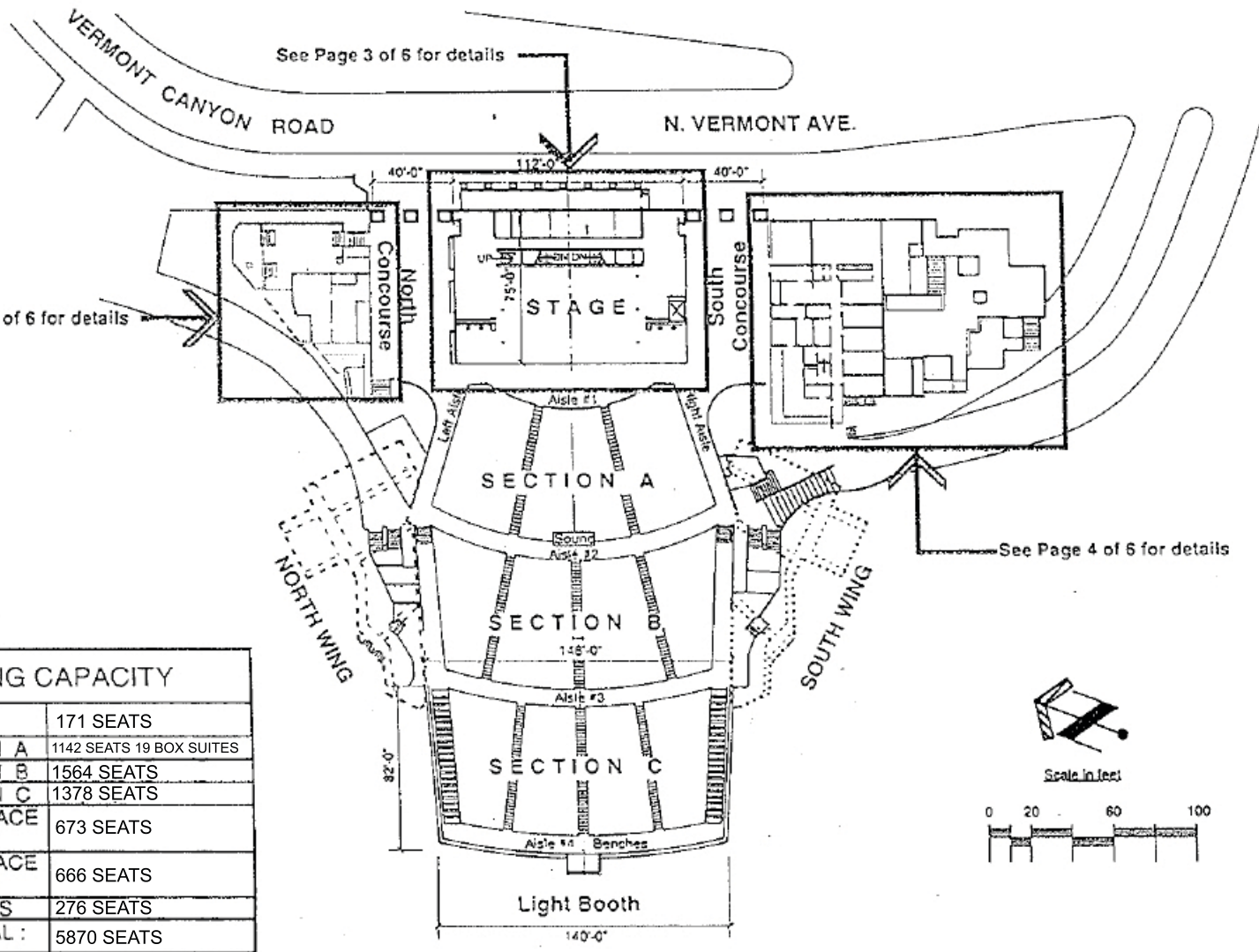

SEATING CAPACITY	
PIT	171 SEATS
SECTION A	1142 SEATS 19 BOX SUITES
SECTION B	1564 SEATS
SECTION C	1378 SEATS
N. TERRACE (N. Wing)	673 SEATS
S. TERRACE (S. Wing)	666 SEATS
BENCHES	276 SEATS
TOTAL :	5870 SEATS

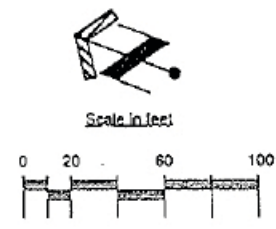

GRIFFITH PARK GREEK THEATRE CONCESSION
 2700 North Vermont Avenue, Los Angeles, CA 90027
FIRST FLOOR PLAN

North
Concourse

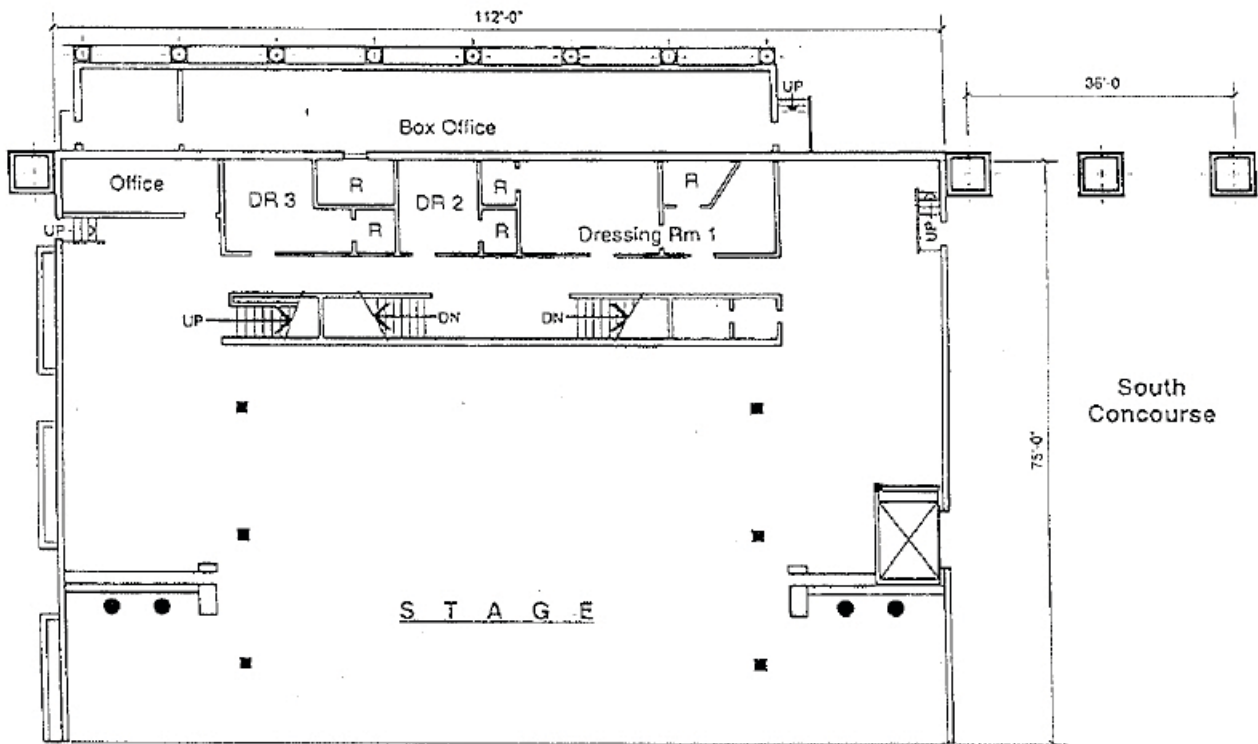

South
Concourse

S T A G E

FIRST FLOOR

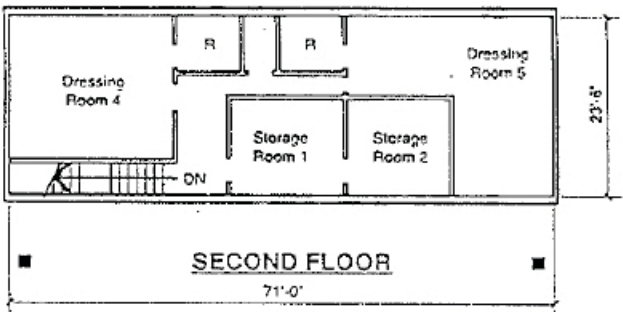

SECOND FLOOR

Scale in Feet

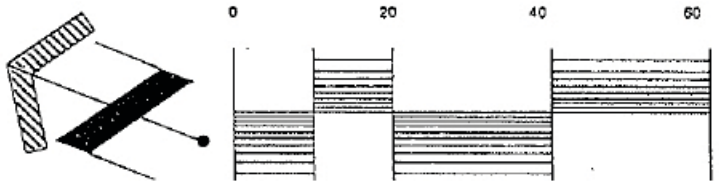

GRIFFITH PARK GREEK THEATRE CONCESSION
 2700 North Vermont Avenue, Los Angeles, CA 90027
FIRST FLOOR (STAGE) AND SECOND FLOOR

**SOUTH
CONCOURSE**

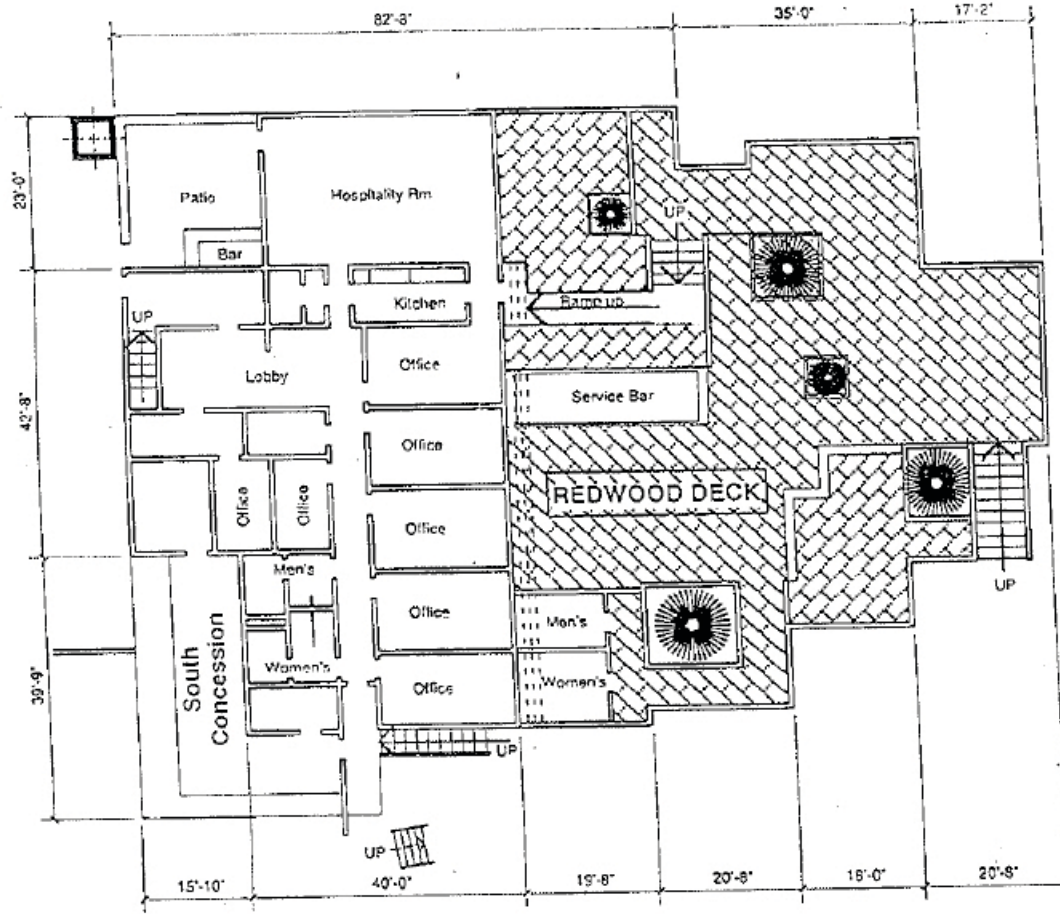

Scale in Feet

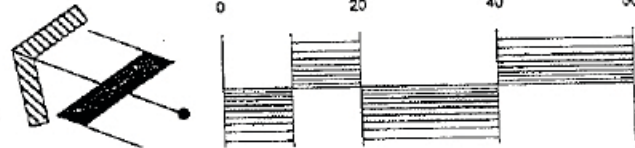

GRIFFITH PARK GREEK THEATRE CONCESSION
 2700 North Vermont Avenue, Los Angeles, CA 90027
FIRST FLOOR / SOUTH WING

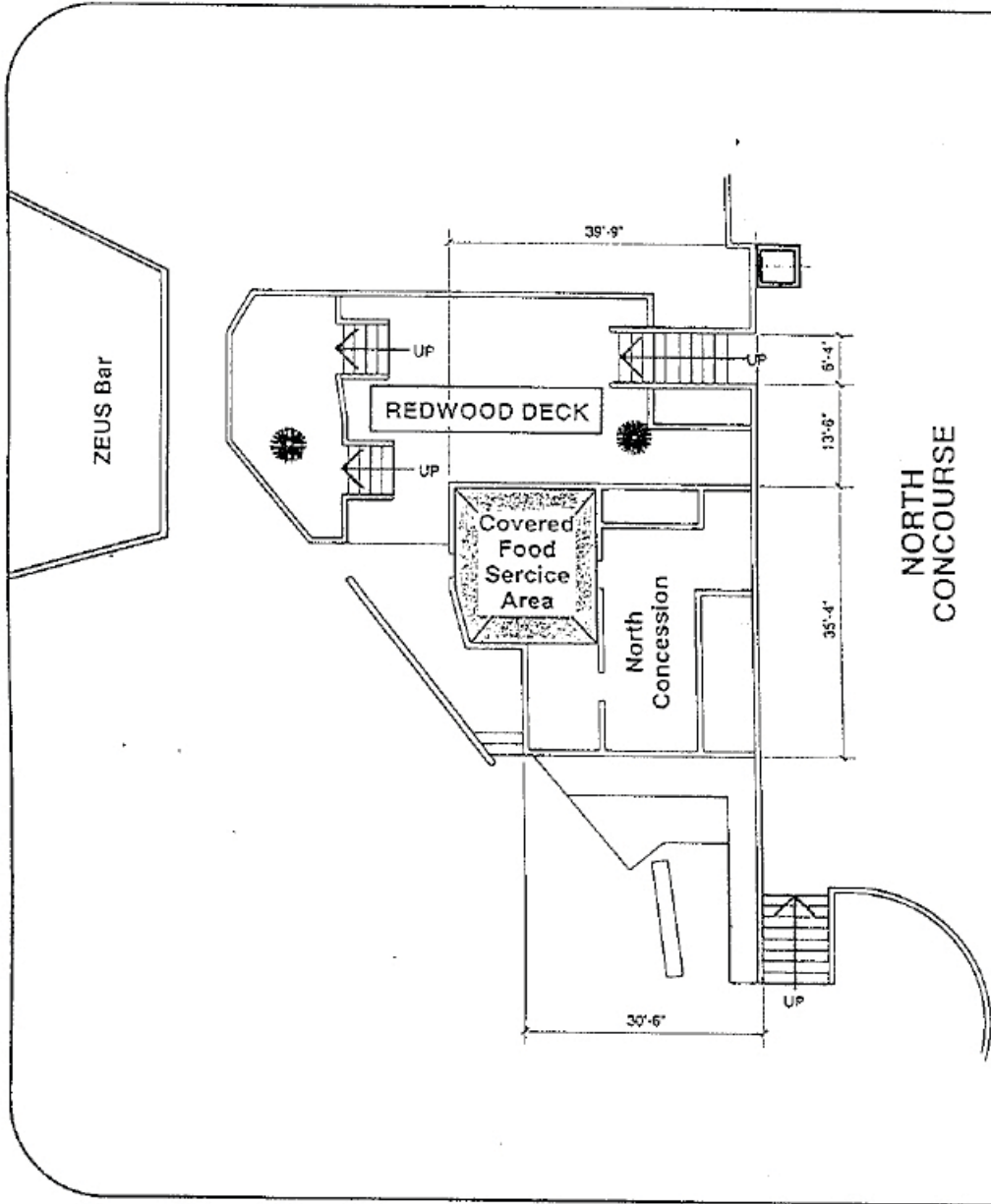

NORTH
CONCOURSE

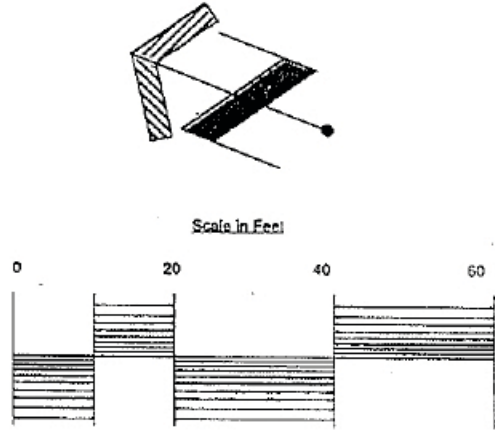

GRIFFITH PARK GREEK THEATRE CONCESSION
 2700 North Vermont Avenue, Los Angeles, CA 90027
FIRST FLOOR / NORTH WING

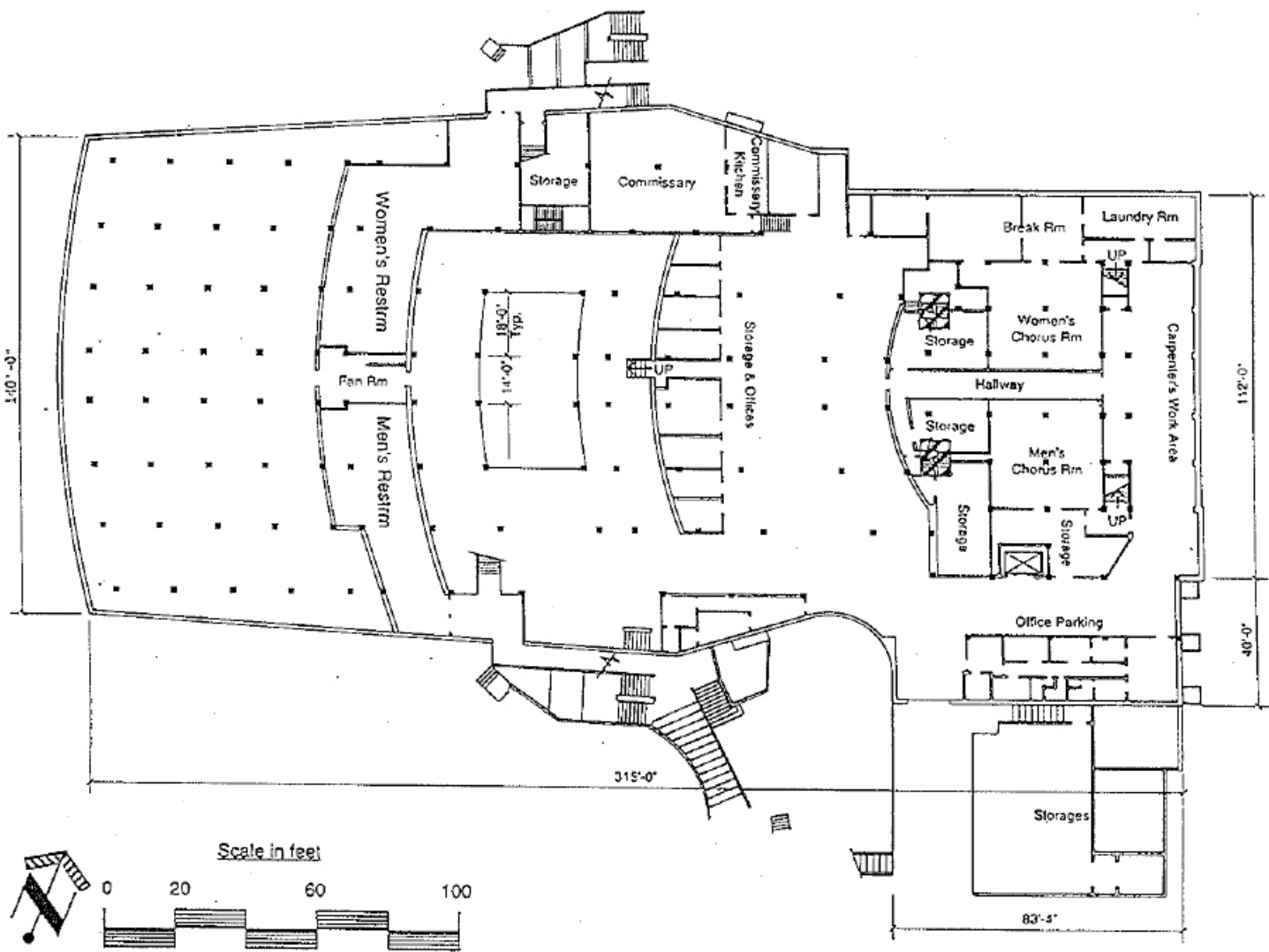

GRIFFITH PARK GREEK THEATRE CONCESSION
2700 North Vermont Avenue, Los Angeles, CA 90027
BASEMENT PLAN

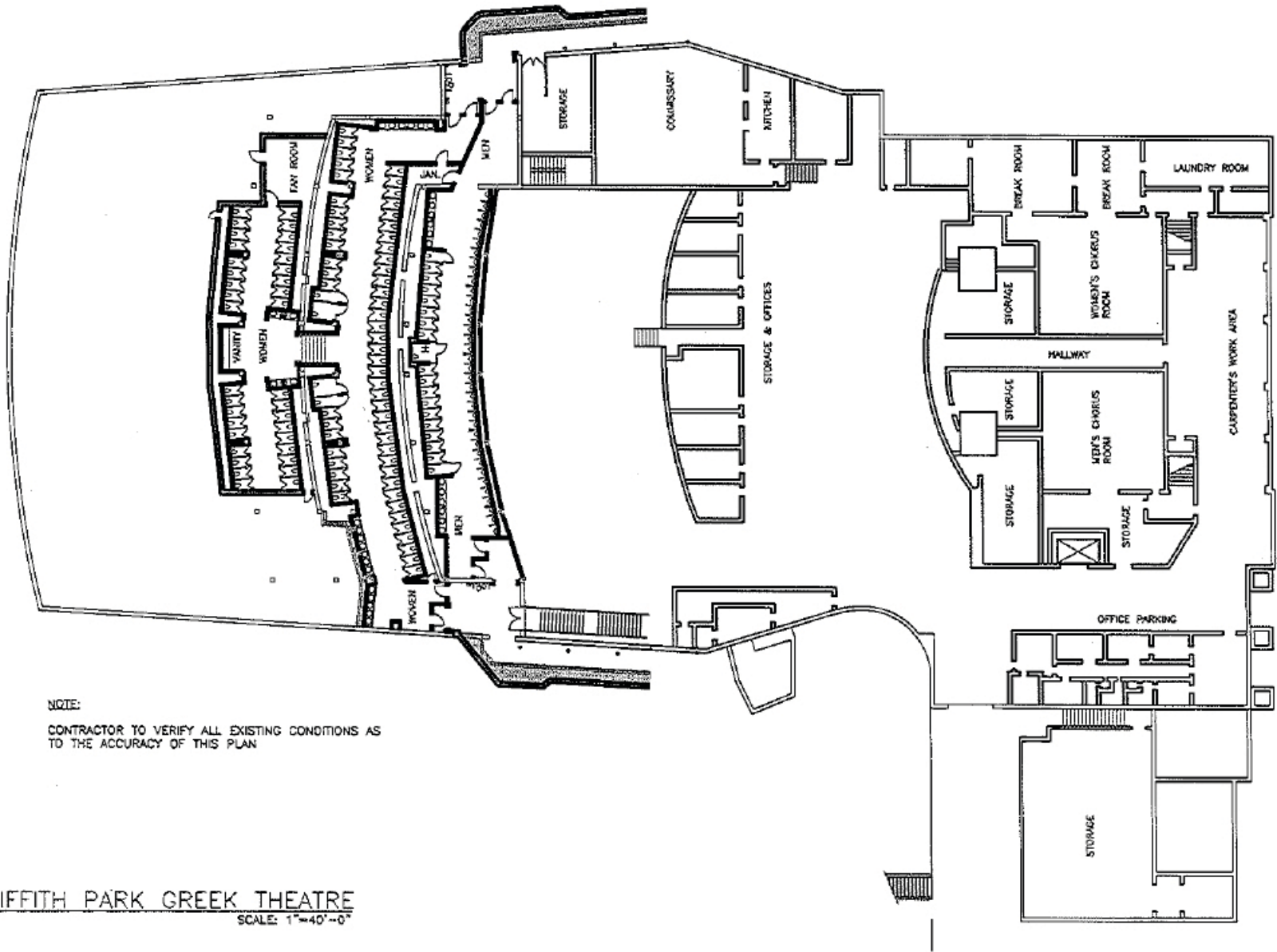

NOTE:

CONTRACTOR TO VERIFY ALL EXISTING CONDITIONS AS TO THE ACCURACY OF THIS PLAN

GRIFFITH PARK GREEK THEATRE
SCALE: 1"=40'-0"

PROJECT NO.	SHEET TITLE NEW RESTROOM FLOORPLAN	GENERAL MANAGER	DESIGN/DATE	DELTA	REVISIONS	BY	DATE	
FILE NO.	PROJECT GRIFFITH PARK GREEK THEATRE CONCESSION	DIRECTOR OF PLANNING & CONSTRUCTION	DRAWN/DATE				05/20/14	
SHEET NO.	FACILITY ADDRESS 2700 NORTH VERMONT AVE. L.A., CA 90027	CONTRACT ADMINISTRATOR	CHECK/DATE					

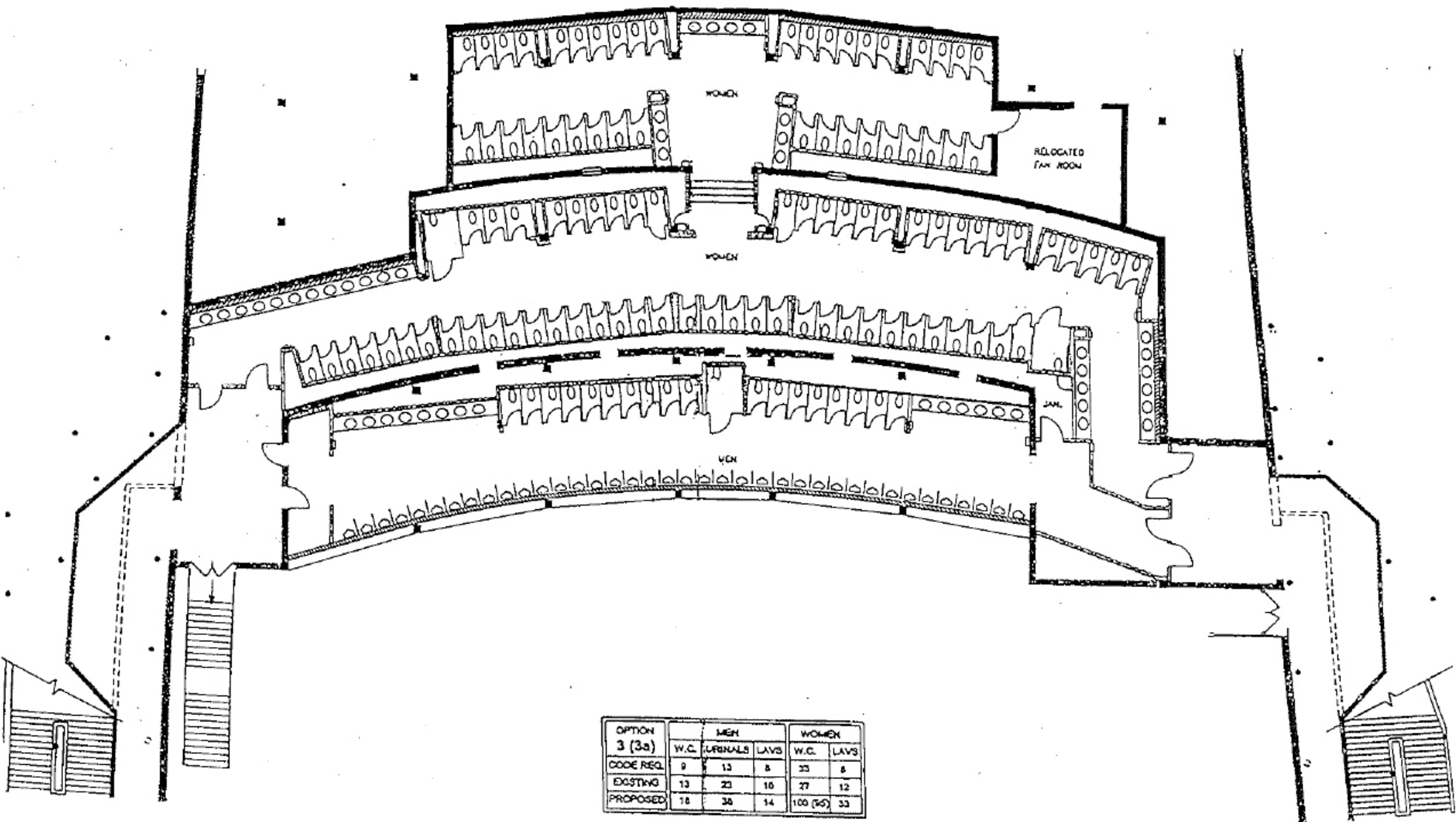

OPTION 3 (3a)	MEN			WOMEN	
	W.C.	URINALS	LAVS	W.C.	LAVS
CODE REQ.	9	13	8	23	8
EXISTING	13	23	10	27	12
PROPOSED	18	38	14	100 (50)	33

GRIFFITH PARK GREEK THEATRE CONCESSION
 2700 North Vermont Avenue, Los Angeles, CA 90027
MEN'S & WOMEN'S RESTROOMS

Rev 05/20/14

Exhibit B of Concession Agreement

Proposal in Response to
RFP No. CON-XXX-XXX
With Good Food Policy Pledge

(to be submitted by Proposer)

**CITY OF LOS ANGELES
DEPARTMENT OF RECREATION AND PARKS
Attn: Concessions Unit
P.O. Box 86610
Los Angeles, CA 90086**

**REMITTANCE ADVICE FORM
GREEK THEATRE FOOD AND BEVERAGE CONCESSION
NAME OF CONCESSIONAIRE**

PERIOD COVERED: From: _____ To: _____

CATEGORY	GROSS SALES	SALES TAX	NET SALES	RENTAL RATE	AMOUNT DUE
FOOD:	_____	_____	_____	XX%	#VALUE!
BEVERAGES:	_____	_____	_____	XX%	#VALUE!
OTHER:	_____	_____	_____	XX%	#VALUE!
SUB-TOTAL RENT DUE:					<u>#VALUE!</u>

UTILITIES: \$ 800.00 _____

LATE RENT FEE: All payments are due by the 15th for the previous month.
\$ -

OCCUPANCY TAX: Paid Quarterly (April / July / October / January) for preceeding three months at \$1.48 per \$1,000 or fraction thereof of rent paid
\$ -

LATE OCCUPANCY TAX FEE: Occupancy Tax payments are due quarterly by the 15th of April, July, October, January for the preceding three (3) months.
\$ -

SUB-TOTAL DUE: #VALUE!

ADJUSTMENTS*: Explain:

_____ \$ -

*NOTE: All amortizations (allowance for rent reduction for any expenditure) must be approved in writing by the Department of Recreation and Parks. Invoices and proof of payment must be submitted with the Remittance Advice for any and all months amortization is realized.

TOTAL AMOUNT DUE: #VALUE!

I hereby certify that this is a true and correct record of the period stated above:

Signature: _____ Date: _____

Required Insurance and Minimum Limits

Name: Greek Theatre Food & Beverage Concession RFP

Date: 04/08/2015

Agreement/Reference: _____

Evidence of coverages checked below, with the specified minimum limits, must be submitted and approved prior to occupancy/start of operations. Amounts shown are Combined Single Limits ("CSLs"). For Automobile Liability, split limits may be substituted for a CSL if the total per occurrence equals or exceeds the CSL amount.

Limits

Workers' Compensation - Workers' Compensation (WC) and Employer's Liability (EL)

WC Statutory

EL \$1,000,000

Waiver of Subrogation in favor of City

Longshore & Harbor Workers

Jones Act

General Liability _____ \$5,000,000

Products/Completed Operations

Sexual Misconduct _____

Fire Legal Liability \$100,000 _____

Liquor Liability \$1,000,000 _____

Rental Interruption 180 days

Automobile Liability (for any and all vehicles used for this contract, other than commuting to/from work) \$1,000,000

____ **Professional Liability** (Errors and Omissions) _____

Discovery Period 12 Months After Completion of Work or Date of Termination

____ **Property Insurance** (to cover replacement cost of building - as determined by insurance company) _____

All Risk Coverage

Boiler and Machinery

Flood _____

Builder's Risk

Earthquake _____

____ **Pollution Liability** _____

____ **Surety Bonds - Performance and Payment (Labor and Materials) Bonds** 100% of the contract price

____ **Crime Insurance** _____

Other: _____

CITY OF LOS ANGELES

INSTRUCTIONS AND INFORMATION
ON COMPLYING WITH CITY INSURANCE REQUIREMENTS

(Share this information with your insurance agent or broker)

1. **Agreement/Reference** All evidence of insurance must identify the nature of your business with the CITY. Clearly show any assigned number of a bid, contract, lease, permit, etc. or give the project name and the job site or street address to ensure that your submission will be properly credited. Provide the **types of coverage and minimum dollar amounts** specified on the Required Insurance and Minimum Limits sheet (Form Gen. 146) included in your CITY documents.

2. **When to submit** Normally, no work may begin until a CITY insurance certificate approval number ("CA number") has been obtained, so insurance documents should be submitted as early as practicable. For **As-needed Contracts**, insurance need not be submitted until a specific job has been awarded. **Design Professionals** coverage for new construction work may be submitted simultaneously with final plans and drawings, but before construction commences.

3. **Acceptable Evidence and Approval** Electronic submission is the best method of submitting your documents. **Track4LA**[®] is the CITY's online insurance compliance system and is designed to make the experience of submitting and retrieving insurance information quick and easy. The system is designed to be used by insurance brokers and agents as they submit client insurance certificates directly to the City. It uses the standard insurance industry form known as the **ACORD 25 Certificate of Liability Insurance** in electronic format – the CITY is a licensed redistributor of ACORD forms. Track4LA[®] advantages include standardized, universally accepted forms, paperless approval transactions (24 hours, 7 days per week), and security checks and balances. The easiest and quickest way to obtain approval of your insurance is to have your insurance broker or agent access **Track4LA**[®] at <http://track4la.lacity.org> and follow the instructions to register and submit the appropriate proof of insurance on your behalf.

Insurance industry certificates other than the ACORD 25 that have been approved by the State of California may be accepted, however ***submissions other than through Track4LA[®] will significantly delay the insurance approval process as documents will have to be manually processed.*** All Certificates must provide a thirty (30) days' cancellation notice provision (ten (10) days for non-payment of premium) AND an Additional Insured Endorsement naming the CITY an additional insured completed by your insurance company or its designee. If the policy includes an automatic or blanket additional insured endorsement, the Certificate must state the CITY is an automatic or blanket additional insured. An endorsement naming the CITY an Additional Named Insured and Loss Payee as Its Interests May Appear is required on property policies. All evidence of insurance must be authorized by a person with authority to bind coverage, whether that is the authorized agent/broker or insurance underwriter. Completed **Insurance Industry Certificates other than ACORD 25 Certificates** are sent electronically to CAO.insurance.bonds@lacity.org.

Additional Insured Endorsements DO NOT apply to the following:

- Indication of compliance with statute, such as Workers' Compensation Law.
- Professional Liability insurance.

Verification of approved insurance and bonds may be obtained by checking **Track4LA**[®], the CITY's online insurance compliance system, at <http://track4la.lacity.org>.

4. **Renewal** When an existing policy is renewed, have your insurance broker or agent submit a new Acord 25 Certificate or edit the existing Acord 25 Certificate through **Track4LA**[®] at <http://track4la.lacity.org>.

5. **Alternative Programs/Self-Insurance** Risk financing mechanisms such as Risk Retention Groups, Risk Purchasing Groups, off-shore carriers, captive insurance programs and self-insurance programs are subject to separate approval after the CITY has reviewed the relevant audited financial statements. To initiate a review of your program, you should complete the Applicant's Declaration of Self Insurance form (<http://cao.lacity.org/risk/InsuranceForms.htm>) to the Office of the City Administrative Officer, Risk Management for consideration.

6. **General Liability** insurance covering your operations (and products, where applicable) is required whenever the CITY is at risk of third-party claims which may arise out of your work or your presence or special event on City premises. **Sexual Misconduct** coverage is a required coverage when the work performed involves minors. **Fire Legal Liability** is required for persons occupying a portion of CITY premises. Information on two CITY insurance programs, the SPARTA program, an optional source of low-cost insurance which meets the most minimum requirements, and the Special Events Liability Insurance Program, which provides liability coverage for short-term special events on CITY premises or streets, is available at (www.2sparta.com), or by calling (800) 420-0555.

7. **Automobile Liability** insurance is required only when vehicles are used in performing the work of your Contract or when they are driven off-road on CITY premises; it is not required for simple commuting unless CITY is paying mileage. However, compliance with California law requiring auto liability insurance is a contractual requirement.

8. **Errors and Omissions** coverage will be specified on a project-by-project basis if you are working as a licensed or other professional. The length of the claims discovery period required will vary with the circumstances of the individual job.

9. **Workers' Compensation and Employer's Liability** insurance are not required for single-person contractors. However, under state law these coverages (or a copy of the state's Consent To Self Insure) must be provided if you have any employees at any time during the period of this contract. Contractors with no employees must complete a Request for Waiver of Workers' Compensation Insurance Requirement (<http://cao.lacity.org/risk/InsuranceForms.htm>). **A Waiver of Subrogation** on the coverage is required only for jobs where your employees are working on CITY premises under hazardous conditions, e.g., uneven terrain, scaffolding, caustic chemicals, toxic materials, power tools, etc. The Waiver of Subrogation waives the insurer's right to recover (from the CITY) any workers' compensation paid to an injured employee of the contractor.

10. **Property Insurance** is required for persons having exclusive use of premises or equipment owned or controlled by the CITY. **Builder's Risk/Course of Construction** is required during construction projects and should include building materials in transit and stored at the project site.

11. **Surety** coverage may be required to guarantee performance of work and payment to vendors and suppliers. A **Crime Policy** may be required to handle CITY funds or securities, and under certain other conditions. **Specialty coverages** may be needed for certain operations. For assistance in obtaining the CITY required bid, performance and payment surety bonds, please see the City of Los Angeles Bond Assistance Program website address at <http://cao.lacity.org/risk/BondAssistanceProgram.pdf> or call (213) 258-3000 for more information.

City of Los Angeles

ORIG.—City Attorney
 DUP.—Safety Engineer
 TRIP.—Department

NON-EMPLOYEE ACCIDENT OR ILLNESS REPORT

DEPARTMENT REPORTING

INSTRUCTIONS: All accidents, illnesses or injuries, no matter how minor, involving non-employees while on City property, must be reported by the City employee or department in proximity. Be complete as possible. The information provided may be needed by the City Attorney in preparing the case if legal action is necessary. Use typewriter or print carefully.

PART I — PERSONAL DATA

1. NAME (OF PERSON INJURED) (Last) (First) (MI)			2a. HOME ADDRESS (Street) (City) (Zone)			3a. PHONE NO.
			2b. BUSINESS ADDRESS (Street) (City) (Zone)			3b. PHONE NO.
4. SEX <input type="checkbox"/> M <input type="checkbox"/> F	5. DATE OF BIRTH		6. IF MINOR, NAME OF PARENT OR GUARDIAN			7. PHONE NO.

PART II — ACCIDENT/INJURY

8. DATE	9. TIME A.M. P.M.		10. LOCATION OF PUBLIC PROPERTY INVOLVED			11. WAS FIRST AID GIVEN? <input type="checkbox"/> YES <input type="checkbox"/> NO	
12. FIRST AID GIVEN BY (NAME)			(ADDRESS)			(PHONE NO.)	
13. PHYSICIAN/HOSPITAL INJURED TAKEN TO			(ADDRESS)			(PHONE NO.)	
14. NATURE OF INJURIES (BE SPECIFIC)							
15. DESCRIBE ACCIDENT (IN DETAIL)							
16. NAME AND POSITION OF PERSON IMMEDIATELY IN CHARGE OF FACILITY				17. WHERE WAS RESPONSIBLE PERSON AT TIME OF ACCIDENT?			

PART III — WITNESSES

18. NAME (Last) (First) (MI)	19. ADDRESS (Street) (City) (Zone)	20. PHONE NO.	CITY EMPLOYEE <input type="checkbox"/> YES <input type="checkbox"/> NO
a.			<input type="checkbox"/> YES <input type="checkbox"/> NO
b.			<input type="checkbox"/> YES <input type="checkbox"/> NO
c.			<input type="checkbox"/> YES <input type="checkbox"/> NO
d.			<input type="checkbox"/> YES <input type="checkbox"/> NO

PART IV — STATEMENT OF INJURED PARTY OR WITNESS

21.

PART V — EMPLOYEE FILING REPORT

22. NAME AND POSITION	23. SIGNATURE	24. DATE
-----------------------	---------------	----------

SPECIAL OCCURRENCE AND LOSS REPORT

REPORT NUMBER

SEE INSTRUCTIONS ON PAGE 2

1. NAME OF FACILITY					DATE OF OCCURRENCE		TIME:		A.M. P.M.																										
2. SUBJECT OF REPORT																																			
3. EXACT LOCATION OF OCCURRENCE																																			
4. DESCRIBE WHAT HAPPENED. ESTIMATE PROPERTY DAMAGE, IF ANY																																			
5.									ESTIMATE OF DAMAGES																										
6. LIST STOLEN ITEMS, IF ANY. (EXCEPT CASH)																																			
<table border="1" style="width:100%; border-collapse: collapse;"> <thead> <tr> <th style="width:10%;">QUANTITY</th> <th style="width:45%;">TYPE OF ITEM OR EQUIPMENT, DESCRIBE</th> <th style="width:10%;">DEPT. NO.</th> <th style="width:10%;">SERIAL NO.</th> <th style="width:15%;">APPROX. VALUE</th> </tr> </thead> <tbody> <tr><td> </td><td> </td><td> </td><td> </td><td> </td></tr> <tr><td> </td><td> </td><td> </td><td> </td><td> </td></tr> <tr><td> </td><td> </td><td> </td><td> </td><td> </td></tr> <tr><td> </td><td> </td><td> </td><td> </td><td> </td></tr> </tbody> </table>											QUANTITY	TYPE OF ITEM OR EQUIPMENT, DESCRIBE	DEPT. NO.	SERIAL NO.	APPROX. VALUE																				
QUANTITY	TYPE OF ITEM OR EQUIPMENT, DESCRIBE	DEPT. NO.	SERIAL NO.	APPROX. VALUE																															
7.									TOTAL																										
8. IF MONEY WAS TAKEN, INDICATE AMOUNT AND WHERE KEPT AT TIME OF THEFT. CALL CHIEF ACCOUNTANT AT 213 473-6981									AMOUNT																										
LOCATION																																			
9 TOTAL LOSSES (TOTAL OF LINES 5, 7 AND 8)									TOTAL																										
10. WHO DISCOVERED LOSS?				TITLE		DATE		TIME:		A.M. P.M.																									
NAME																																			
11. HOW WAS ENTRANCE GAINED?																																			
12. WHO SECURED BLDG. PRIOR TO OCCURRENCE?				TITLE		DATE		TIME:		A.M. P.M.																									
NAME																																			
13. WAS POLICE REPORT MADE?			YES <input type="checkbox"/>	NO <input type="checkbox"/>	D.R. NUMBER																														
14. HAS A WORK ORDER BEEN INITIATED FOR REPAIRS?						YES <input type="checkbox"/>		NO <input type="checkbox"/>		WORK ORDER NO.																									
15. PERSONS INVOLVED:																																			
WITNESS <input type="checkbox"/>			VICTIM <input type="checkbox"/>			SUSPECT <input type="checkbox"/>																													
NAME		ADDRESS				AGE	SEX	PHONE NUMBER		INDICATE																									
										W V S																									
										W V S																									
										W V S																									
										W V S																									
16. IF VEHICLE INVOLVED:			LICENSE NO.		OWNERS NAME, ADDRESS AND INSURANCE CO.																														
YEAR		MAKE																																	
17. WHAT CORRECTIVE ACTIONS DO YOU RECOMMEND BE TAKEN TO AVOID FURTHER OCCURRENCES?																																			
18. REPORT SUBMITTED BY:					NAME			TITLE		DATE																									

(IF MORE SPACE IS NEEDED, USE PAGE 2)

INSTRUCTIONS: This report must be made out in reporting any damage to, theft or loss of, private or public property or any other reportable incident occurring at any department facility and report to any member of the staff. This report to be filled out and distributed within 24 hours of incident. This form is NOT to be used for injury, accident or illness to City Employees or Non-City employees. Use general forms numbers 166 or 87 for these purposes.

FILL OUT FORM AS COMPLETE AS POSSIBLE USING THE

1. Name of recreation center, park etc. date and time (if known) incident occurred.
2. Subject of report may be vandalism, theft, fire, defacing public property, indecent exposure, etc.
3. Exact location of incident at facility i.e. gym, boys restroom, merry-go-round, ball diamond, etc.
4. Describe incident, give details. Use other side of form if necessary.
5. Estimate property damage, if any, incurred as a result of the described incident.
6. List stolen or lost items. Give identifying numbers and approximate replacement cost.
7. Total cost of stolen or lost items.
8. If cash taken, state amount and location. i.e. \$10.00 from coke machine, \$50.00 from safe, etc.
9. Total losses. Add up the amounts from 5,7, and 8
10. Name and title of person discovering the loss. Give date and time discovered.
11. Describe how bldg. was entered, i.e. unauthorized key, kitchen window, forced open office door, etc.
12. Name and title of person locking up premises before incident occurred. Give date and time secured.
13. When reporting incident to police, request that reporting officer call his station and obtain a D.R. number. Enter this number on line no. 13
14. If repairs are needed, initiate job order through channels and record Work Order number on line no. 14.
15. Obtain requested information on any persons involved. Be as complete as possible.
16. Give requested information on any city or non-city-owned vehicle involved in the purpose of this report.
17. Give any recommendations for corrective actions that should be taken to avoid further incidents.
18. Name and title of person making this report. Date report made out.

STANDARD PROVISIONS FOR CITY CONTRACTS

TABLE OF CONTENTS

PSC-1	<u>CONSTRUCTION OF PROVISIONS AND TITLES HEREIN</u>	1
PSC-2	<u>NUMBER OF ORIGINALS</u>	1
PSC-3	<u>APPLICABLE LAW, INTERPRETATION AND ENFORCEMENT</u>	1
PSC-4	<u>TIME OF EFFECTIVENESS</u>	2
PSC-5	<u>INTEGRATED CONTRACT</u>	2
PSC-6	<u>AMENDMENT</u>	2
PSC-7	<u>EXCUSABLE DELAYS</u>	2
PSC-8	<u>BREACH</u>	2
PSC-9	<u>WAIVER</u>	3
PSC-10	<u>TERMINATION</u>	3
PSC-11	<u>INDEPENDENT CONTRACTOR</u>	4
PSC-12	<u>CONTRACTOR'S PERSONNEL</u>	4
PSC-13	<u>PROHIBITION AGAINST ASSIGNMENT OR DELEGATION</u>	5
PSC-14	<u>PERMITS</u>	5
PSC-15	<u>CLAIMS FOR LABOR AND MATERIALS</u>	5
PSC-16	<u>CURRENT LOS ANGELES CITY BUSINESS TAX REGISTRATION CERTIFICATE REQUIRED</u>	5
PSC-17	<u>RETENTION OF RECORDS, AUDIT AND REPORTS</u>	5
PSC-18	<u>FALSE CLAIMS ACT</u>	6
PSC-19	<u>BONDS</u>	6
PSC-20	<u>INDEMNIFICATION</u>	6
PSC-21	<u>INTELLECTUAL PROPERTY INDEMNIFICATION</u>	6

TABLE OF CONTENTS (Continued)

PSC-22	<u>INTELLECTUAL PROPERTY WARRANTY</u>	7
PSC-23	<u>OWNERSHIP AND LICENSE</u>	7
PSC-24	<u>INSURANCE</u>	8
PSC-25	<u>DISCOUNT TERMS</u>	8
PSC-26	<u>WARRANTY AND RESPONSIBILITY OF CONTRACTOR</u>	8
PSC-27	<u>NON-DISCRIMINATION</u>	8
PSC-28	<u>EQUAL EMPLOYMENT PRACTICES</u>	9
PSC-29	<u>AFFIRMATIVE ACTION PROGRAM</u>	11
PSC-30	<u>CHILD SUPPORT ASSIGNMENT ORDERS</u>	15
PSC-31	<u>LIVING WAGE ORDINANCE AND SERVICE CONTRACTOR WORKER RETENTION ORDINANCE</u>	16
PSC-32	<u>AMERICANS WITH DISABILITIES ACT</u>	17
PSC-33	<u>CONTRACTOR RESPONSIBILITY ORDINANCE</u>	18
PSC-34	<u>MINORITY, WOMEN, AND OTHER BUSINESS ENTERPRISE OUTREACH PROGRAM</u>	18
PSC-35	<u>EQUAL BENEFITS ORDINANCE</u>	18
PSC-36	<u>SLAVERY DISCLOSURE ORDINANCE</u>	19
EXHIBIT 1	- INSURANCE CONTRACTUAL REQUIREMENTS	20

STANDARD PROVISIONS FOR CITY CONTRACTS

PSC-1. CONSTRUCTION OF PROVISIONS AND TITLES HEREIN

All titles, subtitles, or headings in this Contract have been inserted for convenience, and shall not be deemed to affect the meaning or construction of any of the terms or provisions hereof. The language of this Contract shall be construed according to its fair meaning and not strictly for or against the **CITY** or **CONTRACTOR**. The word "**CONTRACTOR**" herein in this Contract includes the party or parties identified in the Contract. The singular shall include the plural; if there is more than one **CONTRACTOR** herein, unless expressly stated otherwise, their obligations and liabilities hereunder shall be joint and several. Use of the feminine, masculine, or neuter genders shall be deemed to include the genders not used.

PSC-2. NUMBER OF ORIGINALS

The number of original texts of this Contract shall be equal to the number of the parties hereto, one text being retained by each party. At the **CITY'S** option, one or more additional original texts of this Contract may also be retained by the City.

PSC-3. APPLICABLE LAW, INTERPRETATION AND ENFORCEMENT

Each party's performance hereunder shall comply with all applicable laws of the United States of America, the State of California, and the **CITY**, including but not limited to, laws regarding health and safety, labor and employment, wage and hours and licensing laws which affect employees. This Contract shall be enforced and interpreted under the laws of the State of California without regard to conflict of law principles. **CONTRACTOR** shall comply with new, amended, or revised laws, regulations, and/or procedures that apply to the performance of this Contract.

In any action arising out of this Contract, **CONTRACTOR** consents to personal jurisdiction, and agrees to bring all such actions, exclusively in state or federal courts located in Los Angeles County, California.

If any part, term or provision of this Contract is held void, illegal, unenforceable, or in conflict with any law of a federal, state or local government having jurisdiction over this Contract, the validity of the remaining parts, terms or provisions of the Contract shall not be affected thereby.

PSC-4. TIME OF EFFECTIVENESS

Unless otherwise provided, this Contract shall take effect when all of the following events have occurred:

- A. This Contract has been signed on behalf of **CONTRACTOR** by the person or persons authorized to bind **CONTRACTOR** hereto;
- B. This Contract has been approved by the City Council or by the board, officer or employee authorized to give such approval;
- C. The Office of the City Attorney has indicated in writing its approval of this Contract as to form; and
- D. This Contract has been signed on behalf of the **CITY** by the person designated by the City Council, or by the board, officer or employee authorized to enter into this Contract.

PSC-5. INTEGRATED CONTRACT

This Contract sets forth all of the rights and duties of the parties with respect to the subject matter hereof, and replaces any and all previous Contracts or understandings, whether written or oral, relating thereto. This Contract may be amended only as provided for in paragraph PSC-6 hereof.

PSC-6. AMENDMENT

All amendments to this Contract shall be in writing and signed and approved pursuant to the provisions of PSC-4.

PSC-7. EXCUSABLE DELAYS

In the event that performance on the part of any party hereto is delayed or suspended as a result of circumstances beyond the reasonable control and without the fault and negligence of said party, none of the parties shall incur any liability to the other parties as a result of such delay or suspension. Circumstances deemed to be beyond the control of the parties hereunder include, but are not limited to, acts of God or of the public enemy; insurrection; acts of the Federal Government or any unit of State or Local Government in either sovereign or contractual capacity; fires; floods; earthquakes; epidemics; quarantine restrictions; strikes; freight embargoes or delays in transportation, to the extent that they are not caused by the party's willful or negligent acts or omissions, and to the extent that they are beyond the party's reasonable control.

PSC-8. BREACH

Except for excusable delays as described in PSC-7, if any party fails to perform, in whole or in part, any promise, covenant, or agreement set forth herein, or should any representation made by it be untrue, any aggrieved party may avail itself of all rights

and remedies, at law or equity, in the courts of law. Said rights and remedies are cumulative of those provided for herein except that in no event shall any party recover more than once, suffer a penalty or forfeiture, or be unjustly compensated.

PSC-9. WAIVER

A waiver of a default of any part, term or provision of this Contract shall not be construed as a waiver of any succeeding default or as a waiver of the part, term or provision itself. A party's performance after the other party's default shall not be construed as a waiver of that default.

PSC-10. TERMINATION

A. TERMINATION FOR CONVENIENCE

The **CITY** may terminate this Contract for the **CITY'S** convenience at any time by giving **CONTRACTOR** thirty days written notice thereof. Upon receipt of said notice, **CONTRACTOR** shall immediately take action not to incur any additional obligations, cost or expenses, except as may be reasonably necessary to terminate its activities. The **CITY** shall pay **CONTRACTOR** its reasonable and allowable costs through the effective date of termination and those reasonable and necessary costs incurred by **CONTRACTOR** to affect such termination. Thereafter, **CONTRACTOR** shall have no further claims against the **CITY** under this Contract. All finished and unfinished documents and materials procured for or produced under this Contract, including all intellectual property rights thereto, shall become **CITY** property upon the date of such termination. **CONTRACTOR** agrees to execute any documents necessary for the **CITY** to perfect, memorialize, or record the **CITY'S** ownership of rights provided herein.

B. TERMINATION FOR BREACH OF CONTRACT

1. Except for excusable delays as provided in PSC-7, if **CONTRACTOR** fails to perform any of the provisions of this Contract or so fails to make progress as to endanger timely performance of this Contract, the **CITY** may give **CONTRACTOR** written notice of such default. If **CONTRACTOR** does not cure such default or provide a plan to cure such default which is acceptable to the **CITY** within the time permitted by the **CITY**, then the **CITY** may terminate this Contract due to **CONTRACTOR'S** breach of this Contract.
2. If a federal or state proceeding for relief of debtors is undertaken by or against **CONTRACTOR**, or if **CONTRACTOR** makes an assignment for the benefit of creditors, then the **CITY** may immediately terminate this Contract.
3. If **CONTRACTOR** engages in any dishonest conduct related to the performance or administration of this Contract or violates the

CITY'S lobbying policies, then the **CITY** may immediately terminate this Contract.

4. In the event the **CITY** terminates this Contract as provided in this section, the **CITY** may procure, upon such terms and in such manner as the **CITY** may deem appropriate, services similar in scope and level of effort to those so terminated, and **CONTRACTOR** shall be liable to the **CITY** for all of its costs and damages, including, but not limited, any excess costs for such services.
5. All finished or unfinished documents and materials produced or procured under this Contract, including all intellectual property rights thereto, shall become **CITY** property upon date of such termination. **CONTRACTOR** agrees to execute any documents necessary for the **CITY** to perfect, memorialize, or record the **CITY'S** ownership of rights provided herein.
6. If, after notice of termination of this Contract under the provisions of this section, it is determined for any reason that **CONTRACTOR** was not in default under the provisions of this section, or that the default was excusable under the terms of this Contract, the rights and obligations of the parties shall be the same as if the notice of termination had been issued pursuant to PSC-10(A) Termination for Convenience.
7. The rights and remedies of the **CITY** provided in this section shall not be exclusive and are in addition to any other rights and remedies provided by law or under this Contract.

PSC-11. INDEPENDENT CONTRACTOR

CONTRACTOR is acting hereunder as an independent contractor and not as an agent or employee of the **CITY**. **CONTRACTOR** shall not represent or otherwise hold out itself or any of its directors, officers, partners, employees, or agents to be an agent or employee of the **CITY**.

PSC-12. CONTRACTOR'S PERSONNEL

Unless otherwise provided or approved by the **CITY**, **CONTRACTOR** shall use its own employees to perform the services described in this Contract. The **CITY** shall have the right to review and approve any personnel who are assigned to work under this Contract. **CONTRACTOR** agrees to remove personnel from performing work under this Contract if requested to do so by the **CITY**.

CONTRACTOR shall not use subcontractors to assist in performance of this Contract without the prior written approval of the **CITY**. If the **CITY** permits the use of subcontractors, **CONTRACTOR** shall remain responsible for performing all aspects of

this Contract. The **CITY** has the right to approve **CONTRACTOR'S** subcontractors, and the **CITY** reserves the right to request replacement of subcontractors. The **CITY** does not have any obligation to pay **CONTRACTOR'S** subcontractors, and nothing herein creates any privity between the **CITY** and the subcontractors.

PSC-13. PROHIBITION AGAINST ASSIGNMENT OR DELEGATION

CONTRACTOR may not, unless it has first obtained the written permission of the **CITY**:

- A. Assign or otherwise alienate any of its rights under this Contract, including the right to payment; or
- B. Delegate, subcontract, or otherwise transfer any of its duties under this Contract.

PSC-14. PERMITS

CONTRACTOR and its directors, officers, partners, agents, employees, and subcontractors, to the extent allowed hereunder, shall obtain and maintain all licenses, permits, certifications and other documents necessary for **CONTRACTOR'S** performance hereunder and shall pay any fees required therefor. **CONTRACTOR** certifies to immediately notify the **CITY** of any suspension, termination, lapses, non-renewals, or restrictions of licenses, permits, certificates, or other documents.

PSC-15. CLAIMS FOR LABOR AND MATERIALS

CONTRACTOR shall promptly pay when due all amounts payable for labor and materials furnished in the performance of this Contract so as to prevent any lien or other claim under any provision of law from arising against any **CITY** property (including reports, documents, and other tangible or intangible matter produced by **CONTRACTOR** hereunder), against **CONTRACTOR'S** rights to payments hereunder, or against the **CITY**, and shall pay all amounts due under the Unemployment Insurance Act with respect to such labor.

PSC-16. CURRENT LOS ANGELES CITY BUSINESS TAX REGISTRATION CERTIFICATE REQUIRED

If applicable, **CONTRACTOR** represents that it has obtained and presently holds the Business Tax Registration Certificate(s) required by the **CITY'S** Business Tax Ordinance, Section 21.00 *et seq.* of the Los Angeles Municipal Code. For the term covered by this Contract, **CONTRACTOR** shall maintain, or obtain as necessary, all such Certificates required of it under the Business Tax Ordinance, and shall not allow any such Certificate to be revoked or suspended.

PSC-17. RETENTION OF RECORDS, AUDIT AND REPORTS

CONTRACTOR shall maintain all records, including records of financial transactions, pertaining to the performance of this Contract, in their original form, in accordance with

requirements prescribed by the **CITY**. These records shall be retained for a period of no less than three years following final payment made by the **CITY** hereunder or the expiration date of this Contract, whichever occurs last. Said records shall be subject to examination and audit by authorized **CITY** personnel or by the **CITY'S** representative at any time during the term of this Contract or within the three years following final payment made by the **CITY** hereunder or the expiration date of this Contract, whichever occurs last. **CONTRACTOR** shall provide any reports requested by the **CITY** regarding performance of this Contract. Any subcontract entered into by **CONTRACTOR**, to the extent allowed hereunder, shall include a like provision for work to be performed under this Contract.

PSC-18. FALSE CLAIMS ACT

CONTRACTOR acknowledges that it is aware of liabilities resulting from submitting a false claim for payment by the **CITY** under the False Claims Act (Cal. Gov. Code §§ 12650 *et seq.*), including treble damages, costs of legal actions to recover payments, and civil penalties of up to \$10,000 per false claim.

PSC-19. BONDS

All bonds which may be required hereunder shall conform to **CITY** requirements established by Charter, ordinance or policy, and shall be filed with the Office of the City Administrative Officer, Risk Management for its review and acceptance in accordance with Sections 11.47 through 11.56 of the Los Angeles Administrative Code.

PSC-20. INDEMNIFICATION

Except for the active negligence or willful misconduct of the **CITY**, or any of its Boards, Officers, Agents, Employees, Assigns and Successors in Interest, **CONTRACTOR** undertakes and agrees to defend, indemnify and hold harmless the **CITY** and any of its Boards, Officers, Agents, Employees, Assigns, and Successors in Interest from and against all suits and causes of action, claims, losses, demands and expenses, including, but not limited to, attorney's fees (both in house and outside counsel) and cost of litigation (including all actual litigation costs incurred by the **CITY**, including but not limited to, costs of experts and consultants), damages or liability of any nature whatsoever, for death or injury to any person, including **CONTRACTOR'S** employees and agents, or damage or destruction of any property of either party hereto or of third parties, arising in any manner by reason of the negligent acts, errors, omissions or willful misconduct incident to the performance of this Contract by **CONTRACTOR** or its subcontractors of any tier. Rights and remedies available to the **CITY** under this provision are cumulative of those provided for elsewhere in this Contract and those allowed under the laws of the United States, the State of California, and the **CITY**. The provisions of PSC-20 shall survive expiration or termination of this Contract.

PSC-21. INTELLECTUAL PROPERTY INDEMNIFICATION

CONTRACTOR, at its own expense, undertakes and agrees to defend, indemnify, and hold harmless the **CITY**, and any of its Boards, Officers, Agents, Employees, Assigns,

and Successors in Interest from and against all suits and causes of action, claims, losses, demands and expenses, including, but not limited to, attorney's fees (both in house and outside counsel) and cost of litigation (including all actual litigation costs incurred by the **CITY**, including but not limited to, costs of experts and consultants), damages or liability of any nature whatsoever arising out of the infringement, actual or alleged, direct or contributory, of any intellectual property rights, including, without limitation, patent, copyright, trademark, trade secret, right of publicity and proprietary information right (1) on or in any design, medium, matter, article, process, method, application, equipment, device, instrumentation, software, hardware, or firmware used by **CONTRACTOR**, or its subcontractors of any tier, in performing the work under this Contract; or (2) as a result of the **CITY'S** actual or intended use of any Work Product furnished by **CONTRACTOR**, or its subcontractors of any tier, under the Agreement. Rights and remedies available to the **CITY** under this provision are cumulative of those provided for elsewhere in this Contract and those allowed under the laws of the United States, the State of California, and the **CITY**. The provisions of PSC-21 shall survive expiration or termination of this Contract.

PSC-22. INTELLECTUAL PROPERTY WARRANTY

CONTRACTOR represents and warrants that its performance of all obligations under this Contract does not infringe in any way, directly or contributorily, upon any third party's intellectual property rights, including, without limitation, patents, copyrights, trademarks, trade secrets, rights of publicity and proprietary information.

PSC-23. OWNERSHIP AND LICENSE

Unless otherwise provided for herein, all Work Products originated and prepared by **CONTRACTOR** or its subcontractors of any tier under this Contract shall be and remain the exclusive property of the **CITY** for its use in any manner it deems appropriate. Work Products are all works, tangible or not, created under this Contract including, without limitation, documents, material, data, reports, manuals, specifications, artwork, drawings, sketches, computer programs and databases, schematics, photographs, video and audiovisual recordings, sound recordings, marks, logos, graphic designs, notes, websites, domain names, inventions, processes, formulas matters and combinations thereof, and all forms of intellectual property. **CONTRACTOR** hereby assigns, and agrees to assign, all goodwill, copyright, trademark, patent, trade secret and all other intellectual property rights worldwide in any Work Products originated and prepared by **CONTRACTOR** under this Contract. **CONTRACTOR** further agrees to execute any documents necessary for the **CITY** to perfect, memorialize, or record the **CITY'S** ownership of rights provided herein.

For all Work Products delivered to the **CITY** that are not originated or prepared by **CONTRACTOR** or its subcontractors of any tier under this Contract, **CONTRACTOR** hereby grants a non-exclusive perpetual license to use such Work Products for any **CITY** purposes.

CONTRACTOR shall not provide or disclose any Work Product to any third party without prior written consent of the **CITY**.

Any subcontract entered into by **CONTRACTOR** relating to this Contract, to the extent allowed hereunder, shall include a like provision for work to be performed under this Contract to contractually bind or otherwise oblige its subcontractors performing work under this Contract such that the **CITY'S** ownership and license rights of all Work Products are preserved and protected as intended herein. Failure of **CONTRACTOR** to comply with this requirement or to obtain the compliance of its subcontractors with such obligations shall subject **CONTRACTOR** to the imposition of any and all sanctions allowed by law, including but not limited to termination of **CONTRACTOR'S** contract with the **CITY**.

PSC-24. INSURANCE

During the term of this Contract and without limiting **CONTRACTOR'S** indemnification of the **CITY**, **CONTRACTOR** shall provide and maintain at its own expense a program of insurance having the coverages and limits customarily carried and actually arranged by **CONTRACTOR**, but not less than the amounts and types listed on the Required Insurance and Minimum Limits sheet (Form General 146 in Exhibit 1 hereto), covering its operations hereunder. Such insurance shall conform to **CITY** requirements established by Charter, ordinance or policy, shall comply with the Insurance Contractual Requirements (Form General 133 in Exhibit 1 hereto) and shall otherwise be in a form acceptable to the Office of the City Administrative Officer, Risk Management. **CONTRACTOR** shall comply with all Insurance Contractual Requirements shown on Exhibit 1 hereto. Exhibit 1 is hereby incorporated by reference and made a part of this Contract.

PSC-25. DISCOUNT TERMS

CONTRACTOR agrees to offer the **CITY** any discount terms that are offered to its best customers for the goods and services to be provided hereunder and apply such discount to payments made under this Contract which meet the discount terms.

PSC-26. WARRANTY AND RESPONSIBILITY OF CONTRACTOR

CONTRACTOR warrants that the work performed hereunder shall be completed in a manner consistent with professional standards practiced among those firms within **CONTRACTOR'S** profession, doing the same or similar work under the same or similar circumstances.

PSC-27. NON-DISCRIMINATION

Unless otherwise exempt, this Contract is subject to the non-discrimination provisions in Sections 10.8 through 10.8.2 of the Los Angeles Administrative Code, as amended from time to time. The **CONTRACTOR** shall comply with the applicable non-discrimination and affirmative action provisions of the laws of the United States of America, the State of California, and the **CITY**. In performing this Contract, **CONTRACTOR** shall not

discriminate in its employment practices against any employee or applicant for employment because of such person's race, religion, national origin, ancestry, sex, sexual orientation, age, disability, domestic partner status, marital status or medical condition. Any subcontract entered into by **CONTRACTOR**, to the extent allowed hereunder, shall include a like provision for work to be performed under this Contract.

Failure of **CONTRACTOR** to comply with this requirement or to obtain the compliance of its subcontractors with such obligations shall subject **CONTRACTOR** to the imposition of any and all sanctions allowed by law, including but not limited to termination of **CONTRACTOR'S** contract with the **CITY**.

PSC-28. EQUAL EMPLOYMENT PRACTICES

Unless otherwise exempt, this Contract is subject to the equal employment practices provisions in Section 10.8.3 of the Los Angeles Administrative Code, as amended from time to time.

- A. During the performance of this Contract, **CONTRACTOR** agrees and represents that it will provide equal employment practices and **CONTRACTOR** and each subcontractor hereunder will ensure that in his or her employment practices persons are employed and employees are treated equally and without regard to or because of race, religion, ancestry, national origin, sex, sexual orientation, age, disability, marital status or medical condition.
 - 1. This provision applies to work or service performed or materials manufactured or assembled in the United States.
 - 2. Nothing in this section shall require or prohibit the establishment of new classifications of employees in any given craft, work or service category.
 - 3. **CONTRACTOR** agrees to post a copy of Paragraph A hereof in conspicuous places at its place of business available to employees and applicants for employment.
- B. **CONTRACTOR** will, in all solicitations or advertisements for employees placed by or on behalf of **CONTRACTOR**, state that all qualified applicants will receive consideration for employment without regard to their race, religion, ancestry, national origin, sex, sexual orientation, age, disability, marital status or medical condition.
- C. As part of the **CITY'S** supplier registration process, and/or at the request of the awarding authority, or the Board of Public Works, Office of Contract Compliance, **CONTRACTOR** shall certify in the specified format that he or she has not discriminated in the performance of **CITY** contracts against any employee or applicant for employment on the basis or because of

race, religion, national origin, ancestry, sex, sexual orientation, age, disability, marital status or medical condition.

- D. **CONTRACTOR** shall permit access to and may be required to provide certified copies of all of his or her records pertaining to employment and to employment practices by the awarding authority or the Office of Contract Compliance for the purpose of investigation to ascertain compliance with the Equal Employment Practices provisions of **CITY** contracts. On their or either of their request **CONTRACTOR** shall provide evidence that he or she has or will comply therewith.
- E. The failure of any **CONTRACTOR** to comply with the Equal Employment Practices provisions of this Contract may be deemed to be a material breach of **CITY** contracts. Such failure shall only be established upon a finding to that effect by the awarding authority, on the basis of its own investigation or that of the Board of Public Works, Office of Contract Compliance. No such finding shall be made or penalties assessed except upon a full and fair hearing after notice and an opportunity to be heard has been given to **CONTRACTOR**.
- F. Upon a finding duly made that **CONTRACTOR** has failed to comply with the Equal Employment Practices provisions of a **CITY** contract, the contract may be forthwith canceled, terminated or suspended, in whole or in part, by the awarding authority, and all monies due or to become due hereunder may be forwarded to and retained by the **CITY**. In addition thereto, such failure to comply may be the basis for a determination by the awarding authority or the Board of Public Works that the **CONTRACTOR** is an irresponsible bidder or proposer pursuant to the provisions of Section 371 of the Charter of the City of Los Angeles. In the event of such a determination, **CONTRACTOR** shall be disqualified from being awarded a contract with the **CITY** for a period of two years, or until **CONTRACTOR** shall establish and carry out a program in conformance with the provisions hereof.
- G. Notwithstanding any other provision of this Contract, the **CITY** shall have any and all other remedies at law or in equity for any breach hereof.
- H. Intentionally blank.
- I. Nothing contained in this Contract shall be construed in any manner so as to require or permit any act which is prohibited by law.
- J. At the time a supplier registers to do business with the **CITY**, or when an individual bid or proposal is submitted, **CONTRACTOR** shall agree to adhere to the Equal Employment Practices specified herein during the performance or conduct of **CITY** Contracts.

- K. Equal Employment Practices shall, without limitation as to the subject or nature of employment activity, be concerned with such employment practices as:
 - 1. Hiring practices;
 - 2. Apprenticeships where such approved programs are functioning, and other on-the-job training for non-apprenticeable occupations;
 - 3. Training and promotional opportunities; and
 - 4. Reasonable accommodations for persons with disabilities.
- L. Any subcontract entered into by **CONTRACTOR**, to the extent allowed hereunder, shall include a like provision for work to be performed under this Contract. Failure of **CONTRACTOR** to comply with this requirement or to obtain the compliance of its subcontractors with all such obligations shall subject **CONTRACTOR** to the imposition of any and all sanctions allowed by law, including but not limited to termination of the **CONTRACTOR'S** Contract with the **CITY**.

PSC-29. AFFIRMATIVE ACTION PROGRAM

Unless otherwise exempt, this Contract is subject to the affirmative action program provisions in Section 10.8.4 of the Los Angeles Administrative Code, as amended from time to time.

- A. During the performance of a **CITY** contract, **CONTRACTOR** certifies and represents that **CONTRACTOR** and each subcontractor hereunder will adhere to an affirmative action program to ensure that in its employment practices, persons are employed and employees are treated equally and without regard to or because of race, religion, ancestry, national origin, sex, sexual orientation, age, disability, marital status or medical condition.
 - 1. This provision applies to work or services performed or materials manufactured or assembled in the United States.
 - 2. Nothing in this section shall require or prohibit the establishment of new classifications of employees in any given craft, work or service category.
 - 3. **CONTRACTOR** shall post a copy of Paragraph A hereof in conspicuous places at its place of business available to employees and applicants for employment.
- B. **CONTRACTOR** will, in all solicitations or advertisements for employees placed by or on behalf of **CONTRACTOR**, state that all qualified applicants will receive consideration for employment without regard to

their race, religion, ancestry, national origin, sex, sexual orientation, age, disability, marital status or medical condition.

- C. As part of the **CITY'S** supplier registration process, and/or at the request of the awarding authority or the Office of Contract Compliance, **CONTRACTOR** shall certify on an electronic or hard copy form to be supplied, that **CONTRACTOR** has not discriminated in the performance of **CITY** contracts against any employee or applicant for employment on the basis or because of race, religion, ancestry, national origin, sex, sexual orientation, age, disability, marital status or medical condition.
- D. **CONTRACTOR** shall permit access to and may be required to provide certified copies of all of its records pertaining to employment and to its employment practices by the awarding authority or the Office of Contract Compliance, for the purpose of investigation to ascertain compliance with the Affirmative Action Program provisions of **CITY** contracts, and on their or either of their request to provide evidence that it has or will comply therewith.
- E. The failure of any **CONTRACTOR** to comply with the Affirmative Action Program provisions of **CITY** contracts may be deemed to be a material breach of contract. Such failure shall only be established upon a finding to that effect by the awarding authority, on the basis of its own investigation or that of the Board of Public Works, Office of Contract Compliance. No such finding shall be made except upon a full and fair hearing after notice and an opportunity to be heard has been given to **CONTRACTOR**.
- F. Upon a finding duly made that **CONTRACTOR** has breached the Affirmative Action Program provisions of a **CITY** contract, the contract may be forthwith cancelled, terminated or suspended, in whole or in part, by the awarding authority, and all monies due or to become due hereunder may be forwarded to and retained by the **CITY**. In addition thereto, such breach may be the basis for a determination by the awarding authority or the Board of Public Works that the said **CONTRACTOR** is an irresponsible bidder or proposer pursuant to the provisions of Section 371 of the Los Angeles City Charter. In the event of such determination, such **CONTRACTOR** shall be disqualified from being awarded a contract with the **CITY** for a period of two years, or until he or she shall establish and carry out a program in conformance with the provisions hereof.
- G. In the event of a finding by the Fair Employment and Housing Commission of the State of California, or the Board of Public Works of the City of Los Angeles, or any court of competent jurisdiction, that **CONTRACTOR** has been guilty of a willful violation of the California Fair Employment and Housing Act, or the Affirmative Action Program provisions of a **CITY** contract, there may be deducted from the amount payable to **CONTRACTOR** by the **CITY** under the contract, a penalty of ten dollars

(\$10.00) for each person for each calendar day on which such person was discriminated against in violation of the provisions of a **CITY** contract.

- H. Notwithstanding any other provisions of a **CITY** contract, the **CITY** shall have any and all other remedies at law or in equity for any breach hereof.
- I. Intentionally blank.
- J. Nothing contained in **CITY** contracts shall be construed in any manner so as to require or permit any act which is prohibited by law.
- K. **CONTRACTOR** shall submit an Affirmative Action Plan which shall meet the requirements of this chapter at the time it submits its bid or proposal or at the time it registers to do business with the **CITY**. The plan shall be subject to approval by the Office of Contract Compliance prior to award of the contract. The awarding authority may also require contractors and suppliers to take part in a pre-registration, pre-bid, pre-proposal, or pre-award conference in order to develop, improve or implement a qualifying Affirmative Action Plan. Affirmative Action Programs developed pursuant to this section shall be effective for a period of twelve months from the date of approval by the Office of Contract Compliance. In case of prior submission of a plan, **CONTRACTOR** may submit documentation that it has an Affirmative Action Plan approved by the Office of Contract Compliance within the previous twelve months. If the approval is 30 days or less from expiration, **CONTRACTOR** must submit a new Plan to the Office of Contract Compliance and that Plan must be approved before the contract is awarded.
 - 1. Every contract of \$5,000 or more which may provide construction, demolition, renovation, conservation or major maintenance of any kind shall in addition comply with the requirements of Section 10.13 of the Los Angeles Administrative Code.
 - 2. **CONTRACTOR** may establish and adopt as its own Affirmative Action Plan, by affixing his or her signature thereto, an Affirmative Action Plan prepared and furnished by the Office of Contract Compliance, or it may prepare and submit its own Plan for approval.
- L. The Office of Contract Compliance shall annually supply the awarding authorities of the **CITY** with a list of contractors and suppliers who have developed Affirmative Action Programs. For each contractor and supplier the Office of Contract Compliance shall state the date the approval expires. The Office of Contract Compliance shall not withdraw its approval for any Affirmative Action Plan or change the Affirmative Action Plan after the date of contract award for the entire contract term without the mutual agreement of the awarding authority and **CONTRACTOR**.

- M. The Affirmative Action Plan required to be submitted hereunder and the pre-registration, pre-bid, pre-proposal or pre-award conference which may be required by the Board of Public Works, Office of Contract Compliance or the awarding authority shall, without limitation as to the subject or nature of employment activity, be concerned with such employment practices as:
1. Apprenticeship where approved programs are functioning, and other on-the-job training for non-apprenticeable occupations;
 2. Classroom preparation for the job when not apprenticeable;
 3. Pre-apprenticeship education and preparation;
 4. Upgrading training and opportunities;
 5. Encouraging the use of contractors, subcontractors and suppliers of all racial and ethnic groups, provided, however, that any contract subject to this ordinance shall require the contractor, subcontractor or supplier to provide not less than the prevailing wage, working conditions and practices generally observed in private industries in the contractor's, subcontractor's or supplier's geographical area for such work;
 6. The entry of qualified women, minority and all other journeymen into the industry; and
 7. The provision of needed supplies or job conditions to permit persons with disabilities to be employed, and minimize the impact of any disability.
- N. Any adjustments which may be made in the contractor's or supplier's workforce to achieve the requirements of the **CITY'S** Affirmative Action Contract Compliance Program in purchasing and construction shall be accomplished by either an increase in the size of the workforce or replacement of those employees who leave the workforce by reason of resignation, retirement or death and not by termination, layoff, demotion or change in grade.
- O. Affirmative Action Agreements resulting from the proposed Affirmative Action Plan or the pre-registration, pre-bid, pre-proposal or pre-award conferences shall not be confidential and may be publicized by the contractor at his or her discretion. Approved Affirmative Action Agreements become the property of the **CITY** and may be used at the discretion of the **CITY** in its Contract Compliance Affirmative Action Program.
- P. Intentionally blank.

- Q. All contractors subject to the provisions of this section shall include a like provision in all subcontracts awarded for work to be performed under the contract with the **CITY** and shall impose the same obligations, including but not limited to filing and reporting obligations, on the subcontractors as are applicable to the contractor. Failure of the contractor to comply with this requirement or to obtain the compliance of its subcontractors with all such obligations shall subject the contractor to the imposition of any and all sanctions allowed by law, including but not limited to termination of the contractor's contract with the **CITY**.

PSC-30. CHILD SUPPORT ASSIGNMENT ORDERS

This Contract is subject to the Child Support Assignment Orders Ordinance, Section 10.10 of the Los Angeles Administrative Code, as amended from time to time. Pursuant to the Child Support Assignment Orders Ordinance, **CONTRACTOR** will fully comply with all applicable State and Federal employment reporting requirements for **CONTRACTOR'S** employees. **CONTRACTOR** shall also certify (1) that the Principal Owner(s) of **CONTRACTOR** are in compliance with any Wage and Earnings Assignment Orders and Notices of Assignment applicable to them personally; (2) that **CONTRACTOR** will fully comply with all lawfully served Wage and Earnings Assignment Orders and Notices of Assignment in accordance with Section 5230, *et seq.* of the California Family Code; and (3) that **CONTRACTOR** will maintain such compliance throughout the term of this Contract.

Pursuant to Section 10.10(b) of the Los Angeles Administrative Code, the failure of **CONTRACTOR** to comply with all applicable reporting requirements or to implement lawfully served Wage and Earnings Assignment Orders or Notices of Assignment, or the failure of any Principal Owner(s) of **CONTRACTOR** to comply with any Wage and Earnings Assignment Orders or Notices of Assignment applicable to them personally, shall constitute a default by the **CONTRACTOR** under this Contract, subjecting this Contract to termination if such default shall continue for more than ninety (90) days after notice of such default to **CONTRACTOR** by the **CITY**.

Any subcontract entered into by **CONTRACTOR**, to the extent allowed hereunder, shall include a like provision for work to be performed under this Contract. Failure of **CONTRACTOR** to obtain compliance of its subcontractors shall constitute a default by **CONTRACTOR** under this Contract, subjecting this Contract to termination where such default shall continue for more than ninety (90) days after notice of such default to **CONTRACTOR** by the **CITY**.

CONTRACTOR certifies that, to the best of its knowledge, it is fully complying with the Earnings Assignment Orders of all employees, and is providing the names of all new employees to the New Hire Registry maintained by the Employment Development Department as set forth in Section 7110(b) of the California Public Contract Code.

PSC-31. LIVING WAGE ORDINANCE AND SERVICE CONTRACTOR WORKER RETENTION ORDINANCE

- A. Unless otherwise exempt, this Contract is subject to the applicable provisions of the Living Wage Ordinance (LWO), Section 10.37 *et seq.* of the Los Angeles Administrative Code, as amended from time to time, and the Service Contractor Worker Retention Ordinance (SCWRO), Section 10.36 *et seq.*, of the Los Angeles Administrative Code, as amended from time to time. These Ordinances require the following:
1. **CONTRACTOR** assures payment of a minimum initial wage rate to employees as defined in the LWO and as may be adjusted each July 1 and provision of compensated and uncompensated days off and health benefits, as defined in the LWO.
 2. **CONTRACTOR** further pledges that it will comply with federal law proscribing retaliation for union organizing and will not retaliate for activities related to the LWO. **CONTRACTOR** shall require each of its subcontractors within the meaning of the LWO to pledge to comply with the terms of federal law proscribing retaliation for union organizing. **CONTRACTOR** shall deliver the executed pledges from each such subcontractor to the **CITY** within ninety (90) days of the execution of the subcontract. **CONTRACTOR'S** delivery of executed pledges from each such subcontractor shall fully discharge the obligation of **CONTRACTOR** with respect to such pledges and fully discharge the obligation of **CONTRACTOR** to comply with the provision in the LWO contained in Section 10.37.6(c) concerning compliance with such federal law.
 3. **CONTRACTOR**, whether an employer, as defined in the LWO, or any other person employing individuals, shall not discharge, reduce in compensation, or otherwise discriminate against any employee for complaining to the **CITY** with regard to the employer's compliance or anticipated compliance with the LWO, for opposing any practice proscribed by the LWO, for participating in proceedings related to the LWO, for seeking to enforce his or her rights under the LWO by any lawful means, or otherwise asserting rights under the LWO. **CONTRACTOR** shall post the Notice of Prohibition Against Retaliation provided by the **CITY**.
 4. Any subcontract entered into by **CONTRACTOR** relating to this Contract, to the extent allowed hereunder, shall be subject to the provisions of PSC-31 and shall incorporate the provisions of the LWO and the SCWRO.

5. **CONTRACTOR** shall comply with all rules, regulations and policies promulgated by the **CITY'S** Designated Administrative Agency which may be amended from time to time.
- B. Under the provisions of Sections 10.36.3(c) and 10.37.6(c) of the Los Angeles Administrative Code, the **CITY** shall have the authority, under appropriate circumstances, to terminate this Contract and otherwise pursue legal remedies that may be available if the **CITY** determines that the subject **CONTRACTOR** has violated provisions of either the LWO or the SCWRO, or both.
- C. Where under the LWO Section 10.37.6(d), the **CITY'S** Designated Administrative Agency has determined (a) that **CONTRACTOR** is in violation of the LWO in having failed to pay some or all of the living wage, and (b) that such violation has gone uncured, the **CITY** in such circumstances may impound monies otherwise due **CONTRACTOR** in accordance with the following procedures. Impoundment shall mean that from monies due **CONTRACTOR**, **CITY** may deduct the amount determined to be due and owing by **CONTRACTOR** to its employees. Such monies shall be placed in the holding account referred to in LWO Section 10.37.6(d)(3) and disposed of under procedures described therein through final and binding arbitration. Whether **CONTRACTOR** is to continue work following an impoundment shall remain in the sole discretion of the **CITY**. **CONTRACTOR** may not elect to discontinue work either because there has been an impoundment or because of the ultimate disposition of the impoundment by the arbitrator.
- D. **CONTRACTOR** shall inform employees making less than Twelve Dollars (\$12.00) per hour of their possible right to the federal Earned Income Credit (EIC). **CONTRACTOR** shall also make available to employees the forms informing them about the EIC and forms required to secure advance EIC payments from **CONTRACTOR**.

PSC-32. AMERICANS WITH DISABILITIES ACT

CONTRACTOR hereby certifies that it will comply with the Americans with Disabilities Act, 42 U.S.C. §§ 12101 *et seq.*, and its implementing regulations. **CONTRACTOR** will provide reasonable accommodations to allow qualified individuals with disabilities to have access to and to participate in its programs, services and activities in accordance with the provisions of the Americans with Disabilities Act. **CONTRACTOR** will not discriminate against persons with disabilities nor against persons due to their relationship to or association with a person with a disability. Any subcontract entered into by **CONTRACTOR**, relating to this Contract, to the extent allowed hereunder, shall be subject to the provisions of this paragraph.

PSC-33. CONTRACTOR RESPONSIBILITY ORDINANCE

Unless otherwise exempt, this Contract is subject to the provisions of the Contractor Responsibility Ordinance, Section 10.40 *et seq.*, of the Los Angeles Administrative Code, as amended from time to time, which requires **CONTRACTOR** to update its responses to the responsibility questionnaire within thirty calendar days after any change to the responses previously provided if such change would affect **CONTRACTOR'S** fitness and ability to continue performing this Contract.

In accordance with the provisions of the Contractor Responsibility Ordinance, by signing this Contract, **CONTRACTOR** pledges, under penalty of perjury, to comply with all applicable federal, state and local laws in the performance of this Contract, including but not limited to, laws regarding health and safety, labor and employment, wages and hours, and licensing laws which affect employees. **CONTRACTOR** further agrees to: (1) notify the **CITY** within thirty calendar days after receiving notification that any government agency has initiated an investigation which may result in a finding that **CONTRACTOR** is not in compliance with all applicable federal, state and local laws in performance of this Contract; (2) notify the **CITY** within thirty calendar days of all findings by a government agency or court of competent jurisdiction that **CONTRACTOR** has violated the provisions of Section 10.40.3(a) of the Contractor Responsibility Ordinance; (3) unless exempt, ensure that its subcontractor(s), as defined in the Contractor Responsibility Ordinance, submit a Pledge of Compliance to the **CITY**; and (4) unless exempt, ensure that its subcontractor(s), as defined in the Contractor Responsibility Ordinance, comply with the requirements of the Pledge of Compliance and the requirement to notify the **CITY** within thirty calendar days after any government agency or court of competent jurisdiction has initiated an investigation or has found that the subcontractor has violated Section 10.40.3(a) of the Contractor Responsibility Ordinance in performance of the subcontract.

PSC-34. MINORITY, WOMEN, AND OTHER BUSINESS ENTERPRISE OUTREACH PROGRAM

CONTRACTOR agrees and obligates itself to utilize the services of Minority, Women and Other Business Enterprise firms on a level so designated in its proposal, if any. **CONTRACTOR** certifies that it has complied with Mayoral Directive 2001-26 regarding the Outreach Program for Personal Services Contracts Greater than \$100,000, if applicable. **CONTRACTOR** shall not change any of these designated subcontractors, nor shall **CONTRACTOR** reduce their level of effort, without prior written approval of the **CITY**, provided that such approval shall not be unreasonably withheld.

PSC-35. EQUAL BENEFITS ORDINANCE

Unless otherwise exempt, this Contract is subject to the provisions of the Equal Benefits Ordinance (EBO), Section 10.8.2.1 of the Los Angeles Administrative Code, as amended from time to time.

- A. During the performance of the Contract, **CONTRACTOR** certifies and represents that **CONTRACTOR** will comply with the EBO.
- B. The failure of **CONTRACTOR** to comply with the EBO will be deemed to be a material breach of this Contract by the **CITY**.
- C. If **CONTRACTOR** fails to comply with the EBO the **CITY** may cancel, terminate or suspend this Contract, in whole or in part, and all monies due or to become due under this Contract may be retained by the **CITY**. The **CITY** may also pursue any and all other remedies at law or in equity for any breach.
- D. Failure to comply with the EBO may be used as evidence against **CONTRACTOR** in actions taken pursuant to the provisions of Los Angeles Administrative Code Section 10.40 *et seq.*, Contractor Responsibility Ordinance.
- E. If the **CITY'S** Designated Administrative Agency determines that a **CONTRACTOR** has set up or used its contracting entity for the purpose of evading the intent of the EBO, the **CITY** may terminate the Contract. Violation of this provision may be used as evidence against **CONTRACTOR** in actions taken pursuant to the provisions of Los Angeles Administrative Code Section 10.40 *et seq.*, Contractor Responsibility Ordinance.

CONTRACTOR shall post the following statement in conspicuous places at its place of business available to employees and applicants for employment:

“During the performance of a Contract with the City of Los Angeles, the Contractor will provide equal benefits to its employees with spouses and its employees with domestic partners. Additional information about the City of Los Angeles’ Equal Benefits Ordinance may be obtained from the Department of Public Works, Office of Contract Compliance at (213) 847-1922.”

PSC-36. SLAVERY DISCLOSURE ORDINANCE

Unless otherwise exempt, this Contract is subject to the Slavery Disclosure Ordinance, Section 10.41 of the Los Angeles Administrative Code, as amended from time to time. **CONTRACTOR** certifies that it has complied with the applicable provisions of the Slavery Disclosure Ordinance. Failure to fully and accurately complete the affidavit may result in termination of this Contract.

EXHIBIT 1

INSURANCE CONTRACTUAL REQUIREMENTS

CONTACT For additional information about compliance with City Insurance and Bond requirements, contact the Office of the City Administrative Officer, Risk Management at (213) 978-RISK (7475) or go online at www.lacity.org/cao/risk. The City approved Bond Assistance Program is available for those contractors who are unable to obtain the City-required performance bonds. A City approved insurance program may be available as a low cost alternative for contractors who are unable to obtain City-required insurance.

CONTRACTUAL REQUIREMENTS

CONTRACTOR AGREES THAT:

1. Additional Insured/Loss Payee. The CITY must be included as an Additional Insured in applicable liability policies to cover the CITY'S liability arising out of the acts or omissions of the named insured. The CITY is to be named as an Additional Named Insured and a Loss Payee As Its Interests May Appear in property insurance in which the CITY has an interest, e.g., as a lien holder.

2. Notice of Cancellation. All required insurance will be maintained in full force for the duration of its business with the CITY. By ordinance, all required insurance must provide at least thirty (30) days' prior written notice (ten (10) days for non-payment of premium) directly to the CITY if your insurance company elects to cancel or materially reduce coverage or limits prior to the policy expiration date, for any reason except impairment of an aggregate limit due to prior claims.

3. Primary Coverage. CONTRACTOR will provide coverage that is primary with respect to any insurance or self-insurance of the CITY. The CITY'S program shall be excess of this insurance and non-contributing.

4. Modification of Coverage. The CITY reserves the right at any time during the term of this Contract to change the amounts and types of insurance required hereunder by giving CONTRACTOR ninety (90) days' advance written notice of such change. If such change should result in substantial additional cost to CONTRACTOR, the CITY agrees to negotiate additional compensation proportional to the increased benefit to the CITY.

5. Failure to Procure Insurance. All required insurance must be submitted and approved by the Office of the City Administrative Officer, Risk Management prior to the inception of any operations by CONTRACTOR.

CONTRACTOR'S failure to procure or maintain required insurance or a self-insurance program during the entire term of this Contract shall constitute a material breach of this Contract under which the CITY may immediately suspend or terminate this Contract or, at its discretion, procure or renew such insurance to protect the CITY'S interests and pay any and all premiums in connection therewith and recover all monies so paid from CONTRACTOR.

6. Workers' Compensation. By signing this Contract, CONTRACTOR hereby certifies that it is aware of the provisions of Section 3700 *et seq.*, of the California Labor Code which require every employer to be insured against liability for Workers' Compensation or to undertake

self-insurance in accordance with the provisions of that Code, and that it will comply with such provisions at all time during the performance of the work pursuant to this Contract.

7. California Licensee. All insurance must be provided by an insurer admitted to do business in California or written through a California-licensed surplus lines broker or through an insurer otherwise acceptable to the CITY. Non-admitted coverage must contain a **Service of Suit** clause in which the underwriters agree to submit as necessary to the jurisdiction of a California court in the event of a coverage dispute. Service of process for this purpose must be allowed upon an agent in California designated by the insurer or upon the California Insurance Commissioner.

8. Aggregate Limits/Impairment. If any of the required insurance coverages contain annual aggregate limits, CONTRACTOR must give the CITY written notice of any pending claim or lawsuit which will materially diminish the aggregate within thirty (30) days of knowledge of same. You must take appropriate steps to restore the impaired aggregates or provide replacement insurance protection within thirty (30) days of knowledge of same. The CITY has the option to specify the minimum acceptable aggregate limit for each line of coverage required. No substantial reductions in scope of coverage which may affect the CITY'S protection are allowed without the CITY'S prior written consent.

9. Commencement of Work. For purposes of insurance coverage only, this Contract will be deemed to have been executed immediately upon any party hereto taking any steps that can be considered to be in furtherance of or towards performance of this Contract. The requirements in this Section supersede all other sections and provisions of this Contract, including, but not limited to, PSC-4, to the extent that any other section or provision conflicts with or impairs the provisions of this Section.

Exhibit 1 (Continued) Required Insurance and Minimum Limits

Name: _____ Date: _____

Agreement/Reference: _____

Evidence of coverages checked below, with the specified minimum limits, must be submitted and approved prior to occupancy/start of operations. Amounts shown are Combined Single Limits ("CSLs"). For Automobile Liability, split limits may be substituted for a CSL if the total per occurrence equals or exceeds the CSL amount.

Limits

Workers' Compensation – Workers' Compensation (WC) and Employer's Liability (EL)	WC	<u>Statutory</u>
	EL	_____
<input type="checkbox"/> Waiver of Subrogation in favor of City	<input type="checkbox"/> Longshore & Harbor Workers	
	<input type="checkbox"/> Jones Act	

General Liability _____

<input type="checkbox"/> Products/Completed Operations	<input type="checkbox"/> Sexual Misconduct _____
<input type="checkbox"/> Fire Legal Liability _____	
<input type="checkbox"/> _____	

Automobile Liability (for any and all vehicles used for this Contract, other than commuting to/from work) _____

Professional Liability (Errors and Omissions) _____

Property Insurance (to cover replacement cost of building – as determined by insurance company) _____

<input type="checkbox"/> All Risk Coverage	<input type="checkbox"/> Boiler and Machinery
<input type="checkbox"/> Flood _____	<input type="checkbox"/> Builder's Risk
<input type="checkbox"/> Earthquake _____	<input type="checkbox"/> _____

Pollution Liability _____

Surety Bonds – Performance and Payment (Labor and Materials) Bonds 100 % of Contract Price

Crime Insurance _____

Other: _____

RFP EXHIBIT F
PROFORMA FINANCIAL STATEMENTS SUBMITTAL FORM
OPERATION AND MAINTENANCE OF THE GREEK THEATRE FOOD AND BEVERAGE CONCESSION (CON-XXX-XXX)

Proposer

	Operating Proforma - By Contract Year		
	1	2	3
Revenue:			
Food and Non-Alc Beverage Sales	\$ -	\$ -	\$ -
Alcoholic Beverage Sales	\$ -	\$ -	\$ -
Mobile Food Service	\$ -	\$ -	\$ -
Other	\$ -	\$ -	\$ -
Total Revenue:	\$ -	\$ -	\$ -
Cost of Goods			
Gross Margin	\$ -	\$ -	\$ -
Gross Margin %	#DIV/0!	#DIV/0!	#DIV/0!
Expenses:			
Rent			
Related Equipment	\$ -	\$ -	\$ -
Food and Non-Alc Beverage Sales	\$ -	\$ -	\$ -
Alcoholic Beverage Sales	\$ -	\$ -	\$ -
Other	\$ -	\$ -	\$ -
Total Rent:	\$ -	\$ -	\$ -
Payroll Costs			
Wages			
Payroll Taxes			
Health Insurance & Benefits			
Workers' Compensation Insurance			
Total Payroll Costs	\$ -	\$ -	\$ -
Variable Costs			
Accounting			
Advertising, Marketing & Promotion			
Dues & Subscriptions			
Environmental Costs			
Equipment Replacement - Small			
Equipment Replacement - Large			
Legal			
Office Expenses			
Payroll Processing Fees			
Professional Services			
Repair & Maint. - FF&E			
Repair & Maint. - Building			
Supplies			
Start up Expenses - Yr 1			
Telephone			
Travel & Entertainment			
Utilities			
Other			
Total Variable Expenses	\$ -	\$ -	\$ -
Proposer			
Fixed Costs			
Depreciation			
Insurance & Liability			
Service Contracts			
Licenses			
Other			
Total Fixed Expenses	\$ -	\$ -	\$ -
Total Operating Expenses:	\$ -	\$ -	\$ -
Profit Before Interest and Taxes	\$ -	\$ -	\$ -
Debt Expense			
Taxes			
Other			
Net Profit:	\$ -	\$ -	\$ -
Break Even Analysis	\$ -	\$ -	\$ -

Required Insurance and Minimum Limits

Name: Greek Theatre Food & Beverage Concession RFP

Date: 04/08/2015

Agreement/Reference: _____

Evidence of coverages checked below, with the specified minimum limits, must be submitted and approved prior to occupancy/start of operations. Amounts shown are Combined Single Limits ("CSLs"). For Automobile Liability, split limits may be substituted for a CSL if the total per occurrence equals or exceeds the CSL amount.

Limits

Workers' Compensation - Workers' Compensation (WC) and Employer's Liability (EL)

WC Statutory

EL \$1,000,000

Waiver of Subrogation in favor of City

Longshore & Harbor Workers

Jones Act

General Liability _____ \$5,000,000

Products/Completed Operations

Sexual Misconduct _____

Fire Legal Liability \$100,000 _____

Liquor Liability \$1,000,000 _____

Rental Interruption 180 days

Automobile Liability (for any and all vehicles used for this contract, other than commuting to/from work) \$1,000,000

____ **Professional Liability** (Errors and Omissions) _____

Discovery Period 12 Months After Completion of Work or Date of Termination

____ **Property Insurance** (to cover replacement cost of building - as determined by insurance company) _____

All Risk Coverage

Boiler and Machinery

Flood _____

Builder's Risk

Earthquake _____

____ **Pollution Liability** _____

____ **Surety Bonds - Performance and Payment (Labor and Materials) Bonds** 100% of the contract price

____ **Crime Insurance** _____

Other: _____

CITY OF LOS ANGELES

INSTRUCTIONS AND INFORMATION
ON COMPLYING WITH CITY INSURANCE REQUIREMENTS

(Share this information with your insurance agent or broker)

1. **Agreement/Reference** All evidence of insurance must identify the nature of your business with the CITY. Clearly show any assigned number of a bid, contract, lease, permit, etc. or give the project name and the job site or street address to ensure that your submission will be properly credited. Provide the **types of coverage and minimum dollar amounts** specified on the Required Insurance and Minimum Limits sheet (Form Gen. 146) included in your CITY documents.

2. **When to submit** Normally, no work may begin until a CITY insurance certificate approval number ("CA number") has been obtained, so insurance documents should be submitted as early as practicable. For **As-needed Contracts**, insurance need not be submitted until a specific job has been awarded. **Design Professionals** coverage for new construction work may be submitted simultaneously with final plans and drawings, but before construction commences.

3. **Acceptable Evidence and Approval** Electronic submission is the best method of submitting your documents. **Track4LA**[®] is the CITY's online insurance compliance system and is designed to make the experience of submitting and retrieving insurance information quick and easy. The system is designed to be used by insurance brokers and agents as they submit client insurance certificates directly to the City. It uses the standard insurance industry form known as the **ACORD 25 Certificate of Liability Insurance** in electronic format – the CITY is a licensed redistributor of ACORD forms. Track4LA[®] advantages include standardized, universally accepted forms, paperless approval transactions (24 hours, 7 days per week), and security checks and balances. The easiest and quickest way to obtain approval of your insurance is to have your insurance broker or agent access **Track4LA**[®] at <http://track4la.lacity.org> and follow the instructions to register and submit the appropriate proof of insurance on your behalf.

Insurance industry certificates other than the ACORD 25 that have been approved by the State of California may be accepted, however ***submissions other than through Track4LA[®] will significantly delay the insurance approval process as documents will have to be manually processed.*** All Certificates must provide a thirty (30) days' cancellation notice provision (ten (10) days for non-payment of premium) AND an Additional Insured Endorsement naming the CITY an additional insured completed by your insurance company or its designee. If the policy includes an automatic or blanket additional insured endorsement, the Certificate must state the CITY is an automatic or blanket additional insured. An endorsement naming the CITY an Additional Named Insured and Loss Payee as Its Interests May Appear is required on property policies. All evidence of insurance must be authorized by a person with authority to bind coverage, whether that is the authorized agent/broker or insurance underwriter. Completed **Insurance Industry Certificates other than ACORD 25 Certificates** are sent electronically to CAO.insurance.bonds@lacity.org.

Additional Insured Endorsements DO NOT apply to the following:

- Indication of compliance with statute, such as Workers' Compensation Law.
- Professional Liability insurance.

Verification of approved insurance and bonds may be obtained by checking **Track4LA**[®], the CITY's online insurance compliance system, at <http://track4la.lacity.org>.

4. **Renewal** When an existing policy is renewed, have your insurance broker or agent submit a new Acord 25 Certificate or edit the existing Acord 25 Certificate through **Track4LA**[®] at <http://track4la.lacity.org>.

5. **Alternative Programs/Self-Insurance** Risk financing mechanisms such as Risk Retention Groups, Risk Purchasing Groups, off-shore carriers, captive insurance programs and self-insurance programs are subject to separate approval after the CITY has reviewed the relevant audited financial statements. To initiate a review of your program, you should complete the Applicant's Declaration of Self Insurance form (<http://cao.lacity.org/risk/InsuranceForms.htm>) to the Office of the City Administrative Officer, Risk Management for consideration.

6. **General Liability** insurance covering your operations (and products, where applicable) is required whenever the CITY is at risk of third-party claims which may arise out of your work or your presence or special event on City premises. **Sexual Misconduct** coverage is a required coverage when the work performed involves minors. **Fire Legal Liability** is required for persons occupying a portion of CITY premises. Information on two CITY insurance programs, the SPARTA program, an optional source of low-cost insurance which meets the most minimum requirements, and the Special Events Liability Insurance Program, which provides liability coverage for short-term special events on CITY premises or streets, is available at (www.2sparta.com), or by calling (800) 420-0555.

7. **Automobile Liability** insurance is required only when vehicles are used in performing the work of your Contract or when they are driven off-road on CITY premises; it is not required for simple commuting unless CITY is paying mileage. However, compliance with California law requiring auto liability insurance is a contractual requirement.

8. **Errors and Omissions** coverage will be specified on a project-by-project basis if you are working as a licensed or other professional. The length of the claims discovery period required will vary with the circumstances of the individual job.

9. **Workers' Compensation and Employer's Liability** insurance are not required for single-person contractors. However, under state law these coverages (or a copy of the state's Consent To Self Insure) must be provided if you have any employees at any time during the period of this contract. Contractors with no employees must complete a Request for Waiver of Workers' Compensation Insurance Requirement (<http://cao.lacity.org/risk/InsuranceForms.htm>). **A Waiver of Subrogation** on the coverage is required only for jobs where your employees are working on CITY premises under hazardous conditions, e.g., uneven terrain, scaffolding, caustic chemicals, toxic materials, power tools, etc. The Waiver of Subrogation waives the insurer's right to recover (from the CITY) any workers' compensation paid to an injured employee of the contractor.

10. **Property Insurance** is required for persons having exclusive use of premises or equipment owned or controlled by the CITY. **Builder's Risk/Course of Construction** is required during construction projects and should include building materials in transit and stored at the project site.

11. **Surety** coverage may be required to guarantee performance of work and payment to vendors and suppliers. A **Crime Policy** may be required to handle CITY funds or securities, and under certain other conditions. **Specialty coverages** may be needed for certain operations. For assistance in obtaining the CITY required bid, performance and payment surety bonds, please see the City of Los Angeles Bond Assistance Program website address at <http://cao.lacity.org/risk/BondAssistanceProgram.pdf> or call (213) 258-3000 for more information.



City Ethics Commission
 200 N Spring Street
 City Hall — 24th Floor
 Los Angeles, CA 90012
 Mail Stop 129
 (213) 978-1960

Prohibited Contributors (Bidders)

CEC Form 55

This form must be completed in its entirety and submitted to the awarding authority with your bid or proposal for the contract noted below. A bid or proposal that does not include a completed form will be deemed nonresponsive. Please write legibly.

Original filing Amended filing (original signed on _____; last amendment signed on _____)

Bid/Contract/BAVN Number (or other identifying information if no number):

Date Bid Submitted:

Description of Contract:

Awarding Authority (Department):

BIDDER

Name: _____

Address: _____

Email (optional): _____ Phone: _____

State Contractor ID: _____

State ID must be disclosed for identification purposes, even if not performing work on this contract under that license. If the bidder does not have a state contractor ID, indicate "not applicable".

PRINCIPALS

Please identify the names and titles of all principals (attach additional sheets if necessary). Principals include a bidder's board chair, president, chief executive officer, chief operating officer, and individuals who serve in the functional equivalent of one or more of those positions. Principals also include individuals who hold an ownership interest in the bidder of at least 20 percent and employees of the bidder who are authorized by the bid or proposal to represent the bidder before the City.

Name: _____ Title: _____

Address: _____

Name: _____ Title: _____

Address: _____

Name: _____ Title: _____

Address: _____

Name: _____ Title: _____

Address: _____

_____ additional sheets are attached. Bidder is an individual and no other principals exist.



City Ethics Commission
200 N Spring Street
City Hall — 24th Floor
Los Angeles, CA 90012
Mail Stop 129
(213) 978-1960

Prohibited Contributors (Bidders) CEC Form 55

SUBCONTRACTORS

Please identify all subcontractors whose subcontracts are worth \$100,000 or more (attach additional sheets if necessary). If the subcontractor has a state contractor license, the ID must be disclosed for identification purposes, even if the subcontractor is not performing work on this contract under that license.

Subcontractor: _____
Address: _____
State Contractor ID (for identification purposes; if none, indicate "not applicable"): _____

Subcontractor: _____
Address: _____
State Contractor ID (for identification purposes; if none, indicate "not applicable"): _____

Subcontractor: _____
Address: _____
State Contractor ID (for identification purposes; if none, indicate "not applicable"): _____

Subcontractor: _____
Address: _____
State Contractor ID (for identification purposes; if none, indicate "not applicable"): _____

Subcontractor: _____
Address: _____
State Contractor ID (for identification purposes; if none, indicate "not applicable"): _____

Subcontractor: _____
Address: _____
State Contractor ID (for identification purposes; if none, indicate "not applicable"): _____

Subcontractor: _____
Address: _____
State Contractor ID (for identification purposes; if none, indicate "not applicable"): _____

Subcontractor: _____
Address: _____
State Contractor ID (for identification purposes; if none, indicate "not applicable"): _____

Subcontractor: _____
Address: _____
State Contractor ID (for identification purposes; if none, indicate "not applicable"): _____

_____ additional sheets are attached.

Bidder has no subcontractors on this bid or proposal whose subcontracts are worth \$100,000 or more.



City Ethics Commission
 200 N Spring Street
 City Hall — 24th Floor
 Los Angeles, CA 90012
 Mail Stop 129
 (213) 978-1960

Prohibited Contributors (Bidders)

CEC Form 55

PRINCIPALS OF SUBCONTRACTORS

Please identify the names and titles of all principals for each subcontractor identified on page 2 (attach additional sheets if necessary). Principals include a subcontractor's board chair, president, chief executive officer, chief operating officer, and individuals who serve in the functional equivalent of one or more of those positions. Principals also include individuals who hold an ownership interest in the subcontractor of at least 20 percent and employees of the subcontractor who are authorized by the bid or proposal to represent the subcontractor before the City.

Name: _____ Title: _____

Address: _____

Subcontractor: _____

Name: _____ Title: _____

Address: _____

Subcontractor: _____

Name: _____ Title: _____

Address: _____

Subcontractor: _____

Name: _____ Title: _____

Address: _____

Subcontractor: _____

Name: _____ Title: _____

Address: _____

Subcontractor: _____

Of the subcontractors identified on page 2, the following are individuals and no other principals exist (attach additional sheets if necessary):

Subcontractor: _____

Subcontractor: _____

_____ additional sheets are attached.

Bidder has no subcontractors on this bid or proposal whose subcontracts are worth \$100,000 or more.

CERTIFICATION

I certify that I understand, will comply with, and have notified my principals and subcontractors of the requirements and restrictions in Los Angeles City Charter section 470(c)(12) and any related ordinances. I understand that I must amend this form within ten business days if the information above changes. I certify under penalty of perjury under the laws of the City of Los Angeles and the state of California that the information provided above is true and complete.

Date: _____ Signature: _____

Name: _____

Title: _____

Under Los Angeles City Charter § 470(c)(12), this form must be submitted to the awarding authority with your bid or proposal. A bid or proposal that does not include a completed Form 55 will be deemed nonresponsive.

ORDINANCE NO. 179281

An ordinance amending Los Angeles Administrative Code to add a new Division 10, Chapter 1, Article 18 to establish a program that requires service contractors who hire new employees to perform work on a City contract to seek employee references through referrals from the City and other agencies interested in training and finding employment for the traditionally unemployed or under-employed.

**THE PEOPLE OF THE CITY OF LOS ANGELES
DO ORDAIN AS FOLLOWS:**

Section 1. A new Article 18 is added to Chapter 1 of Division 10 of the Los Angeles Administrative Code to read:

**CHAPTER 1, ARTICLE 18
FIRST SOURCE HIRING****Sec. 10.44. Purpose.**

The City awards many contracts to private firms to provide services to the public and to City government. The City also provides grant and loan funding to others for the purpose of economic development or job growth. The City expends grant funds under programs created by the federal and state governments, which promote the goals established for those programs and similar goals of the City. The City intends that the policies underlying this article serve to guide all of these expenditures to the extent allowed by the law.

City service contracts are subject to the City's Living Wage ordinance and provide covered workers with substantially greater wages and benefits than otherwise required by law. In addition, having the opportunity to work on a City contract affords workers valuable experience that can be used to garner future employment. The City has an interest in expanding the field of competent service workers to address the problems associated with a significant local unemployed, under-employed and unskilled workforce. The City serves this interest by expanding the opportunities that workers have to be referred for employment by City contractors.

The inadequate compensation often paid to service workers who are not subject to the City's living wage requirements fails to provide those workers with resources sufficient to afford life in Los Angeles. Further, there are many unemployed and under-employed service workers who are interested in performing work on City contracts. Young people constitute a significant portion of the unemployed and under-employed. Experience indicates that unemployment and under-employment contribute to devastating social burdens including a sustained, large population of unskilled workers, increased crime and increased need for costly social services. The City, as a principal provider of social support services, has an interest in promoting an employment environment that protects such limited resources. In creating a program that helps link

Contractors with potential service workers, the City serves this interest and provides greater opportunities for employment on service contracts. To further serve this interest, the Library Department and the Department of Recreation and Parks are encouraged to adopt policies consistent with this article.

Sec. 10.44.1. Definitions.

The following definitions shall apply throughout this article:

“Awarding Authority” means any subordinate or component entity or person of the City, such as a department or Board of Commissioners that has the authority to award or enter into any a Contract (as defined below). This shall not include any department that has control of its own funds or the Community Redevelopment Agency.

“CDD” means the City Community Development Department’s Workforce Development System.

“City” means the City of Los Angeles, a municipal corporation, and all City Awarding Authorities.

“Contract” means a contract, which is in excess of \$25,000 with a term greater than three months, awarded to a Contractor by the City or by a Loan or Grant Recipient primarily to furnish services to or for the City or the Loan or Grant Recipient. This shall not include construction contracts for a public work of improvement.

“Contractor” means any Person that enters into a Contract with the City or a Loan or Grant Recipient.

“Designated Administrative Agency” or **“DAA”** means the Department of Public Works, Bureau of Contract Administration, who shall bear administrative responsibilities under this article.

“Loan or Grant Recipient” means any person who receives from the City a qualifying grant or loan for economic development or job growth expressly articulated and identified by the City.

“Person” means any individual, proprietorship, partnership, joint venture, corporation, Limited Liability Company, trust, association, or other entity that may employ individuals or enter into contracts.

“Referral Resources” means any resource used to locate new employees considered for employment under this article. Referral Resources shall include Trade Unions, Community Based Organizations, City Work Source Centers and any other resources approved by CDD.

“Subcontractor” means any person that enters into a contract with a Contractor or Subcontractor to assist in performing the services to the City or the Loan or Grant Recipient.

Sec. 10.44.2. First Source Hiring Procedure.

(a) Before executing a Contract, each Awarding Authority shall receive from the Contractor and provide to the DAA a list of anticipated employment opportunities that Contractor and its Subcontractors estimate they will need to fill in order to perform the services under the Contract. The list shall include:

(1) The number of anticipated employment opportunities throughout the term of the Contract; and

(2) The job title and description of each anticipated employment opportunity; and

(3) The basic qualifications necessary for each anticipated employment opportunity; and

(4) The number of anticipated hires made subject to the Service Contract Worker Retention Ordinance.

(b) During the term of the Contract, Contractor shall:

(1) At least seven business days prior to making an announcement of a specific employment opportunity, provide notifications of that employment opportunity to the CDD, which will refer individuals for interview; and

(2) Interview qualified individuals referred by Referral Resources; and

(3) Prior to filling any employment opportunity, the Contractor shall inform the DAA of the names of the Referral Resources used, the names of the individuals they referred, the names of the referred individuals who the Contractor or Subcontractor interviewed and the reasons why referred individuals were not hired.

(c) Managerial, supervisory or confidential positions shall not be subject to this article.

(d) Positions requiring professional licenses to perform the Contract shall not be subject to this article.

Sec. 10.44.3. City Loan or Grant Recipients.

(a) A City Loan or Grant Recipient is subject to this article if the loan or grant is for economic development or job growth, is in an aggregate amount that exceeds \$25,000 and either:

(1) The loan is provided at an interest rate below the applicable federal rate as used in 26 U.S.C. Sections 1274(d), 7872(f) at the time the Contract is executed; or

(2) The loan is at or above the applicable federal rate but the loan provides a mechanism for forgiving the interest.

(b) In the event that the applicable federal rate falls below the rate at which a City Loan is provided during the term of the Contract, the Awarding Authority may request the DAA to waive the requirements of this article.

Sec. 10.44.4. Compliance with the Service Contractor Worker Retention Ordinance.

Where applicable, Contractor shall first comply with the Service Contractor Worker Retention Ordinance, Administrative Code Section 10.36 *et seq.*, as amended from time to time.

Sec. 10.44.5. Designation of a Liaison.

Prior to execution of the Contract, Contractor shall provide the City with the name and contact information of the liaison designated to work with the DAA to implement this article.

Sec. 10.44.6. Transfer and Promotion.

This article does not prevent a Contractor from filling job vacancies or newly created positions by transfer or promotion of its existing staff.

Sec. 10.44.7. Administration.

(a) The DAA shall promulgate rules and regulations to assure efficient implementation and enforcement of this article.

(b) The DAA may delegate duties to other City departments and provide for the manner in which exemptions from this article are approved and documented.

(c) The DAA shall develop the forms to be used by the Awarding Authorities toward implementing this article.

(d) The DAA may establish rules and guidelines governing pre-interview screening of individuals referred under this article.

(e) The DAA shall investigate alleged violations of this article and monitor compliance with this article.

(f) The DAA may establish by regulation provisions under which the DAA may exempt a Contractor from the requirements of this article for specific employment opportunities.

(g) The DAA shall report to the Ad Hoc Committee on Gang Violence and Youth Development quarterly for one year after the ordinance is adopted. After the first year, the frequency of reporting requirements shall be determined by the DAA, or as otherwise instructed by City Council.

Sec. 10.44.8. Enforcement.

If the DAA determines that a Contractor has violated this article, the DAA may recommend that the Awarding Authority take any of the following actions:

(a) Document the determination in the Awarding Authority's Contractor Evaluation required under Los Angeles Administrative Code Section 10.39 *et seq.*; and

(b) Require that the Contractor document the determination in each of the Contractor's subsequent Contractor Responsibility Questionnaires submitted under Los Angeles Administrative Code Section 10.40 *et seq.*; and

(c) Terminate the Contract.

The Awarding Authority may pursue any rights and remedies available by law.

Sec. 10.44.9. Exemptions.

Upon request of the Awarding Authority, the DAA shall determine whether a Contract is exempt from this article because any of the following is applicable:

(a) Contracts where the provisions of this article conflict with federal or state law.

(b) Contracts with another governmental entity.

(c) Contracts where the provisions of this article would conflict with federal or state grant funded contracts, or conflict with the terms of the grant or subvention.

(d) Contracts awarded under urgent or emergency circumstances.

(e) Contracts entered into pursuant to Charter Section 371(e)(7).

(f) Contracts where the services are available only from a single source.

(g) Contracts that involve the investment of trust monies, bond proceeds or agreements relating to the management of these funds, indentures, security enhancement agreements (including, but not limited to, liquidity agreements, letters of credit and bond insurance) for City tax-exempt and taxable financings, deposits of City's surplus funds in financial institutions, the investment of City monies in competitively bid investment agreements, the investment of City monies in securities permitted under the California State Government Code or the City's investment policy, investment agreements, repurchase agreements, City monies invested in U.S. government securities or pre-existing investment agreements.

(h) Contracts involving City monies if the Treasurer or the City Administrative Officer finds that failure to enter into the Contract will violate his or her fiduciary duties and cause the City to incur a financial loss or forego a financial benefit.

(i) City Loans or Grants funded from the proceeds of a bond issuance, tax credits or tax increment financing.

Sec. 10.44.10. Application of this Article.

This article is applicable to Contracts and amendments to Contracts entered into after the rules and regulations have been promulgated by the DAA.

Sec. 10.44.11. No Third Party Beneficiary.

This article does not create beneficial interests in any person who is not a party to the Contract.

Sec. 10.44.12. Coexistence with Other Available Relief for Specific Deprivations of Protected Rights.

This article shall not be construed to limit a person's right to bring legal action for violation of other laws.

Sec. 10.44.13. Intentional Violation. If the DAA determines that a Contractor intentionally violated the ordinance or used hiring practices for the purpose of avoiding this article, the determination must be documented in the Awarding Authority's Contractor Evaluation, required under Los Angeles Administrative Code Section 10.39 *et seq.*, and must be documented in each of the Contractor's subsequent Contractor Responsibility Questionnaires submitted under Los Angeles Administrative Code Section 10.40 *et seq.* This measure does not limit the City's authority to act under this article.

Sec. 10.44.14. Severability.

If a court of competent jurisdiction finds any provision of this article invalid, the remaining provisions shall remain in full force and effect.

Sec. 2. The City Clerk shall certify to the passage of this ordinance and have it published in accordance with Council policy, either in a daily newspaper circulated in the City of Los Angeles or by posting for ten days in three public places in the City of Los Angeles: one copy on the bulletin board located at the Main Street entrance to the Los Angeles City Hall; one copy on the bulletin board located at the Main Street entrance to the Los Angeles City Hall East; and one copy on the bulletin board located at the Temple Street entrance to the Los Angeles County Hall of Records.

I hereby certify that this ordinance was passed by the Council of the City of Los Angeles, at its meeting of OCT 03 2007.

FRANK T. MARTINEZ, City Clerk

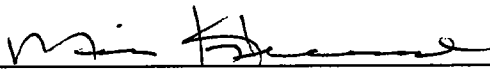
By 
Deputy

Approved OCT 19 2007

Mayor

Approved as to Form and Legality

ROCKARD J. DELGADILLO, City Attorney

By 
DAVID MICHAELSON
Chief Assistant City Attorney

Date 10/1/07

File No. 06-2443

DECLARATION OF POSTING ORDINANCE

I, MARIA C. RICO, state as follows: I am, and was at all times hereinafter mentioned, a resident of the State of California, over the age of eighteen years, and a Deputy City Clerk of the City of Los Angeles, California.

Ordinance No. 179281 - Amending Los Angeles Administrative Code to add a new Division 10, Chapter 1, Article 18 - a copy of which is hereto attached, was finally adopted by the Los Angeles City Council on **October 3, 2007**, and under the direction of said City Council and the City Clerk, pursuant to Section 251 of the Charter of the City of Los Angeles and Ordinance No. 172959, on **October 24, 2007** I posted a true copy of said ordinance at each of three public places located in the City of Los Angeles, California, as follows: 1) one copy on the bulletin board located at the Main Street entrance to the Los Angeles City Hall; 2) one copy on the bulletin board located at the Main Street entrance to the Los Angeles City Hall East; 3) one copy on the bulletin board located at the Temple Street entrance to the Hall of Records of the County of Los Angeles.

Copies of said ordinance were posted conspicuously beginning on **October 24, 2007** and will be continuously posted for ten or more days.

I declare under penalty of perjury that the foregoing is true and correct.

Signed this **24th** day of **October 2007** at Los Angeles, California.

Maria C. Rico, Deputy City Clerk

Ordinance Effective Date: December 3, 2007

Council File No. 06-2443

GOOD FOOD PURCHASING POLICY

In accordance with Mayor's Executive Directive No. 24, "Good Food Purchasing Policy," proposers are required to comply with the City of Los Angeles' Good Food Purchasing Guidelines.

The purpose of the policy is to make Good Food (defined as "food that is healthy, affordable, fair, and sustainable") more widely available to all Angelenos in order to promote healthier eating habits, support our local business economy, and create more jobs along the food supply chain. The Good Food Purchasing Guidelines (Guidelines) emphasize five core values: Local Economies, Environmental Sustainability, Valued Workforce, Animal Welfare, and Nutrition. The complete Guidelines are included in this exhibit.

All Bidders/Proposers who are awarded contracts with the Department shall complete and submit the Good Food Purchasing Pledge (one [1] page) prior to execution of the contract.

INSTRUCTIONS:

- a. Awarded proposer only: Complete, submit, and comply with the steps outlined in the Good Food Purchasing Pledge (Page 1 of attached informational package).

The Good Food Purchasing Pledge



IN PLEDGING OUR SUPPORT FOR GOOD FOOD, we will use our purchasing power to encourage the production and consumption of food that is healthy, affordable, fair, and sustainable. We recognize that the adoption of food procurement policies has the power to reform the food system, create opportunities for smaller farmers to thrive, provide just compensation and fair treatment for workers, support sustainable farming practices, reward good environmental stewardship, and increase access to fresh and healthy foods.

We pledge to leverage our purchasing power to support the following values:

- **Local Economies:** support small and mid-sized agricultural and food processing operations within the local area or region.
- **Environmental Sustainability:** source from producers that employ sustainable production systems that reduce or eliminate synthetic pesticides and fertilizers; avoid the use of hormones, antibiotics, and genetic engineering; conserve soil and water; protect and enhance wildlife habitat and biodiversity; and reduce on-farm energy consumption and greenhouse gas emissions.
- **Valued Workforce:** provide safe and healthy working conditions and fair compensation to all food chain workers and producers, from production to consumption.
- **Animal Welfare:** provide healthy and humane care for livestock.
- **Nutrition:** promote health and well-being by offering generous portions of vegetables, fruit, and whole grains; reducing salt, added sugars, fats, and oils; and by eliminating artificial additives.

Signed by _____

Signature _____

Title _____

Name of Institution _____

Date _____

WE COMMIT OUR INSTITUTION TO TAKING THE FOLLOWING STEPS IN SUPPORT OF GOOD FOOD:

1

As outlined in the *Good Food Purchasing Guidelines for Food Service Institutions*, we commit to **annually increasing our procurement of Good Food** to meet multi-year benchmarks at the baseline level or beyond for five value categories – local economies, environmental sustainability, valued workforce, animal welfare, and nutrition.

2

Establish supply chain accountability and a traceability system with vendors/distributors to verify sourcing commitments, assess current food procurement practices, and compile assessment results in a progress report.

3

Report annually on implementation progress of the *Good Food Purchasing Guidelines*.

TO GUIDE IMPLEMENTATION, WE COMMIT TO THE FOLLOWING TIMELINE:

1

Complete a baseline *Good Food Purchasing* survey within one month of signing the *Good Food Purchasing Pledge*.

2

Communicate Good Food commitment to all suppliers, including distributors and food service companies within one month of the adoption of the *Good Food Purchasing Pledge*.

3

Complete an assessment of food purchasing practices within six months of the adoption of the *Good Food Purchasing Pledge*.

4

Develop and adopt a multi-year action plan with benchmarks to comply with the *Good Food Purchasing Guidelines* within the first year of the adoption to the *Good Food Purchasing Pledge* and share action plans with the Los Angeles Food Policy Council.

5

Incorporate the *Good Food Purchasing Guidelines for Food Service Institutions* into new RFPs and contracts, where applicable.

PROGRAM COMPONENTS

- **Multi-Year Benchmarks:** Purchasers are asked to meet benchmarks in years one and five, recognizing that the shift towards Good Food purchasing will take time, and purchasers will need to make incremental changes.
- **Tiered-Value System:** A tiered-value system has been developed to evaluate the potential contribution of purchases to a Good Food Purchasing initiative. For each of the five values, foods are ranked from Level One (baseline) through Level Three (highest). Higher tiers of achievement are rewarded with more points accordingly.
- **Ranked Criteria:** For most value categories, third-party certifications and label claims allowed by USDA or FDA are used to determine the level of “Good” achieved by an institution’s purchases. These third-party certifications are used to rank Good Food purchases as Levels One (baseline), Two, or Three within each value category.
- **Baseline Requirements:** A baseline in each category is established that must be maintained throughout participation in the program.
- **Good Food Recognition:** Purchasers are scored and recognized at different levels to reward higher Good Food sourcing commitments within value categories. Purchasers that meet the baseline level for each category receive Good Food Purchaser recognition (one star). Additional levels (two to five stars) are awarded to purchasers to recognize the most dedicated supporters of the *Good Food Purchasing Guidelines*.
- **Traceability:** Purchasers are asked to work with suppliers to establish transparent reporting systems to verify product source.
- **Compliance Plan:** If vendor and/or suppliers do not have a current capacity to meet food purchasing targets, the vendor may submit a plan to achieve full compliance at a baseline level by the end of year one.
- **Annual Report:** Purchasers are asked to report annually on their progress.
- **Promotion:** The City of Los Angeles and the Los Angeles Food Policy Council will regularly promote and celebrate Good Food institutional commitments. Successful participants in the *Good Food Purchasing Pledge* program can also serve as an inspiration and positive role model for other institutions in our region.

PROGRAM OVERVIEW: GOOD FOOD PURCHASING GUIDELINES

Los Angeles Food Policy Council (LAFPC), in collaboration with public, private, and non-profit partners, developed *Good Food Purchasing Guidelines*, model guidelines for food service establishments in assessing and purchasing Good Food — food that is healthy, affordable, fair, and sustainable.

Scaled similarly to LEED green building certification, the *Good Food Purchasing Guidelines* emphasize five key values:

- (1) Local Economies
- (2) Environmental Sustainability
- (3) Valued Workforce
- (4) Animal Welfare
- (5) Nutrition

About the Los Angeles Food Policy Council

The Los Angeles Food Policy Council (LAFPC) is a collective impact initiative created by Mayor Antonio Villaraigosa in January of 2011. LAFPC’s mission is to build a Good Food system for all Los Angeles residents. Such a system ensures that food is healthy, affordable, fair, and sustainable in order to improve the health and well-being of our residents, particularly in low-income communities and communities of color; promotes a thriving Good Food economy for everyone; and strengthens agricultural and environmental stewardship throughout the region. LAFPC coordinates the expertise and leadership of public, private, nonprofit, and academic partners to strengthen connections across the food system. The Food Policy Council and its staff serve as the “backbone” organization for the initiative, which has an extended reach of approximately 300 individuals and over 150 organizations.

LAFPC leverages its unique structure and placement as an independent multi-stakeholder initiative within the Mayor’s Office to advance innovative food policies. LAFPC combines coalition-building, leadership development, and issue and policy advocacy to advance food policies and programmatic innovations. The council’s goal is to shift our regional food system to promote local growers, sustainable agriculture, and fair working conditions for all food workers, and to ensure access to healthy affordable food in underserved communities.

For more information, contact info@goodfoodla.org.

**Good Food
Purchasing Guidelines
for
Food Service Institutions**

**Los Angeles
Food Policy Council**



**LOS ANGELES
FOOD POLICY
COUNCIL**

**Good Food
Purchasing Guidelines
for
Food Service Institutions**

**Los Angeles
Food Policy Council**



**LOS ANGELES
FOOD POLICY
COUNCIL**

October 2012

GOODFOODLA.ORG

Los Angeles Food Policy Council

Martin Anenberg	FreshPoint Southern California
Andrea Azuma	Community Benefit, Kaiser Permanente Southern California
David Binkle	Food Services Division, Los Angeles Unified School District
Omar Brownson	Los Angeles River Revitalization Corporation
Glen Dake	Los Angeles Community Garden Council
Paula Daniels	Office of Mayor Villaraigosa, City of Los Angeles
Michael Flood	Los Angeles Regional Food Bank
Gwendolyn Flynn	Community Health Councils
Robert Gottlieb	Urban & Environmental Policy Institute, Occidental College
Renee Guilbault	Pret A Manger
Glenda Humiston	California Rural Development, U.S. Department of Agriculture
Helena Jubany	Fresco Community Market
AG Kawamura	Orange County Produce
Gregg Kettles	Office of Mayor Villaraigosa, City of Los Angeles
Evan Kleiman	Good Food, KCRW
Amy Knoll Fraser	Grace + BLD Restaurants
Mary M. Lee	PolicyLink
Miguel Luna	Urban Semillas
Phil McGrath	McGrath Family Farms
Roman Pinal	United Farm Workers
Michael Roberts	Center for Food Law & Policy, UCLA School of Law
Bruce Saito	Los Angeles Conservation Corps
Catherine Schneider	Jewish Federation of Greater Los Angeles
Matthew Sharp	California Food Policy Advocates
Dr. Paul Simon	Division of Chronic Disease and Injury Prevention, Los Angeles County Department of Public Health
Dr. Rachel Surls	University of California Cooperative Extension, Los Angeles County
Daniel Tellalian	Emerging Markets
Robert Tse	California Rural Development, U.S. Department of Agriculture
Alex Weiser	Weiser Family Farms
Goetz Wolff	Department of Urban Planning, UCLA Luskin School of Public Affairs
Larry Yee	Food Commons

Report Production

PRIMARY AUTHORS

Alexa Delwiche	Los Angeles Food Policy Council
Joann Lo	Food Chain Workers Alliance
Jill Overdorf	Coosemans Shipping
Vanessa Zajfen	San Diego Unified School District

RESEARCH SUPPORT

Amira Hasenbush
Anisha Hingorani
Katie Hoerberling
Colleen McKinney
Kimberly Tomicich

EDITORIAL REVIEW

Paula Daniels	Los Angeles Food Policy Council and Office of Mayor Villaraigosa, City of Los Angeles
----------------------	---

GRAPHIC DESIGN

Juliette Bellocq
and Yuju Yeo handbuiltstudio.com

© 2012 Los Angeles Food Policy Council

Acknowledgements

The Good Food Purchasing Guidelines for Food Service Institutions was made possible by the generous contributions, guidance, and expertise of many individuals.

CONTRIBUTORS

The Los Angeles Food Policy Council would especially like to thank the following individuals for providing sustained guidance and direction during the development of our guidelines.

Andrea Azuma	Community Benefit, Kaiser Permanente Southern California
David Binkle	Food Services Division, Los Angeles Unified School District
Devorah Brous	Netiya
Karl Bruskotter	Office of Sustainability and the Environment, City of Santa Monica
Elizabeth Epstein	
Renee Guilbault	Pret A Manger
Dana Gunders	Natural Resources Defense Council
Jacqueline Hernandez	American Heart Association
Cheryl Leahy	Compassion Over Killing
Sean Leer	Gold Star Foods
Josephine Miller	Office of Sustainability and the Environment, City of Santa Monica
Fritz Stelter	Field Fresh Foods
Michelle Wood	Los Angeles County Department of Public Health*

REVIEWERS

The Los Angeles Food Policy Council was fortunate to receive invaluable input on our guidelines from the following individuals:

Alexandra Agajanian	Sustainable Economic Enterprises Los Angeles
Martin Anenberg	FreshPoint Southern California
Eric Batch	American Heart Association
Jaya Bhumitra	Compassion Over Killing
Sandy Brown	Swanton Berry Farm & Geography Department, UC Berkeley
Danny Calvillo	Sunrise Produce
Sharon Cech	Urban & Environmental Policy Institute, Occidental College

Jim Cochran	Swanton Berry Farm & Food Commons
Cindy Crawford	Kaiser Permanente Southern California
George Faraday	Change to Win
Clare Fox	Los Angeles Food Policy Council
Steve Goodman	West Central Produce
Robert Gottlieb	Urban & Environmental Policy Institute, Occidental College
Kari Hamerschlag	Environmental Working Group
Glenda Humiston	California Rural Development, U.S. Department of Agriculture
Jonathan Kaplan	Natural Resources Defense Council
A.G. Kawamura	Orange County Produce
Kendra Klein	Physicians for Social Responsibility/ Health Care Without Harm
Bob Knight	Old Grove Orange, Inc
Michael Leighs	Los Angeles County Department of Public Health*
Toni Liquori	School Food Focus
Dan Madsen	Gold Star Foods
Erik Nicholson	United Farm Workers
Athena Pappas	California Produce Wholesaler
Kathleen Reed	Kaiser Permanente
Lucia Sayre	Physicians for Social Responsibility Health Care Without Harm
Dipa Shah	Los Angeles County Department of Public Health*
Matt Sharp	California Food Policy Advocates
Andy Shrader	Office of Councilmember Paul Koretz, Los Angeles City Council
Dr. Paul Simon	Los Angeles County Department of Public Health*
Dr. Rachel Surls	University of California Cooperative Extension, Los Angeles County
Daniel Tellalian	Emerging Markets
Marc Ross	
Mark Vallianatos	Urban & Environmental Policy Institute, Occidental College
Jesse Warnken	LA Specialties
Yelena Zeltzer	Urban & Environmental Policy Institute, Occidental College

* REVIEWER ONLY PROVIDED FEEDBACK ON NUTRITION GUIDELINES.



Photo credit: Haan-Fawn Chau

Table of Contents

- Good Food Purchasing Guidelines for Food Service Institutions / PAGE 09**
 - What Is Good Food Procurement? / PAGE 10
 - The Importance of Good Food Procurement / PAGE 10
 - Implementing a Good Food Program / PAGE 11
 - Budgeting for Good Food / PAGE 12
 - Methodology for Assessing Good Food Procurement / PAGE 12
 - Good Food Purchasing Program Goals / PAGE 12
 - Scoring System Examples / PAGE 13

- Value 1: Local Economies Purchasing Goals / PAGE 16**

- Value 2: Environmental Sustainability Purchasing Goals / PAGE 18**

- Value 3: Valued Workforce Purchasing Goals / PAGE 22**

- Value 4: Animal Welfare Purchasing Goals / PAGE 24**

- Value 5: Nutrition Goals / PAGE 26**

- APPENDIX A: Glossary of Terms / PAGE 31**

- APPENDIX B: Good Food Purchasing Resource Guide / PAGE 37**

- APPENDIX C: LOCAL PRODUCT AVAILABILITY (LOS ANGELES) / PAGE 41**



Photo credit: Haan-Fawn Chau

Good Food Purchasing Guidelines for Food Service Institutions

Food system transformation depends on large-scale shifts in the demand for and the subsequent purchasing of Good Food. By practicing Good Food purchasing methods, institutions can support food systems that are healthy, ecologically sound, economically viable, socially responsible, and humane. Universities and schools, hospitals, local governments, restaurants, and other institutions with food service venues are beginning to explore the opportunities afforded by thoughtful and value-based purchasing. By exercising their buying power, the purchasing practices of food service institutions can make a major difference in heightening the demand for and availability of Good Food.



The *Good Food Purchasing Guidelines for Food Service Institutions* is designed for public and private food enterprises in Los Angeles County and beyond to assist with their development of Good Food purchasing strategies. The guidelines include suggested measures and practical steps to implementing Good Food measures. The guidelines emphasize the following values:

- **Local Economies:** Support small and mid-sized agricultural and food processing operations within the local area or region.
- **Environmental Sustainability:** Source from producers that employ sustainable production systems that reduce or eliminate synthetic pesticides and fertilizers; avoid the use of hormones, antibiotics, and genetic engineering; conserve soil and water; protect and enhance wildlife habitat and biodiversity; and reduce on-farm energy consumption and greenhouse gas emissions.
- **Valued Workforce:** Provide safe and healthy working conditions and fair compensation for all food chain workers and producers from production to consumption.
- **Animal Welfare:** Provide healthy and humane care for livestock.
- **Nutrition:** Promote health and well-being by offering generous portions of vegetables, fruit, and whole grains; reducing salt, added sugars, fats, and oils; and eliminating artificial additives.

GOOD FOOD IS DEFINED BY THE LOS ANGELES FOOD POLICY COUNCIL AS FOOD THAT IS:

HEALTHY

Foods meet the Dietary Guidelines for Americans and provide freedom from chronic ailment.
Food is delicious and safe.

SUSTAINABLE

Food is produced, processed, distributed, and recycled locally using the principles of environmental stewardship (in terms of water, soil, and pesticide management).
accessible to all.

FAIR

All participants in the food supply chain receive fair compensation and fair treatment, free of exploitation.
High quality food is equitable and physically and culturally accessible to all.

AFFORDABLE

Foods that people of all income levels can purchase.

By suggesting opportunities to assess existing policies and methodologies within each establishment, this guide is intended to provide tools to help create a shift to a more diversified and resilient food system, with sustainable and ethical sourcing of food in all levels of food service operations. Good Food production, purchasing, and consumption will require coordinated multi-sector adoption and engagement with participants who are willing to adhere to an established minimum of Good Food procurement, outlined in this document. Included in this document is a tiered assessment of values to help procurement and purchasing offices determine the current state of their farmers and other vendors. This guide is a first step in creating a comprehensive Good Food program that will inform, encourage, support and promote food service establishments of all sizes to become Good Food leaders in their communities.

WHAT IS GOOD FOOD PROCUREMENT?

The term procurement refers to the sourcing and purchasing of food to supply food service operations. This process is much more complex than it may appear on the surface or to one unfamiliar with commercial food service operations. Procurement involves identifying the food needs of the customer base for the food service operation, specifying product requirements, identifying suppliers, taking deliveries, inspecting and storing items, and, depending on the size of the operation, soliciting and evaluating bids and proposals, controlling inventory, and paying suppliers. These guidelines are designed to assist an individual tasked with implementing a Good Food program in their food service operation.

THE IMPORTANCE OF GOOD FOOD PROCUREMENT

Institutions of all kinds, from K-12 schools, universities, and hospitals, to corporate cafeterias and local government agencies, are major purchasers and servers of food. They are therefore in a unique position to influence food supply chains. Due to the collective large purchasing volume, institutional demand for Good Food can encourage suppliers to shift their production practices in order to supply environmentally sustainable, socially responsible, and healthy food products.

Good Food sourcing benefits may include:

- **Economic:** Support of local and regional farmers and food businesses, returning to the local economy three times the purchase price of a food product purchased from out of state;
- **Environmental:** Reduction of food miles, greenhouse gases, carbon footprints, and pollution; promotion of soil fertility, human and animal health, and the conservation of water and biodiversity;
- **Nutritional:** Encouragement of increased purchasing of whole foods and local produce that is fresher and has a higher nutritional content, due to the shorter period of time between harvest and sale;
- **Social:** Transformation of the supply chain, rewarding farmers and food businesses for environmentally sustainable and socially responsible business practices.

Large-scale demand for Good Food is fundamental to building the market for Good Food. By increasing the demand, and thus the infrastructure to distribute Good Food, it will become easier for more institutions to participate. Strong and steady demand for Good Food will increase its affordability and availability in all communities.

Hospitals, universities, schools, and restaurants in Los Angeles have spearheaded the adoption of local and sustainable food procurement policies and these innovators should be looked to as local leaders in proving that, by changing the way one purchases, institutions can create opportunities for regional farmers to thrive, for workers to receive just compensation and fair treatment, for local economies to continue to rebuild, and for reducing our environmental footprint. These outcomes can be accomplished while also increasing access to and consumption of fresh and nutritious food, particularly in underserved communities. The goal of a Good Food procurement system is to bring multiple benefits to all communities by impacting health, social well-being, bottom-line business success, and the environment.

Public institutions, in particular, play a critical role in increasing access to Good Food.

Through their reach to some of the most vulnerable populations, including seniors and children, public programs help ensure that all Angelenos have access to the healthiest foods. These agencies purchase food to provide meals to people in public hospitals, child-care centers, schools, senior programs, jails, and juvenile facilities. Such programs and institutions provide a buffer against hunger, food insecurity

and also serve as a primary source of nutrition for millions of residents. Public and private institutions also purchase food to sell to employees and the public in retail outlets such as vending machines, cafeterias, and concession stands.

Various Los Angeles wholesale food companies have implemented local food lines and certify that their products fall within a variety of parameters. This practice has expanded into processing lines and local fruits and vegetables can now be purchased to create a line of value-added products that are verified as locally sourced (i.e. carrot sticks, bagged salads, crudités, etc.).

Los Angeles nutrition education programs such as the California Department of Public Health and Network for a Healthy California's *Harvest of the Month* program, administered by LAUSD in 250 Los Angeles schools, and some of the Los Angeles county WIC-Only stores are using guidelines that state that their Good Food is sourced from:

- Farms within 200 miles of the final service of the product
- Farms that are less than 200 acres
- Farms that provide more than five items annually (this excludes mono-cropping and allows for crop diversity and better soil management)

Over time, Good Food purchases, from both large and small institutions, can add up to significant investments in a sustainable regional food system.

IMPLEMENTING A GOOD FOOD PROGRAM

Before implementing changes, operations should assess:

- What are the advantages to your institution and the community for purchasing Good Food?
- What percentage of currently purchased food is already local, sustainable, and fairly produced?
- What barriers will limit participation in the program?
- Are there extra transportation costs affiliated with purchasing an increased volume in local products?
- What are the additional processing costs affiliated with purchasing local? What methods exist for offsetting such costs?
- What types of local, sustainable, and fairly produced products do existing distributors or vendors offer?
- How will your institution communicate the changes to consumers and employees?

Prior to implementation, it is also critical to develop operational definitions for words that will be used in Good Food bids; words like: sustainable, fair, local, or humane need to have clear criteria and a means for measurement and compliance (see Appendix A for our glossary of terms). Compliance and/or meeting Good Food objectives will more often than not fall to producers, food distributors, and processors. Without a direct relationship to farmers, ensuring sustainability of foods and beverages requires access to information about the value chain and the farms that produced such foods. Outside of a personal relationship with producers, third-party labels (CCOF, AGA Grassfed, etc.) are useful tools for ensuring sustainability if they are grounded in verifiability.

Most distributors are willing to take on the task of providing origins of their product, particularly if there is a long-term sales opportunity. Often the simple act of asking distributors how they will meet Good Food requirements indicates to suppliers that sustainability and health are important for an institution. Distributors will work with the buyer to develop a qualified Good Food program with buyer-specified parameters.

BUDGETING FOR GOOD FOOD

Sustainable foods are generally associated with higher prices than conventional foods, thus creating little incentive for increasing purchases. However, there are a variety of strategies food service venues can employ to offset increased costs associated with purchasing higher quality foods. In 2012, Los Angeles Unified School District was able to improve meal quality, increase the percent of produce purchased and source approximately 70 percent of that produce locally (within 200 miles), while their food budget remained constant, despite rising food prices nationally. A recent study prepared for UCLA Housing & Hospitality Services found that four UC campuses with sustainable food policies – Davis, Berkeley, San Diego, and Santa Cruz – showed little, if any, increase in per plate costs after sustainable spending. Retailers have found as they increase Good Food purchases, suppliers increase production and, subsequently, food prices fall.

Strategies for offsetting increased costs include:

- Re-designing menus to incorporate less meat and processed food;
- Buying produce in season;
- Creating direct relationships with suppliers;
- Partnering with other food purchasing departments or institutions to leverage purchasing volume;
- Increasing sustainable food purchases incrementally;
- Purchasing foods from produce aggregation hubs (Regional Food Hubs);
- Increasing water and energy efficiency (e.g. by eliminating trays); and
- Buying lower on the beauty chain (e.g., smaller and less aesthetically perfect produce) is less expensive and helps farmers sell more of what they grow.

The guidelines suggested in this document were identified with full acknowledgement of the very real constraints and tight budgets institutions face when trying to provide their customers the highest quality food. To establish varying degrees of Good Food compliance, these guidelines outline tiers of adoption for food service outlets based on procurement standards. Purchasers will need to identify their initial purchasing priorities and incorporate additional standards and levels of adoption in the next stages of the development of their program.

METHODOLOGY FOR ASSESSING GOOD FOOD PROCUREMENT

A tiered value system has been developed to evaluate the potential contribution of purchases to a Good Food Purchasing Program. A baseline in each category is established that must be maintained throughout participation in the program with qualifications noted at both the one year and five year goal levels. By creating goals for a first year of completion through a five-year implementation plan, a great opportunity is created for thoughtful, strategic and progressive sourcing and menu development.

The tiered value system allows for purchasers to participate at varying levels and to scale up their Good Food purchasing over time. Within each value category, purchasers may choose to participate at Levels One, Two or Three. Level One criteria within each value category are assigned one point. Level Two criteria for each value category are more rigorous than Level One and are assigned two points. Level Three criteria within each value category are the premier levels of achievement in the program and are assigned three points.

Purchasers that meet the baseline level for each category are awarded with Good Food Purchaser recognition. A purchaser must score a minimum of five points to meet baseline requirements as a participant in the Good Food Purchasing Program and receive one star. Purchasers scoring 10-14 points receive two stars, purchasers scoring 15-19 points receive three stars, purchasers scoring 20-24 points receive four stars, and purchasers scoring 25 points or more receive five stars. Good Food Purchasers with five stars represent the most dedicated supporters of the Good Food Purchasing Guidelines. These Good Food Purchasing Guidelines are easily modified for any national food service company or government agency.

GOOD FOOD PURCHASING PROGRAM GOALS

The following Good Food goals have been adapted from a variety of local and sustainable food purchasing policies including the City of New York, Kaiser Permanente, Emory University, Yale University, and University of California and are a suggested benchmark for purchasers developing or implementing a Good Food purchasing program. Food service facilities can adjust percentages as necessary with the goal of gradually increasing their Good Food purchases.

GOOD FOOD PURCHASING COMMITMENT LEVELS

 Good Food Purchaser	 Good Food Purchaser	 Good Food Purchaser	 Good Food Purchaser	 Good Food Purchaser
5–9 Points Needed	10–14 Points Needed	15–19 Points Needed	20–24 Points Needed	25+ Points Needed

BASELINE REQUIREMENT

All Good Food Purchasers must score at least one point in each value category.

MIXING LEVELS AND VALUES

Points may be earned by mixing various commitment levels and value categories.

—Example

2 points from Level 2 of Nutrition + 1 point from Level 1 of Animal Welfare = 3 points total

ACCUMULATION OF POINTS

Cumulative points may be earned if purchasers comply simultaneously with different commitment levels within a particular value category.

—Example

From the Environmental Sustainability category, participants can earn 6 points by fulfilling all the different requirements for Levels 1, 2 and 3.

EXPECTATIONS FOR INCREASED COMMITMENT

After one year of participation in the program, purchasers will be expected to gradually increase the amount of Good Food that they purchase in order to maintain the same number of points. See Good Food Purchasing Guidelines for more details.

SCORING SYSTEM EXAMPLES

These two hypothetical examples will help Good Food Purchasers understand how the Good Food Purchasing Pledge scoring system works. In both of the following examples, the institutions earn three-star ratings (requiring 15-19 points), but each organization takes a different approach.

LEVELS \ VALUE	1	2	3	4	5
EXTRA POINTS	2				1
LEVEL 3			3		3
LEVEL 2	2		2		
LEVEL 1		1		1	

TOTAL 15 POINTS =  Good Food Purchaser

LEVELS \ VALUE	1	2	3	4	5
EXTRA POINTS	1	2	1		
LEVEL 3	3	3			
LEVEL 2		2		2	2
LEVEL 1	1		1		

TOTAL 18 POINTS =  Good Food Purchaser

Pomegranates
\$3.00 a pound

Pomegranates
Pomegranates have great sweet-tart flavor and have long been a favorite for special occasions. Their seeds, known as pomegranate seeds, are packed with antioxidants and are a good source of fiber. Pomegranates are also a good source of potassium and calcium. Pomegranates are a healthy addition to your diet.

ORGANIC
Delicious
Apples
\$3.00 a pound
2 lbs / \$5.00



An Overview of Good Food Values

Procurement suggestions will focus on sourcing products that align with these Good Food principles:

LOCAL ECONOMIES (LOCAL FOOD)

- Use local, seasonally available ingredients from community supported, small and medium sized farms and food processing facilities, to maintain local economies, create jobs, prevent sprawl, preserve farmlands, provide fresher food, and minimize transport and storage. If local ingredients are not available, use regional or at a minimum, domestic, ingredients.

ENVIRONMENTAL SUSTAINABILITY (ENVIRONMENTALLY SUSTAINABLE FOOD)

- Specify food from farming systems that minimize harm to the environment; such as certified organic farms, farms offering high bio-diversity of crop yield, farms actively reducing risk created through pesticide use, and soil enrichment and water conservation programs.
- Avoid food products with supplemental growth hormones and non-therapeutic antibiotics and Genetic Modification (GMO) of crops, livestock, and livestock feed.
- Minimize foods of animal origin (meat, dairy products, and eggs), as livestock farming is one of the most significant contributors to climate change.
- Exclude fish species identified as most 'at risk' by the Marine Conservation Society and Monterey Bay Aquarium's Seafood Watch and give preference to fish derived from sustainable sources.
- Purchase lower-grade (less than retail quality) produce for use in prepared dishes to allow more complete use of farm produce, to reduce waste, and to reduce costs.
- Minimize bottled water sales and instead serve plain or filtered tap water in reusable jugs or bottles, to minimize transport and packaging waste.

VALUED WORKFORCE (FAIR FOOD)

- Choose food products that ensure safe and healthy working conditions, fair compensation, and a voice at work for all food chain workers and producers from production to consumption.
- Choose food and drink products that ensure a fair deal for producers and workers in developing nations and economies.

ANIMAL WELFARE (HUMANE FOOD)

- If animal products are a featured menu item, ensure that meat, dairy products, and eggs are produced using high verifiable animal welfare standards which consumers would consider to be significantly higher than standard industry practices.

NUTRITION (HEALTHY FOOD)

- Promote health and well-being by offering generous portions of vegetables, fruit, and whole grains while reducing salt, added sugars, fats, oils, and red meat consumption, and eliminating artificial additives.

Improving equity, affordability, accessibility, and consumption of high quality culturally relevant Good Food in all communities is central to our focus on advancing Good Food purchasing practices.

Value 1: Local Economies Purchasing Goals

LEVEL 1 — BASELINE	LEVEL 2	LEVEL 3
<p>Local within 200 miles¹ (or 10 Southern California counties) AND large scale operations² (>500 acre farms);</p> <p>or</p> <p>Outside of the local 200 mile range but within California AND medium scale operations (180-499 acre farms);</p> <p>or</p> <p>Outside of California AND small scale operations (<180 acre farms)</p>	<p>Local within 200 miles (or 10 Southern California counties) AND medium scale operations;</p> <p>or</p> <p>Outside of the local 200 mile range but within California AND small scale operations</p>	<p>Local within 200 miles (or 10 Southern California counties) AND small scale operations</p>

To be recognized as a Good Food purchaser, an institution scores one or higher in the Local Economies Category.

TARGET	POINTS AWARDED
<p>LEVEL 1 — BASELINE</p> <p>Year 1: 15% annual average of total cost of food purchases, with a goal of increasing at least 2% per year will come from Level 1 local food sources (See glossary for definition of source).</p> <p>OR</p> <p>If vendor and/or suppliers do not have current capacity to meet local food purchasing goals, the vendor may submit a plan to achieve full compliance at least at the baseline level by end of year one.</p>	1
<p>Year 5: 25% annual average of total cost of food purchases will come from Level 1 local food sources by fifth year of participation.</p>	1
<p>LEVEL 2</p> <p>Year 1: 15% annual average of total cost of food purchases, with a goal of increasing at least 2% per year will come from Level 2 local food sources.</p>	2
<p>Year 5: 25% annual average of total cost of food purchases will come from Level 2 local food sources by fifth year of participation.</p>	1
<p>LEVEL 3</p> <p>Year 1: 15% annual average of total cost of food purchases, with a goal of increasing at least 2% per year will come from Level 3 local food sources.</p>	3
<p>Year 5: 25% annual average of total cost of food purchases will come from Level 3 local food sources by fifth year of participation.</p>	1
<p>EXTRA POINTS</p> <p>Food is purchased from microenterprise farm of less than 100 acres and located within 200 miles.</p>	1
<p>(Applies to annual food purchases)</p> <p>Food is grown/raised and processed in Los Angeles County.</p>	1
<p>Food is purchased directly from farmer-owned businesses.</p>	1
<p>Food is purchased from women, minority, disabled, or veteran-owned food businesses (farms/operations).</p>	1
<p>50% of total cost of food purchases comes from small and mid-sized food operations within the local area or region.</p>	1
<p>At least 25% of prepared seafood sourced from small and or local fleets.</p>	1

Steps to Implementation:

- Source local agricultural and food products directly from farmers and ranchers at certified farmers' markets in City of Los Angeles and/or Los Angeles County (See Appendix B: Good Food Purchasing Resource Guide – Learn More About Good Food Sourcing: Local Food).
- Buy local agricultural and food products from distribution firms that verifiably buy from farmers' market certified producers at Los Angeles County certified farmers' markets.
- Buy local agricultural and food products from distribution firms that buy from other verified local farms and producers.
- Buy local agricultural and food products from distribution firms and processors that have a verifiable local food line (See Appendix C for listings).
- Work with distributors to source seasonal fruits and vegetables to ensure best taste, quality, and price.

¹The Los Angeles Food Policy Council defines local as 200 miles, ten counties and touching over 22 million people. This ten county region includes: Kern, Ventura, San Diego, Imperial, Riverside, Santa Barbara, San Luis Obispo, San Bernardino, Orange and Los Angeles.

²To measure the size of other agricultural and food processing operations, see the glossary for full details.

Value 2: Environmental Sustainability Purchasing Goals

FRUITS & VEGETABLES



LEVEL 1 — BASELINE

Farms agree to participate in Stewardship Index for Specialty Crops;  or
PRiME score has no high risk components for Integrated Pest Management Practices

LEVEL 2

PRiME score indicates low-risk for Integrated Pest Management Practices; or
Protected Harvest certified;  or
Farms participate in Stewardship Index for Specialty Crops with targets for annual improvement;  or
Non-GMO Project Verified;  or
Food Alliance Certified 

LEVEL 3



USDA Organic;  or
Biodynamic 

MILK & DAIRY

LEVEL 1 — BASELINE

No antibiotics; and
rBGH/rBST free

LEVEL 2

Non-GMO Project Verified;  or
Animal Welfare Approved 

LEVEL 3

Food Alliance Certified;  or
USDA Organic 

MEAT & POULTRY

LEVEL 1 — BASELINE

Cage-free eggs; or
Pasture raised; or
USDA Grassfed; or
No antibiotics³

LEVEL 2

AGA Grassfed;  or
Non-GMO Project Verified;  or
Animal Welfare Approved 

LEVEL 3

Food Alliance Certified;  or
USDA Organic 

SEAFOOD

LEVEL 1 — BASELINE

No seafood purchased listed as “Avoid” in the Monterey Bay Aquarium’s Seafood Watch Guide



LEVEL 2

Fish listed as “Good” and “Best” choices in Monterey Bay Aquarium’s Seafood Watch Guide



LEVEL 3

Marine Stewardship Council certified;
or
100% of fish listed as “Best Choice” in Monterey Bay Aquarium’s Seafood Watch Guide



GRAINS

LEVEL 1 — BASELINE

Pesticide-free

LEVEL 2

Food Alliance Certified;
or
Non-GMO Project Verified



LEVEL 3

USDA Organic



³ “No antibiotics” refers to sub-therapeutic use in food production. It does not refer to residues on the meat itself.

To be recognized as a Good Food purchaser, an institution scores one or higher in the Environmental Sustainability Category.

	TARGET	POINTS AWARDED
LEVEL 1 — BASELINE	YEAR 1 1) 15% annual average of total cost of food purchases, with a goal of increasing at least 2% per year will come from Level 1 environmentally sustainable sources. 2) No seafood purchased should be listed as “Avoid” in the Monterey Bay Aquarium’s most recent Seafood Watch Guide. OR If vendor and/or suppliers do not have current capacity to meet environmentally sustainable food purchasing goals, the vendor may submit a plan to achieve full compliance at least at the baseline level by end of year one.	1
	YEAR 5 1) 25% annual average of total cost of food purchases will come from Level 1 environmentally sustainable sources by fifth year of participation in the GFPP program. 2) No seafood purchased should be listed as “Avoid” in the Monterey Bay Aquarium’s most recent Seafood Watch Guide.	1
LEVEL 2	YEAR 1 1) 15% annual average of total cost of food purchases, with a goal of increasing at least 2% per year will come from Level 2 environmentally sustainable sources. 2) No seafood purchased should be listed as “Avoid” in the Monterey Bay Aquarium’s most recent Seafood Watch Guide.	2
	YEAR 5 1) 25% annual average of total cost of food purchases will come from Level 2 environmentally sustainable sources by fifth year of participation. 2) No seafood purchased should be listed as “Avoid” in the Monterey Bay Aquarium’s most recent Seafood Watch Guide.	1
LEVEL 3	YEAR 1 1) 15% annual average of total cost of food purchases, with a goal of increasing at least 2% per year will come from Level 3 environmentally sustainable sources. 2) No seafood purchased should be listed as “Avoid” in the Monterey Bay Aquarium’s most recent Seafood Watch Guide.	3
	YEAR 5 1) 25% annual average of total cost of food purchases will come from Level 3 environmentally sustainable sources by fifth year of participation. 2) No seafood purchased should be listed as “Avoid” in the Monterey Bay Aquarium’s most recent Seafood Watch Guide.	1
EXTRA POINTS (Applies to annual food purchases)	Institution participates in “Meatless Mondays” campaign.	1
	A minimum of 75% percent of all seafood is noted as “Best Choices” in the Monterey Bay Aquarium Guide or is certified by the Marine Stewardship Council.	1
	50% annual average of total cost of food purchases comes from environmentally sustainable sources.	1



Steps to Implementation:

- Request that your distributor buy food and beverage products that are third-party certified (See Appendix B: Good Food Purchasing Resource Guide – Learn More About Good Food Sourcing: Environmentally Sustainable Food).
- Ask your distributor to encourage suppliers to participate in the Stewardship Index for Specialty Crops to begin measuring their baseline sustainability indicators and develop targets for continued progress (See Appendix B: Good Food Purchasing Resource Guide – Learn More About Good Food Sourcing: Environmentally Sustainable Food).
- Request that your distributors buy and sell seafood that is listed in the Monterey Bay Aquarium’s Seafood Watch Guide as “Best Choices” or is certified by the Marine Stewardship Council (See Appendix B: Good Food Purchasing Resource Guide – Learn More About Good Food Sourcing: Sustainable Seafood).

Value 3: Valued Workforce Purchasing Goals

LEVEL 1 — BASELINE





- Distributor has policy to respect the freedom of association of farmers, ranchers, and fisherfolk; and
- All vendors and suppliers*: sign in writing that they comply with domestic labor law (including state and local) in countries where they produce goods and services, as well as the core standards of the International Labour Organization (ILO): 

1. Freedom of association and the right to collective bargaining.
2. Elimination of all forms of forced or compulsory labor.
3. Abolition of child labor.
4. Elimination of discrimination with respect to employment or occupation

LEVEL 2

- Meets the Level 1 baseline requirements; and Vendor and Supplier*
- Have a social responsibility policy, which includes:
 - (1) union or non-poverty wages;
 - (2) respect for freedom of association and collective bargaining;
 - (3) safe and healthy working conditions; and
 - (4) prohibition of child labor, except as allowed by domestic law and at least one additional employment benefit such as:
 - (5) health care benefits
 - (6) paid sick days;
 - (7) profit-sharing with all employees;
- Are Fair Trade Certified  (for international products)

LEVEL 3

- Meets the Level 1 baseline requirements; and Vendor and Supplier*
- Have a union contract with their employees; or
- Are a worker-owned Cooperative;  or
- Have signed the CIW Fair Food Supplier Code of Conduct;  or
- Are Food Justice-Certified by the Agricultural Justice Project;  or
- Are certified by the Equitable Food Initiative 

* Scope of vendors and suppliers:

- Fresh Produce: Farm AND distributor (if not purchasing directly from the farm)
- Minimally processed fresh produce: Production source (e.g. farm, fishery, ranch) AND processing facility AND distributor (these may all be separate entities or may be combined, depending upon the product)
- Animal Products: Production source (e.g. farm, fishery, ranch) AND slaughtering/processing facility AND distributor (these may all be separate entities or may be combined, depending upon the product)
- Processed Foods: Processing/Manufacturing Plant AND distributor (if not purchasing directly from the processing/manufacturing plant)



Photo credit: Scott Robertson

To be recognized as a Good Food purchaser, an institution scores one or higher in the Valued Workforce Category.

	TARGET	POINTS AWARDED
LEVEL 1 — BASELINE	Year 1: All vendors and suppliers sign in writing that they respect the freedom of association of farmers, ranchers, and fisherfolk and comply with domestic labor law (including state and local) in countries where they produce goods and services, as well as the core ILO standards. OR If vendor and/or suppliers do not have current capacity to meet fair food purchasing goals, the vendor may submit a plan to achieve full compliance at least at the baseline level by end of Year 1.	1
	Year 5: All vendors and suppliers sign in writing that they respect the freedom of association of farmers, ranchers, and fisherfolk and comply with domestic labor law (including state and local) in countries where they produce goods and services, as well as the core ILO standards.	1
LEVEL 2	Year 1: Institution complies with baseline Level 1 fair criteria AND 5% annual average of total cost of food purchases, with a goal of increasing at least 2% per year will come from Level 2 fair sources.	2
	Year 5: Institution complies with baseline Level 1 fair criteria AND 15% annual average of total cost of food purchases will come from Level 2 fair sources by fifth year of participation.	1
LEVEL 3	Year 1: Institution complies with baseline Level 1 fair criteria AND 5% annual average of total cost of food purchases, with a goal of increasing at least 2% per year will come from Level 3 fair sources.	3
	Year 5: Institution complies with baseline Level 1 fair criteria AND 15% annual average of total cost of food purchases will come from Level 3 fair sources by fifth year of participation.	1
EXTRA POINTS (Applies to annual food purchases)	Buying entity establishes a reporting system for workers to report violations with a protection for workers from retaliation.	1
	Institution complies with baseline Level 1 fair criteria AND 25% of annual average of total cost of food purchases comes from Level 2 or 3 fair sources.	1

Steps to Implementation:

- Ask that your distributor source agricultural products, which come from farms and food processors with union contracts or certified by one of the programs in the Level 3 Valued Workforce category (See Appendix B: Good Food Purchasing Resource Guide – Learn More About Good Food Sourcing: Valued Workforce).
- Ask your distributor to encourage suppliers to review the Agricultural Justice Project’s toolkit and a list of resources to help farmers and food businesses to adjust their labor policies, develop documentation, and learn how to develop a social responsibility policy.⁴

- Ask your distributor to develop long-term relationships with its suppliers and pay fair prices – review the Agricultural Justice Project’s standards section on Food Business Responsibilities to Farmers.⁵

⁴http://www.agriculturaljusticeproject.org/full_farmer_toolkit.pdf

⁵http://www.agriculturaljusticeproject.org/AJP_stnds_sect_1.pdf

Value 4: Animal Welfare Purchasing Goals

MILK & DAIRY



LEVEL 1 — BASELINE

Produced from Pastured Cows;
or
USDA Organic 

LEVEL 2

American Humane Certified 

LEVEL 3

Animal Welfare Approved; 
or
Humane Farm Animal Care/Certified 
Humane Raised and Handled®

MEAT & POULTRY

LEVEL 1 — BASELINE

Step 1 of Global Animal Partnership
5-Step Animal Welfare Rating
standards; 
or
USDA Organic; 
or
Cage-free eggs;
or
Pastured

LEVEL 2

Step 2 of Global Animal Partnership
5-Step Animal Welfare Rating
standards; 
or
American Humane Certified 

LEVEL 3

Step 3 or higher of
Global Animal Partnership
5-Step Animal Welfare Rating
standards; 
or
Animal Welfare Approved; 
or
Humane Farm Animal Care/Certified
Humane Raised and Handled®



Photo credit: Haani-Fayy Chau

	YEAR 1 TARGET	POINTS AWARDED
LEVEL 1 — BASELINE	Year 1: 1) 15% annual average of total cost of milk and dairy products and animal protein product purchases, increasing at least 2% per year will come from Level 1 humane sources. 2) 100% of all eggs are cage-free. OR If vendor and/or suppliers do not have current capacity to meet animal welfare purchasing goals, the vendor may submit a plan to achieve full compliance at least at baseline level by end of year one.	1
	Year 5: 1) 25% annual average of total cost of milk and dairy products, and animal protein product purchases will come from Level 1 humane sources by fifth year of participation. 2) 100% of all eggs are cage-free.	1
LEVEL 2	Year 1: 1) 15% annual average of total cost of milk and dairy products and animal protein products, increasing at least 2% per year will come from Level 2 humane sources. 2) 100% of all eggs are cage-free.	2
	Year 5: 1) 25% annual average of total cost of milk and dairy products, and animal protein product purchases will come from Level 2 humane sources by fifth year of participation. 2) 100% of all eggs are cage-free.	1
LEVEL 3	Year 1: 1) 15% annual average of total cost of milk and dairy products, and animal protein product purchases, increasing at least 2% per year will come from Level 3 humane sources. 2) 100% of all eggs are cage-free.	3
	Year 5: 1) 25% annual average of total cost of milk and dairy products, and animal protein product purchases will come from Level 3 humane sources by fifth year of participation. 2) 100% of all eggs are cage-free.	1
EXTRA POINTS (Applies to annual food purchases)	Institution encourages plant based diets by offering 100% vegetarian and/or vegan options.	1
	50% annual average of total cost of milk and dairy products, and animal protein products purchases come from humane sources.	1

Steps to Implementation:

- Request that your distributor buy and sell animal protein products that carry a third-party certification such as, Global Animal Partnership, produced from AGA Grass-Fed cows, Humane Farm Animal Care/Certified Humane Raised and Handled®, and Animal Welfare Approved (See Appendix B: Good Food Purchasing Resource Guide – Learn More About Good Food Sourcing: Animal Welfare).

⁶ If only plant-based food options are offered and thus no milk and dairy products, eggs, and animal protein products are purchased, institution receives full (3) points.

Value 5: Nutrition Goals

To be recognized as a Good Food purchaser, an institution meets at least 13 out of 25 items in the Nutrition Category⁷

YEAR 1 TARGET	POINTS AWARDED
Fruits, vegetables, and whole grains account for at least 25% of total food purchases	1
Seasonal fruits and vegetables are sourced to ensure best taste, quality, and price	1
To the greatest extent possible, purchase whole fruits, without added sugar. When whole and unprocessed fruit cannot be purchased, due to cost or availability, purchase frozen fruit. If frozen products are unavailable, fruit should be canned in its own juice with no sugars added	1
To the greatest extent possible, purchase whole vegetables, without added sodium and fat. When whole and unprocessed vegetables cannot be purchased due to cost or availability, purchase frozen vegetables. If frozen products are unavailable, canned vegetables should be low sodium (per FDA definitions) ⁸ or have “no salt added”	1
Prioritize the purchase of whole-grain, high-fiber options ⁹	1
Prioritize offering plant-based main dishes at each meal service ¹⁰	1
If meat is offered, prioritize the purchase of “extra lean” (total fat ≤ 5%) and “lean” (total fat ≤ 10%) meat such as skinless chicken, turkey, ground beef, and pork	1
If meat is offered, minimize the purchase of processed meats ¹¹	1
If dairy products are offered, prioritize the purchase of Fat-Free or Low Fat dairy products (1% milk fat or less with no added sweeteners). If milk is offered, soy, rice, or other non-dairy milk alternatives without added sweeteners are available	1
Prioritize all juice purchased to be 100% fruit juice with no added sweeteners and vegetable juice that is Low Sodium as per FDA definitions ¹²	1
At least 50% of available beverage choices (excluding 100% fruit and Low Sodium vegetable juices and Fat Free or Low Fat milk with no added sweeteners) must contain ≤ 25 calories per 8 ounces	1
Require drinking water (preferably cold tap water in at least 12 ounce cup sizes) to be offered	1
Eliminate the use of hydrogenated and partially hydrogenated oils for cooking and baking	1
Offer Low Fat and/or Low Calorie and/or Low Sodium condiments as per FDA definitions ¹³	1
Commit to developing and implementing a gradual sodium reduction plan that meets current Dietary Guidelines for Americans (DGA) standards	1
All pre-packaged food has zero grams trans fat per serving (as labeled)	1
Eliminate the use of deep frying	1
Prioritize the preparation of all protein, including fish, poultry, meat, or meat alternatives in a low fat way (broiling, grilling, baking, poaching, roasting, or steaming)	1
Display water, diet drinks (do not exceed 25 cal. per 8oz), 100% fruit juice without added sweeteners, Low Sodium vegetable juices, Fat Free or Low Fat dairy products with no added sweeteners, and milk alternative products in eye level sections of beverage cases (if applicable)	1
Prioritize the location of fruit and/or non-fried vegetables at convenient, high-visibility locations (including at front of cafeteria lines) and within reach of checkout registers (if applicable)	1

Highlight fruit with no-added sweeteners and non-fried vegetable offerings with signage	1
Remove candy bars, cookies, chips and beverages with added sugars (such as soda, sports and energy drinks) from checkout register areas/point-of-purchase (if applicable)	1
Menu lists the nutritional information for each item using the federal menu labeling requirements under the Patient Protection and Affordable Care Act of 2010 as a guide	1
Prioritize portion control strategies, if applicable (e.g. utilizing 10' or smaller plates for all meals or make available reduced-size portions of at least 25% of menu items offered, and offer reduced-size portions at a lower price than regular-sized portions) ¹⁴	1
Develop a worksite wellness program including nutrition education for employees and/or patrons	1

LEVEL 1 HEALTHY – MEETS 13–15 OUT OF 25

LEVEL 2 HEALTHY – MEETS 16–20 OUT OF 25

LEVEL 3 HEALTHY – MEETS 21–25 OUT OF 25

EXTRA POINTS HEALTHY – MEETS ALL 25 POINTS (1 POINT)

⁷All nutrition goals listed above may not apply to all types of food service institutions. Food service institutions must ensure the above nutrition goals comply with local, state and federal law that may govern individual food service programs such as youth detention facilities, school meal programs and other meals served to dependent community members. Each food service institution will be eligible for points towards the good food pledge based on the total potential applicable points for that type of food service venue. LAFPC will work with each institution individually on their institution's pledge criteria. These nutrition goals were developed from reputable sources including the United States Department of Agriculture, the Food and Drug Administration, as well as other leading health organizations. The above nutrition goals will be reviewed and revised periodically to ensure they meet current dietary recommendations and take into consideration program implementation.

⁸Low sodium is defined as 140 mg or less per Reference Amount Customarily Consumed (RACC)

⁹Whole grain is listed as the first or second ingredient; 2 grams or more of fiber/serving

¹⁰Recommend plant-based dishes to include fruits, vegetable, beans, and legumes

¹¹If processed meats are offered, recommend using only products with no more than 480 mg per 2 oz.

¹²Low Sodium is 140 mg or less per RACC

¹³Low-Fat is 3 g or less per RACC (and per 50g if RACC is small); Low Sodium is 140 mg or less per RACC (and per 50g if RACC is small); Low Calorie is 40 calories or less per RACC (and per 50g if RACC is small).

¹⁴Reduced-sized portions are no more than 70% of the weight, measured in grams, of a regular-size portion of the same menu item.

ACCOUNTABILITY AND TRACEABILITY

An institution's Good Food purchases are generally limited by their produce and distribution firms because of their access to products carrying food safety approval. Compliance and/or meeting procurement objectives also fall to the produce and food distributors. Therefore bids and contracts should have clauses for ascertaining product traceability, identification, record keeping, and reporting. These clauses may already be accommodated in current Hazard Analysis & Critical Control Points (HACCP) and other third-party action plans.

The Purchaser should develop a customized program in partnership with their distributor and/or produce house to accomplish all of the traceability necessary for each purchaser's specific needs around Good Food purchases.



Sound Good Food bids could include the following accountability and traceability requirements for any produce or distribution firm:

- The name and location of farms and processing facilities providing Good Food to an institution will be provided to the institution at the time of ordering, a week or two prior to ordering or on the product list of available food items. Typically, the produce lists of available products from distributors and produce houses are the way buyers are notified to select the food they want to purchase. Vendors should list how each Good Food supplier fulfills and verifies identified Good Food goals, including local, environmentally sustainable, fair, animal welfare and healthy.
- If an existing vendor is unable to comply with specific targets within the overall Good Food framework, the vendor will be asked to submit a plan outlining a strategy with benchmarks to achieve full compliance within one year and update the plan annually during term of contract. Vendors will verify their progress and compliance with the plan during specified benchmark periods.
- The vendor will provide the net price paid to farmers, ranchers, or fisherfolk to the Purchasing Institution on a per pound, per case, or other applicable case count prior to the distributor's or produce firm's mark up. Costs should be fair, reasonable and transparent. The Purchaser should develop this transparent program in partnership with their Distributor and/or Produce House.
- Paperwork that proves the origin of any processed food items will be provided to an institution upon request, but shall be kept on record by produce or distribution firms. We recommend the development and implementation of a transparent record keeping system between purchasers and fresh produce processors so that there are checks and balances in place in order to confirm that Good Food products remain intact throughout the processing chain

EDUCATION AND MARKETING

Marketing and education of Good Food are critical to building buy-in and support from employees, consumers, and other customers.

Educate and engage – Suppliers and their employees along the supply chain from farm to cafeteria need to be informed, educated, and encouraged to be active participants in creating a successful Good Food Purchasing Program. Successful implementation of these programs in food service settings depends on empowered food service workers in the kitchens and knowledgeable employees, students, or customers visiting the food service venue.

Communicate good work, helping to encourage growth in both the demand for and the supply of Good Food. Be a willing educator of patrons and colleagues.

FINAL THOUGHTS

Food is only one facet of creating a Good Food community. Advocacy for Good Food venues involve several other components:

- Educational outreach both to staff and the surrounding community;
- Use of reusable and environmentally preferred non-reusable food service ware items and minimizing waste by adopting the waste hierarchy of reduce, reuse, and recycle ;
- Reducing energy use by installing energy-efficient equipment and making sure it is properly maintained and up-to-date;
- Supporting local farms, farmers' markets, and community supported agriculture;
- Food donation and waste reduction;
- Alignment of food vendor options with the facility's healthy, sustainable food program; and
- Responsible employer policies related to wages, benefits, and promotions for food service employees.

While this document focused on Good Food purchasing, we are happy to provide additional resources on other aspects of Good Food business implementation.



LIPSTICK
PEPPERS



Sweet, Peppery
Flavor

APPENDIX A: Glossary of Terms

Food Justice-Certified: a domestic fair trade label by the Agricultural Justice Project that certifies fair prices and terms for farmers and at the same time fair working conditions for all employees in certified operations. The standards are rights-based, such as the right to freely negotiate the terms of employment and freedom of association, and a verification model that ensures a safe space is created in which workers can exercise those rights. Other key provisions of the program include strong health and safety protections, including a preference for organic production and strong restrictions on the use of occupational toxins when a farm is not organic; clear grievance and complaints procedures including the right to appeal; and standards covering living wages, housing conditions, and more.

Source: <http://www.foodfirst.org/en/node/3098>

Website: www.agriculturaljusticeproject.org/standards.html

American Humane Certified: a voluntary, third-party animal welfare audit process based on five freedoms:

- Freedom from thirst and hunger – by ready access to fresh water and a diet to maintain full health and vigor
- Freedom from discomfort – by providing an appropriate environment including shelter and a comfortable resting area
- Freedom from pain, injury and disease – by prevention or rapid diagnosis and treatment
- Freedom to express normal behavior – by providing sufficient space, proper facilities and company of the animal’s own kind
- Freedom from fear and distress – by ensuring conditions and treatment which avoid mental suffering

Source: http://www.naturalnews.com/028552_humane_animals.html#ixzz27nxDdi1t

Website: <http://www.humaneheartland.org/our-standards>

Animal Welfare Approved: A consumer certification and labeling program which indicates that egg, dairy, meat or poultry products have been produced with the welfare of the farm animal in mind. The animals have access to the outdoors and are able to engage in natural behavior. No cages or crates may be used to confine the animals, and growth hormones and subtherapeutic antibiotics are disallowed. Some surgical mutilations, such as beak-mutilation of egg-laying hens, are prohibited, while others, such as castration without painkiller, are permitted. Compliance is verified through third-party auditing.

Biodynamic: a farming method that encourages the use of preparations made from fermented manure, minerals and herbs are used to help restore and harmonize the vital life forces of the farm and to enhance the nutrition, quality and flavor of the food being raised. Biodynamic practitioners also recognize and strive to work in cooperation with the subtle influences of the wider cosmos on soil, plant and animal health. Source/Website: <https://www.biodynamics.com/biodynamics.html>

Cage Free: This label indicates that the flock was able to freely roam a building, room, or enclosed area with unlimited access to food and fresh water during their production cycle. Beak cutting is permitted. There is no third-party auditing. Source: Agricultural Marketing Service, USDA; Humane Society

Certified Humane Raised & Handled: A consumer certification and labeling program which indicates that egg, dairy, meat or poultry products have been produced with the welfare of the farm animal in mind. Farm animal treatment standards include: Allow animals to engage in their natural behaviors; Raise animals with sufficient space, shelter and gentle handling to limit stress; Make sure they have ample fresh water and a healthy diet without added antibiotics or hormones. Producers also must comply with local, state and federal environmental standards. Processors must comply with the American Meat Institute Standards, a higher standard for slaughtering farm animals than the Federal Humane Slaughter Act. www.certifiedhumane.com

Certified Organic: Products must meet the federal organic standards as determined by a USDA approved certifying agency. Organic foods cannot be grown using synthetic fertilizers, chemicals, or sewage sludge; cannot be genetically modified; and cannot be irradiated. Organic meat and poultry must be fed only organically grown feed (without any animal byproducts) and cannot be treated with hormones or antibiotics. In order to bear the USDA “Certified Organic” seal, a product must contain 95 to 100 percent organic ingredients. Products that contain more than 70 percent, but less than 94 percent organic ingredients can be labeled “Made with Organic Ingredients,” but cannot use the USDA “Certified Organic” seal. Organic ingredients can be listed on the packaging of products that are not entirely organic. <http://www.ams.usda.gov/NOP/indexNet.htm>. While some small farmers grow their food using organic methods, they choose not to go through the certification process for economic or ideological reasons, so they cannot label their food “certified organic.”

CIW Fair Food Supplier Code of Conduct: a set of labor standards developed by the Coalition for Immokalee Workers designed to improve working conditions and give workers the ability to voice their concerns over safety, working conditions, and Code violations without fear of retribution. Growers are required to keep a proper time registration system, hire farm workers as employees and pay them wages and benefits directly, provide protective equipment and training, ensure breaks and opportunities for advancement, and implement proper workplace safety systems.

Source: <http://fairfoodstandards.org/code.html>

Cooperative: An autonomous association of persons united voluntarily to meet their common economic, social, and cultural needs and aspirations through a jointly owned and democratically controlled enterprise.

Conventionally Grown: Food grown using chemical fertilizers, pesticides, and herbicides. In most situations, default options are conventionally grown.

Equitable Food Initiative Certified: a program that certifies standards for working conditions, pesticide use and food safety. EFI's labor standards protect farm workers' health and safety; guarantee their freedom of association; provide fair compensation and conditions of employment; ensure non-discrimination and non-retaliation; create dispute settlement mechanisms; address housing conditions; establish a social premium; and cover workers on temporary visas. EFI's food safety standards address risks arising from land and water use, soil amendments, animal waste, and post-harvest packaging and transportation. Environmental standards focus on the safe management of pests, soil, water and habitat.

Website: <http://www.equitablefood.net>

Family Farm: A farm managed by a family or individual who owns the animals or land, receives a good portion of their livelihood from the farm, and participates in the daily labor to work and manage the farm. The USDA also defines a small family farm as having less than \$250,000 gross receipts annually.

Source: http://www.nifa.usda.gov/nea/ag_systems/in_focus/familyfarm_if_overview.html

Fair: All participants in the food supply chain receive fair compensation and fair treatment, free of exploitation.

Fair Trade: A certified label that guarantees that farmers and their workers receive a living wage and a fair price for their labor and their product, and that the product is produced in an ecologically sound manner.

Foodshed: Like a watershed (where the idea of the foodshed takes its inspiration), a foodshed measures the reach of the local landscape in terms of its food production capacities. A foodshed's size is determined by its "structures of supply," the regional, economic, political, and transportation systems that determine how food gets from farm to table. The Los Angeles Urban Rural Roundtable, convened by the Roots of Change in 2010, defined the Los Angeles foodshed as the two hundred mile radius around the Los Angeles urban core, from which the region draws much of its food to feed the local population. This concept continues to evolve. As a starting point, we refer to the 200-mile threshold as the Los Angeles regional foodshed.

Food Alliance Certified: Organization that certifies producers based on healthy and humane animal treatment with no added growth promotants or sub-therapeutic antibiotics, soil and water conservation, integrated pest, disease and weed management, pesticide risk reduction, wildlife habitat and biodiversity conservation, safe and fair working conditions. Website: <http://foodalliance.org/certification>

Free Range: A USDA-certified label that guarantees that animals (usually poultry) had room to move around and "access to the outdoors." These standards apply to poultry bred for eating only, not to hens that produce eggs. It does not guarantee that the animals ever went outside or that the outdoor space provided was good pasture.

Good Food: Good Food is defined by the Los Angeles Food Policy Council as food that is: 1) Healthy: a) Foods meet the Dietary Guidelines for Americans and provide freedom from chronic ailment; b) Food is delicious, safe, and aesthetically pleasing.; 2. Affordable: Foods that people of all income levels can purchase.; 3. Fair: a) All participants in the food supply chain receive fair compensation and fair treatment, free of exploitation.; b) High quality food is equitable and physically and culturally accessible to all; 4) Sustainable: Produced, processed, distributed, and recycled locally using the principles of environmental stewardship (in terms of water, soil, and pesticide management).

Genetically Modified Organisms (GMOs): In the context of food, GMOs are agricultural products (crops or animals) that have been genetically engineered to possess certain traits. Since there is minimal research on the long-term impacts that GMOs may have on the earth and human health, many organizations caution against use and consumption of GMOs. Organic products are, by definition, non-GMO.

Global Animal Partnership 5-Step Animal Welfare Rating standards: a tiered standards program that encourages higher welfare practices and systems to the benefit of farmers, consumers, retailers, and the animals. Step 1 prohibits cages and crates. Step 2 requires environmental enrichment for indoor production systems; Step 3, outdoor access; Step 4, pasture-based production; Step 5, an animal-centered approach with all physical alterations prohibited; and, finally, Step 5+, the entire life of the animal spent on an integrated farm.

Website: <http://www.globalanimalpartnership.org/the-5-step-program/>

Grassfed (American Grassfed Association (AGA) Certified):

This label ensures that animals have continuous access to pasture during the growing season (as opposed to being confined or eating grass out of a trough) and cannot be fed grain or grain products, which can diminish the nutritive benefits of grass feeding.

Grassfed (USDA Certified): Meat products derived from ruminant animals, e.g. beef cattle, dairy cattle, and lamb, may be approved to carry the USDA “grass-fed” label claim if the animal was fed a diet of grass and/or forage throughout its lifetime, with the exception of milk consumed prior to weaning. Animals cannot be fed grain or grain by-products and must have continuous access to pasture during the growing season (last frost in spring to first frost in fall). Use of hormones or antibiotics is not addressed.

Hazard Analysis & Critical Control Points (HACCP): HACCP is a management system in which food safety is addressed through the analysis and control of biological, chemical, and physical hazards from raw material production, procurement and handling, to manufacturing, distribution and consumption of the finished product.

Source: <http://www.fda.gov/food/foodsafety/hazardanalysiscriticalcontrolpointshaccp/default.htm>

Healthy: Foods meet the Dietary Guidelines for Americans and provide freedom from chronic ailment. Food is delicious, safe, and aesthetically pleasing.

Hormone Free: Milk that comes from cows who have not been treated with rBST, also known as rBGH or bovine growth hormone.

Integrated Pest Management (IPM): IPM growers practice a variety of techniques: they apply natural substances like kelp, rock powders, and compost to keep crops disease resistant. They monitor trees and set traps to capture insects. Ideally, IPM growers use pesticides only as a last resort, when pest damage would keep them from bringing in a profitable crop.

Large Scale Operation (LSO): Large scale operations include all levels of the food supply chain. The size is defined by type of operation:

- LSO Farm — a farm larger than 499 acres (NOTE: LSO Farm, as defined by the Good Food Purchasing Guidelines, is based upon the classification of farms by acreage in the 2007 USDA Agricultural Census).
- LSO Food Business — A business (including food processors) whose three (3) year average annual gross revenues exceed \$7 million (NOTE: Size of non-farm food business definition is based on City of Los Angeles Business Inclusion Program).

Living Wage: A wage that allows workers to meet their and their families’ basic needs, including housing, food, childcare, transportation, healthcare, clothing, and recreation costs for the area in which they live.

Local: The term “local” will vary depending on your location and what is available to you. The Los Angeles Food Policy Council has defined Los Angeles County’s foodshed to span 200 miles, ten counties and touch over 22 million people. This ten county region includes: Kern, Ventura, San Diego, Imperial, Riverside, Santa Barbara, San Luis Obispo, San Bernardino, Orange, and Los Angeles. The term “local” will vary depending on your location and what is available to you.

Los Angeles Business Inclusion Program Definitions:

- Small Business Enterprise (SBE): For the purpose of The Business Inclusion Program, Small Business Enterprise shall mean a business enterprise that meets the following criteria:

- A business (personal or professional services, manufacturer, supplier, and vendor) whose three (3) year average annual gross revenues does not exceed \$7 million.
- A business (construction contractors) whose three (3) year average annual gross revenues does not exceed \$14 million.
- Emerging Business Enterprise (EBE): For the purpose of this program, Emerging Business Enterprise shall mean a business enterprise whose three (3) year average annual gross revenues do not exceed \$3.5 million.

Source: <http://gsd.lacity.org/sms/BIP%20OUTREACH%20DOCUMENTATION%20&%20PROCESS.pdf>)

Marine Stewardship Council certified: an independent, non-profit organization that sets standards for sustainable fishing based on three principles:

- The fishing activity must be at a level which is sustainable for the fish population. Any certified fishery must operate so that fishing can continue indefinitely and is not overexploiting the resources.
- Fishing operations should be managed to maintain the structure, productivity, function and diversity of the ecosystem on which the fishery depends.
- The fishery must meet all local, national and international laws and must have a management system in place to respond to changing circumstances and maintain sustainability.

Website: <http://www.msc.org/>

Meatless Mondays campaign: non-profit initiative of The Monday Campaigns, in association with the Johns Hopkins' Bloomberg School of Public Health that encourages people, groups and organizations to not eat meat on Mondays to improve their health and the health of the planet. The campaign provides information and vegetarian recipes ideas based on USDA nutritional guidelines on their website.

Website: <http://www.meatlessmonday.com/>

Medium Scale Operation (MSO): Medium scale operations include all levels of the food supply chain. The size is defined by type of operation:

- MSO Farm — a farm between 180 and 499 acres (NOTE: MSO Farm, as defined by the Good Food Purchasing Guidelines, is based upon the classification of farms by acreage in the 2007 USDA Agricultural Census).

- MSO Food Business — a business (including food processors) whose three (3) year average annual gross revenues fall between \$3.5 million and \$7 million. (NOTE: Size of non-farm food business definition is based on City of Los Angeles Business Inclusion Program).

Non-GMO Project Verified: is a verification program that seeks to assist farmers, processors and manufacturers in avoiding the contamination of GMO's by progressively reducing the risk of GMO contamination. The Project requires practices and processes for controlling GMO contamination by these at-risk inputs and ingredients. Methods such as segregation, traceability, risk assessment, sampling techniques, and quality control management are emphasized. Website: <http://www.nongmoproject.org/>

Organic: Food grown without the use of chemical pesticides, herbicides, or fertilizers. Animals must be fed organic feed and cannot be given antibiotics or growth hormones. Organic foods may not be genetically modified or irradiated or contain artificial preservatives or additives. Organic meats must come from animals that are "free range."

PRiME (Pesticide Risk Mitigation Engine) score: an online tool that ranks pesticide products for impacts on birds, earthworms, small mammals, aquatic ecosystems and worker/bystander health and safety. This tool applies best available science to permit producers, advisors and regulatory professionals to compare different pest management scenarios for any commodity and select options with the fewest potential environmental and health hazards. Risk is presented on a low/moderate/high scale. Risk index scores below a 10% chance of an undesirable effect to be in the low risk category, where no further risk mitigation is needed. Realistically, 10% is within the margin of error for our risk models. Risk index scores between 10% and 50% fall into the moderate risk category where risk mitigation is recommended. Risk index scores above a 50% chance of an undesirable effect fall into the high-risk category.

Website: <http://ipmprime.org>

Procurement: The sourcing and purchasing of food to supply foodservice operations. Procurement involves identifying the food needs of the customer base for the foodservice operation, specifying product requirements, identifying suppliers, taking deliveries, inspecting and storing items, and, depending on the size of the operation, soliciting and evaluating bids and proposals, controlling inventory, and paying suppliers.

Protected Harvest certified: a points-based certification program is designed to ensure that crops have been raised with integrated pest management. The point system is used that rewards growers for implementing ecologically based practices in nine different management categories: field scouting, information sources, pest management decisions, field management decisions, weed management, insect management, disease management, soil and water quality, and storage management. A minimum number of points must be achieved in each category to qualify for certification. Website: <http://www.protectedharvest.org/>

“Raised without antibiotics” or “No antibiotics administered” (poultry and meat products): These USDA approved label claims imply that no antibiotics were administered to the animal at any point during its life. If an animal becomes sick and requires treatment, it should be segregated from other animals and sold as a conventional meat product. Source: http://www.fsis.usda.gov/Fact_Sheets/Meat_&_Poultry_Labeling_Terms/index.asp

Raised without added hormones or “No hormones added” (beef and lamb only): This USDA approved label claim implies that no added hormones were given to the animal at any point during its life. Most meaningful when used on beef or lamb products since the use of added hormones is prohibited in poultry and pork production. http://www.fsis.usda.gov/Fact_Sheets/Meat_&_Poultry_Labeling_Terms/index.asp

rBGH-free or rBST-free (dairy): Recombinant Bovine Growth Hormone is a genetically engineered artificial hormone, which is injected into cows to increase milk production. Labeling is voluntary. <http://www.foodandwaterwatch.org/take-action/consumer-tools/the-milk-tip/>

Small Scale Operation (SSO): Small scale operations include all levels of the food supply chain. The size is defined by type of operation:

— SSO Farm — a farm smaller than 180 acres. (NOTE: SSO Farm, as defined by the Good Food Purchasing Guidelines, is based upon the classification of farms by acreage in the 2007 USDA Agricultural Census. This is in contrast to the USDA definition of “small farm,” which is classified by gross sales less than \$250,000.)

— SSO Food Business — a business enterprise (including food processors) whose three (3) year average annual gross revenues do not exceed \$3.5 million.

(NOTE: Size of non-farm food business definition is based on City of Los Angeles Business Inclusion Program).

Source: A source includes not only the food supplier that the purchaser does business with directly, but also all prior links in the supply, processing and production chain, starting with the farm. The supplier who is working directly with the purchaser will take good faith measures to ensure that, to the best of the supplier’s knowledge, the supplier’s sources also comply with the Good Food Purchasing Guidelines.

Stewardship Index for Specialty Crops: a multi-stakeholder initiative to develop a system for measuring sustainable performance throughout the specialty crop supply chain. The Index does not provide standards, but instead provides a yardstick for measuring sustainable outcomes by offering a suite of outcomes-based metrics to enable operators at any point along the supply chain to benchmark, compare, and communicate their own performance. The four key environmental indicators in the latest version are soil health and the use of nutrients, energy and water. Website: <http://www.stewardshipindex.org/>

Sustainable: Systems and practices that can be continued indefinitely into the foreseeable future without reliance upon ongoing depletion of non-renewable resources (e.g., soil, energy, biological diversity) or widening social inequities (within and across communities, countries, or generations). With respect to agriculture, the term can include, but is not limited to or synonymous with, certified organic production practices.

Sustainable Seafood: Seafood that comes from sources, either farmed or wild, that can maintain production indefinitely without affecting the integrity of the surrounding ecosystem.

Transitional Organic: This label has been used in the past to mean that a farmer is using organic methods but has not reached the three-year pesticide-free requirement and cannot yet use the Certified Organic label. The USDA does not currently allow or sanction the use of this label for official marketing purposes.

USDA Farm Classification System

The USDA Economic Research Service (USDA-ERS) has developed a farm classification system to divide U.S. farms into eight mutually exclusive and more homogeneous groups. The farm typology focuses on “family farms,” or farms organized as proprietorships, partnerships, and family corporations that are not operated by a hired manager. To be complete, however, it also includes nonfamily farms. For more info, see <http://www.extension.org/pages/13823/usda-small-farm-definitions>

Value Chain: The Wallace Center differentiates food value chains from traditional supply food supply chains in the following way: New food value chains - 1) Operate as a series of win-win strategic partnerships rather than win-lose, interchangeable business deals; and 2) Differentiate products by attributes that traditional supply chains do not typically monitor or promote, such as the environmental and social benefits behind a particular producer’s practices.

Source: http://www.wallacecenter.org/our-work/Resource-Library/Innovative-Models/NGFN%20Case%20Study_Sycos%20Journey%20From%20Supply%20Chain%20to%20Value%20Chain.pdf

APPENDIX B: Good Food Purchasing Resource Guide

HEALTHY, LOCAL & SUSTAINABLE FOOD PURCHASING POLICIES & GUIDELINES

Restaurants

Green Seal™: GS 46 Restaurants & Food Service

<http://www.greenseal.org/GreenBusiness/Standards.aspx?vid=ViewStandardDetail&cid=0&sid=27>

SustainWeb: Ethical Eats (UK based restaurants and caterers committed to sourcing sustainable foods)

<http://www.sustainweb.org/ethicaleats/>

Green Restaurant Association's: Dine Green

<http://www.dinegreen.com/restaurants/standards.asp>

San Francisco Green Business Program Standards: Restaurants

http://sfgreenbusiness.org/images/stories/program%20standards%20PDFs/Restaurant_Checklist.pdf

Hospitals

Green Guide for Health Care™ Food Service Credits

http://www.noharm.org/us_canada/issues/food/planning.php#credits

Green Guide for Health Care™ Food Service Credits, "Environmentally Preferable Purchasing: Food Technical Brief"

http://noharm.org/lib/downloads/purchasing/EPP_Food_Tech_Brief_GGHC.pdf

Health Care Without Harm's Tools and Resources for Hospitals, Group Purchasing Organizations and Distributors

<http://www.healthyfoodinhealthcare.org/resources.php#purchasingguides>

Healthier Hospitals Initiative

<http://healthierhospitals.org/hhi-challenges/healthier-food>

Kaiser Permanente: Fact Sheet on Sustainable Food Purchasing Policy

<http://xnet.kp.org/newscenter/aboutkp/green/stories/2011/110811sustainablefood.html>

Partnership for a Healthier America

<http://www.ahealthieramerica.org/#!/about-the-partnership>

Universities

University of California Policy on Sustainable Practices: Sustainable Foodservices Policy (page 19) http://www.universityofcalifornia.edu/sustainability/documents/policy_sustain_prac.pdf

Yale Sustainable Food Purchasing Guide http://www.yale.edu/sustainablefood/purchasing_guide_002.pdf.pdf

Yale Sustainable Food Purchasing Guidelines

http://www.yale.edu/sustainablefood/food_purchasing.html

Emory University's Sustainable Food Initiative <http://sustainability.emory.edu/page/1008/Sustainable-Food>

Bon Appetit: General Sustainability Principles

<http://www.cafebonappetit.com/>

K-12 Schools

Washington D.C: Healthy Schools Act of 2010

<http://dchealthyschools.org/wordpress/wp-content/uploads/2011/11/Healthy-Schools-Act-as-Amended-20110810.pdf>

Local Food Procurement for San Diego Unified School District

<http://www.sandi.net/site/Default.aspx?PageID=993>

Local Fruit and Vegetable Sourcing in St. Paul's Public Schools- Lessons Learned and RFP

<http://food-hub.org/files/resources/>

Sample Purchasing Guidelines – "Specs" Large Scale Scratch Cooking Environment- Chef Ann Cooper, Berkeley Unified School District

http://www.thelunchbox.org/sites/default/files/SAMPLE_PURCHASING_GUIDELINES2.pdf

Primer on geographic Preference: Potential, Pitfalls and Proper Procedures – School Food FOCUS

<http://www.schoolfoodfocus.org>

Alliance for a Healthier Generation

<http://www.healthiergeneration.org/companies.aspx?id=5657>

National Farm to School Network's list of resources on buying and selling local foods

<http://www.farmtoschool.org/publications.php?pt=buys>

Federal, State and Municipal Government

General Services Agency: Health and Sustainability Guidelines for Federal Concessions and Vending Operations
<http://www.gsa.gov/portal/content/104429>

Massachusetts State Agency Food Standards

<http://www.mass.gov/eohhs/docs/dph/com-health/nutrition-phys-activity/eo509-state-agency-food-standards.pdf>

City and County of San Francisco, Executive Directive: Healthy and Sustainable Food for San Francisco

http://www.sfgov3.org/ftp/uploadedfiles/sffood/policy_reports/MayorNewsomExecutiveDirectiveonHealthySustainableFood.pdf

New York City Agency Food Standards

http://www.cspinet.org/new/pdf/nyc_agency_food_standards.pdf

General Background Resources

Sustainable Food Policy- A Guide to Developing Sustainable Food Purchasing Policy
<http://www.sustainablefoodpolicy.org/>

Public Health Law and Policy: “Understanding Healthy Procurement: Using Government’s Purchasing Power to Increase Access to Healthy Food”

http://www.phlpnet.org/sites/phlpnet.org/files/Understanding_Healthy_Procurement_2011.pdf

UC Sustainable Agriculture Research & Education Program, Agricultural Sustainability Institute, UC Davis: “Emerging Local Food Initiatives in Northern California Hospitals”

http://www.sarep.ucdavis.edu/CDPP/fti/Farm_To_Hospital_WebFinal.pdf

The Johns Hopkins Center for a Livable Future Health Care and Without Harm: “Balanced Menus: A Pilot Evaluation of Implementation in Four San Francisco Bay Area Hospitals”

<http://www.jhsph.edu/bin/k/m/BMCReportFinal.pdf>

Centers for Disease Control and Prevention (CDC): “Improving the Food Environment Through Nutrition Standards: A guide for government procurement”

http://www.cdc.gov/salt/pdfs/dhdsp_procurement_guide.pdf

Michigan Good Food Work Group Report Series: “Institutional Food Purchasing”

<http://mlui.org/downloads/InstFoodPurchasingReport.pdf>

LEARN MORE ABOUT GOOD FOOD SOURCING

Local

USDA's List of Certified Farmers' Markets

<http://apps.ams.usda.gov/FarmersMarkets/Default.aspx>

See Appendix C for list of local product availability in LA (distributors and processors)

Environmental Sustainability

Consumer Reports

Greener Choices: Eco-Labels Center

<http://www.greenerchoices.org/eco-labels/productArea.cfm?ProductCategoryID=174>

Food Alliance, Institute for Agriculture & Trade Policy, Association for the Advancement of Sustainability in Higher Education, Healthcare Without Harm

Third Party Certifiers for Sustainability in Food & Agriculture

<http://www.sustainablefoodpolicy.org/third-party-certifications-for-identifying-sustainably-produced-foods>

Natural Resources Defense Council

Label Lookup

<http://www.nrdc.org/living/labels/food.asp>

Meatless Monday Campaign Toolkits

<http://www.meatlessmonday.com/spread-the-movement/>

CCOF Certified Organic

CCOF's Organic Online Directory

http://www.ccof.org/cgi-bin/organicdirectory_search.cgi

USDA Certified Organic

www.ams.usda.gov/nop/

Food Alliance Certified

Online directory of certified producers and handlers

<http://foodalliance.org/client-search>

Non-GMO Project Verified

<http://www.nongmoproject.org/take-action/search-participating-products/>

Stewardship Index for Specialty Crops

<http://www.stewardshipindex.org/>

Sustainable Seafood

Blue Ocean Institute

Offers Ocean and seafood sustainability education for chefs<http://www.blueocean.org>

Monterey Bay Seafood Watch List

http://www.montereybayaquarium.org/cr/SeafoodWatch/web/sfw_factsheet.aspx

Good Catch...The Essentials: Helping You Navigate Seafood Sustainability

http://www.goodcatch.org.uk/site_media/uploads/Good_Catch...the_essentials_FINAL.pdf

Marine Stewardship Council

<http://www.msc.org/>

Marine Conservation Society

Buyers guide to sustainable seafood<http://www.fishonline.org/>

The Institute for Fisheries Resources

List of local fish seasonality<http://www.ifrfish.org/where/los-angeles-area>**Valued Workforce**

United Farm Workers

List of farms with union contracts:http://www.ufw.org/_page.php?menu=organizing&inc=orga_label.html

Agricultural Justice Project's Standards

<http://www.agriculturaljusticeproject.org/AJPStandardsJuly2010Final.pdf>

Agricultural Justice Project's Toolkit for Farmers

Sample labor policies and other resources to help farmers meet standardshttp://www.agriculturaljusticeproject.org/full_farmer_toolkit.pdf

Equitable Food Initiative

Partnership among businesses and organizations that have come together to develop standards, training processes and a certification to protect farm workers and produce safer, healthier food.<http://www.equitablefood.net/#!home/mainPage>

Bon Appetit: Code of Conduct for Sustainable Tomato

Suppliers <http://www.bamco.com/uploads/documents/CODE%20OF%20CONDUCT%20FOR%20SUSTAINABLE%20TOMATO%20SUPPLIERS%20.pdf>

Domestic Fair Trade Association

DFTA is engaged in a process of developing criteria for domestic fair trade standards. Draft DFTA criteria and instructions for evaluation:<http://www.thedfta.org/index.php?c=evaluation>

Food Chain Workers Alliance

Statement on Social Certification

http://foodchainworkers.org/?page_id=232

Restaurant Opportunities Center

*National Diner's Guide**Consumers guide provides information on the wage, benefits, and promotion practices of the 150 most popular restaurants in America, including several high-road restaurants in Los Angeles.*<http://rocunited.org/dinersguide/>

Fair World Project

<http://fairworldproject.org/>**Animal Welfare**

Global Animal Partnership

Recognizes and rewards producers for their welfare practices and promotes and facilitates continuous improvement. Standards listed here:<http://www.globalanimalpartnership.org/the-5-step-program/our-standards/>

Animal Welfare Approved

Online directory of certified farms<http://www.animalwelfareapproved.org/product-search/>

Humane Farm Animal Care/Certified Humane Raised and Handled®

Online directory<http://www.certifiedhumane.org/index.php?page=where-to-buy>

AGA Grass-Fed

AGA Producer Profiles<http://www.americangrassfed.org/producer-profiles/>

Animal Welfare Approved

*Food Labeling for Dummies**A guide to common food label terms and claims*http://www.animalwelfareapproved.org/wp-content/uploads/2012/08/Food-Labeling-For-Dummies-6_high-res.pdf

Nutrition

U.S. Department of Agriculture (USDA): *Dietary Guidelines for Americans*

<http://www.cnpp.usda.gov/DGAs2010-PolicyDocument.htm>

Harvard School of Public Health: *Healthy Eating Plate*

<http://www.hsph.harvard.edu/nutritionsource/healthy-eating-plate/>

USDA: *My Plate*

<http://www.choosemyplate.gov/print-materials-ordering/dietary-guidelines.html>

APPENDIX C: Local Product Availability (Los Angeles)

Los Angeles wholesale distribution firms with locally sourced products:

California Produce Wholesalers

6818 Watcher St.
Commerce, CA 90040
Telephone: (800) 460-9193
Fax: (562) 928 3090

<http://www.californiaproducewholesalers.com/>



FreshPoint Southern California

Locally Grown Division
155 N. Orange Avenue
City of Industry, CA 91744

<http://www.freshpoint.com>



Gold Star Foods

3781 E. Airport Drive
Ontario, Ca. 91761
Telephone: (800) 540-0215
Fax: (866)802-1997

<http://www.goldstarfoods.com/default.asp>



Heath & Lejeune

1417 South Eastman Avenue
Commerce, CA 90023
Telephone: (213) 614-1909

<http://soulllyorganic.com/>



L.A. Specialty Produce

13527 Orden Drive
Santa Fe Springs, CA 90670
Telephone: (562) 741-2200
Fax: (562) 741-2907

<http://www.laspecialty.com/index.html>



Sunrise Produce Company

1400 Goodrich Blvd
Commerce, CA 90022
Telephone: (323) 726-3838

<http://www.sunriseproduce.com/index.html>



West Central Produce

2020 East 7th Place
Los Angeles, CA 90021
Telephone: (800) 464-8349

www.westcentralproduce.com



Worldwide Produce

1661 McGarry St.
Los Angeles, CA 90021
Telephone: (800) 300-2737
Fax: (213) 741-1777

<http://www.wwproduce.com/>



Processing of locally sourced produce:

Field Fresh Foods

Locally Fresh Foods
14805 South San Pedro Street
Gardena, CA 90248
Telephone: (800)411-0588

<http://www.fieldfre>





Tomatillo
\$3/lb

Roma
Tomatoes
\$2.50/lb

Small
Pumpkin
\$1.50/lb
Large
Pumpkin
\$2.00/lb

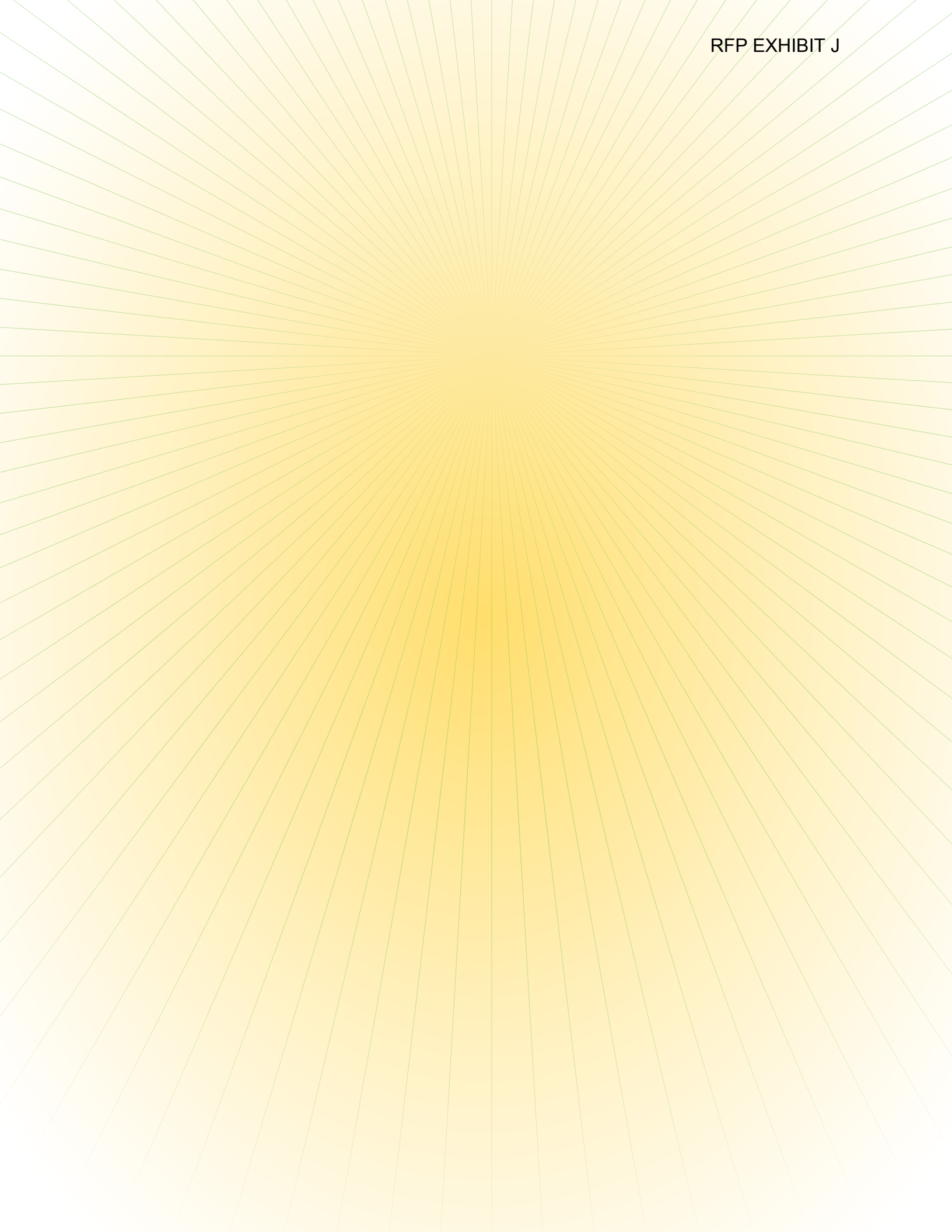

www.goodfoodla.org

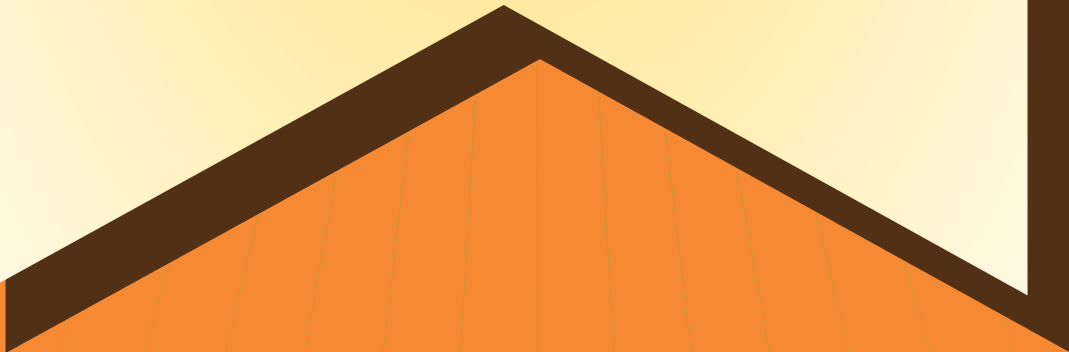

Baseline Data Collection Plan for Good Food Purchasing Institutions

Year 1

The list below details all deliverables requested in Year One of the Good Food Purchasing Policy. Information collected will help assess your baseline purchasing practices and will be used to develop goals and action plans for continued progress. Information will be updated annually. All forms will be provided in toolkit and electronically. Documents should be submitted to Colleen McKinney at cmckinney@goodfoodla.org.

DELIVERABLE	DEADLINE
✓ Attend Semi-Annual Good Food Purchasing Technical Assistance Meeting	March 2014
✓ Sign Good Food Purchasing Pledge	(Within one month)
✓ Submit Food Service Operations Overview Form <ol style="list-style-type: none"> 1. Total annual dollar amount of food purchases by food category (including beverages) 2. Food service contracts terms (i.e. renewal dates) and vendor names 3. Existing monitoring and compliance plans 	Within one month of signing Good Food Purchasing Pledge
✓ Submit copy of signed Contractor Code of Conduct forms from food service vendors acknowledging that all subcontractors and suppliers comply with domestic labor law (including state and local) in countries where they produce goods and services, as well as the core International Labour Organization (ILO) standards.	Within one month of signing Good Food Purchasing Pledge
✓ Complete Baseline Assessment: Nutrition Guidelines in Food Service Institutions	Within one month of signing Good Food Purchasing Pledge
✓ Provide three-month detailed purchasing inventory for five food categories (see Good Food Purchasing Tracking form): <ul style="list-style-type: none"> • Five categories include: 1) produce; 2) milk/dairy; 3) meat/poultry; 4) whole grains & legumes; 5) seafood • For each five food categories, provide following information for each product purchased: 1) food type; 2) volume; 3) cost; and 4) source (brand or label – or farm if possible) • Include up to three months of data 	Within two months of signing Good Food Purchasing Pledge
✓ Complete First Draft of Five-Year GFPP Action Plan (see template)	Within four months of signing Good Food Purchasing Pledge
✓ Attend Semi-Annual Good Food Purchasing Technical Assistance Meeting	Summer 2014
✓ Submit final Five-Year GFPP Action Plan to LAFPC	Within eight months of signing Good

	Food Purchasing Pledge
--	------------------------

Ongoing Data Collection Plan for Good Food Purchasing Institutions
Years Two through Five

DELIVERABLE	DEADLINE
<ul style="list-style-type: none"> ✓ Submit quarterly inventory of food purchases by product category <ul style="list-style-type: none"> ▪ Five categories include: 1) produce; 2) milk/dairy; 3) meat/poultry; 4) whole grains & legumes; 5) seafood ▪ For each five food categories, provide following information for each product purchased: 1) food type; 2) volume; 3) cost; and 4) source (to farm level) 	January April July October
<ul style="list-style-type: none"> ✓ Attend Semi-Annual Good Food Purchasing Technical Assistance Meeting 	Winter
<ul style="list-style-type: none"> ✓ Update Food Operations Overview, Nutrition Assessment and/or Contractor Code of Conduct forms as necessary 	March
<ul style="list-style-type: none"> ✓ Attend Semi-Annual Good Food Purchasing Technical Assistance Meeting 	Summer
<ul style="list-style-type: none"> ✓ Submit Report on Policies, Practices and Progress to LAFPC 	August
<ul style="list-style-type: none"> ✓ LAFPC submits Annual Report on Implementation to City Administrative Officer 	October

Please submit this form to Colleen McKinney (cmckinney@goodfoodla.org).

1. Total annual dollar amount of food purchases by food category (including beverages).

Annual Food Purchases by Product Category	
Food Category	Annual Purchase Amount (\$)
Fruit & Vegetables <ul style="list-style-type: none">• <i>Fresh</i>• <i>Frozen</i>• <i>Canned</i>	
Milk & Dairy	
Meat & Poultry	
Seafood	
Grains & Legumes (beans, rice, quinoa etc)	
Other Products (packaged foods, bakery items etc)	
Beverages	
TOTAL ANNUAL FOOD PURCHASES	

2. List all food service contracts terms (i.e. renewal dates) and vendor names.

Department Food Service Contracts	Vendor Name	Contract Renewal Dates

3. List and describe any existing monitoring and compliance plans included in current contracts (use as much space as needed).

**CITY OF LOS ANGELES
CONTRACTOR CODE OF CONDUCT**

The City of Los Angeles has long supported the premise that employers should fairly compensate employees, that the health and safety of workers should be protected, and that no form of discrimination or abuse should be tolerated. Experience indicates that laws and regulations designed to safeguard basic tenets of ethical business practices are disregarded in some workplaces, commonly referred to as "sweatshops."

In its role as a market participant that procures equipment, goods, materials and supplies, the City seeks to protect its interests by assuring that the integrity of the City's procurement process is not undermined by contractors who engage in sweatshop practices and other employment practices abhorrent to the City. When the City inadvertently contracts with these contractors, the City's ethical contractors are placed at a distinct competitive disadvantage. Many times ethical contractors are underbid by unscrupulous contractors in competition for City contracts. These ethical contractors may be dissuaded from participating in future procurement contracts.

The City's proprietary contracting interests are served by doing business with contractors who make a good faith effort to ensure that they and their subcontractors shun sweatshop practices and adhere to workplace and wage laws. Seeking to protect these municipal interests, the City requires that all contractors subject to the Sweat-free Procurement Ordinance certify that they and, to the best of their knowledge, their subcontractors will comply with the City's Contractor Code of Conduct and to promise the following:

- (a) To comply with all applicable wage, health, labor, environmental and safety laws, legal guarantees of freedom of association, building and fire codes, and laws and ordinances relating to workplace and employment discrimination.
- (b) To comply with all human and labor rights and labor obligations that are imposed by treaty or law on the country in which the equipment, supplies, goods or materials are made or assembled, including but not limited to abusive forms of child labor, slave labor, convict or forced labor, or sweatshop labor.
- (c) To take good faith measures to ensure, to the best of the contractor's knowledge, that the contractor's subcontractors also comply with the City's Contractor Code of Conduct.
- (d) To pay employees working on contracts for garments, uniforms, foot apparel, and related accessories a procurement living wage, meaning for domestic manufacturers a base hourly wage adjusted annually to the amount required to produce, for 2,080 hours worked, an annual income equal to or greater than the U.S. Department of Health and Human Services most recent poverty guideline for a family of three plus an additional 20 percent of the wage level paid either as hourly wages or health benefits. For manufacturing operations in countries other than the United States, a procurement living wage which is comparable to the wage for domestic manufacturers as defined above, adjusted to reflect the country's level of economic development by using the World Bank's Gross National Income Per Capita Purchasing Power index.

CERTIFICATION UNDER PENALTY OF PERJURY

I certify under penalty of perjury under the laws of the State of California that I have read and understood the City's Contractor Code of Conduct and agree to comply with its requirements.

Signature of Officer or Authorized Representative Date

Print Name and Title of Authorized Representative

Print Company Name, Address and Phone Number

Value 5: Nutrition – Promote health and well-being by offering generous portions of vegetables, fruits, and whole grains; reducing salt, added sugars, fats and oils; and by eliminating artificial additives.

Baseline Assessment: Nutrition Guidelines in Food Service Institutions

This baseline assessment will measure your institution's compliance with the nutrition category of the Good Food Purchasing Guidelines. All nutrition goals listed below may not apply to all types of food service institutions. Each food service institution will be eligible for points towards the Good Food Purchasing Pledge based on the total potential applicable points for that type of food service venue. LAFPC will work with each institution individually on their institution's pledge criteria. These nutrition goals were developed from reputable sources including the United States Department of Agriculture (USDA), the Food and Drug Administration (FDA), as well as other leading health organizations. The below nutrition goals will be reviewed and revised periodically to ensure they meet current dietary science and take into consideration program implementation.

Please answer each question below. If box is checked YES, please provide detail on how your institution meets this guideline. If NO, please state why not and if box is checked N/A, please explain why. **Send your self-assessment to Colleen McKinney at cmckinney@goodfoodla.org.**

Nutrition Goals	Yes/No/NA	Description: <i>If box is checked YES, please provide detail on how institution meets this guideline. If NO, please state why not. If you checked N/A please explain why.</i>
1. Do fruits, vegetables, and whole grains account for at least 25% of food purchases?	Y <input type="checkbox"/> N <input type="checkbox"/> N/A <input type="checkbox"/>	
2A. Are seasonal fruits sourced to ensure best taste, quality, and price?	Y <input type="checkbox"/> N <input type="checkbox"/>	

	N/A <input type="checkbox"/>	
2B. Are seasonal vegetables sourced to ensure best taste, quality, and price?	Y <input type="checkbox"/> N <input type="checkbox"/> N/A <input type="checkbox"/>	
3A. Does your institution to the greatest extent possible prioritize the purchase of whole fruit before purchasing frozen and/or canned fruit in its own juice with no sugars added?	Y <input type="checkbox"/> N <input type="checkbox"/> N/A <input type="checkbox"/>	
3B. When fruits are whole, are they purchased without added sugar?	Y <input type="checkbox"/> N <input type="checkbox"/> N/A <input type="checkbox"/>	
3C. Is canned fruit in its own juice with no sugars added?	Y <input type="checkbox"/> N <input type="checkbox"/> N/A <input type="checkbox"/>	
4A. Does your institution to the greatest extent possible prioritize the purchase of whole vegetables without added sodium and fat before purchasing frozen and/or canned vegetables that are low sodium or have "no salt added"?	Y <input type="checkbox"/> N <input type="checkbox"/> N/A <input type="checkbox"/>	

4B. Are vegetables purchased whole, without added sodium and fat?	Y <input type="checkbox"/> N <input type="checkbox"/> N/A <input type="checkbox"/>	
4C. Are canned vegetables low sodium (per FDA definitions) ¹ or have “no salt added”?	Y <input type="checkbox"/> N <input type="checkbox"/> N/A <input type="checkbox"/>	
5. Does your institution prioritize the purchase of whole-grain, high-fiber options ² ?	Y <input type="checkbox"/> N <input type="checkbox"/> N/A <input type="checkbox"/>	
6. Does your institution prioritize offering plant-based main dishes at each meal service ³ ?	Y <input type="checkbox"/> N <input type="checkbox"/> N/A <input type="checkbox"/>	
7. If meat is offered, is the purchase of “extra lean” (total fat ≤ 5%) and “lean” (total fat ≤ 10%) meat such as skinless chicken, turkey, ground beef, and pork prioritized?	Y <input type="checkbox"/> N <input type="checkbox"/> N/A <input type="checkbox"/>	

¹ Low sodium is defined as 140 mg or less per Reference Amount Customarily Consumed (RACC)

² Whole grain is listed as the first or second ingredient; 2 grams or more of fiber/serving

³ Recommend plant-based dishes to include fruits, vegetable, beans, and legumes

8. If meat is offered, is the purchase of processed meats ⁴ minimized?	Y <input type="checkbox"/> N <input type="checkbox"/> N/A <input type="checkbox"/>	
9A. If dairy products are offered, is the purchase of Fat-Free or Low Fat dairy products (1% milk fat or less with no added sweeteners) prioritized?	Y <input type="checkbox"/> N <input type="checkbox"/> N/A <input type="checkbox"/>	
9B. If milk is offered, are soy, rice, or other non-dairy milk alternatives without added sweeteners available?	Y <input type="checkbox"/> N <input type="checkbox"/> N/A <input type="checkbox"/>	
10A. If juice is offered, is the purchase of juice that is 100% fruit juice with no added sweeteners prioritized?	Y <input type="checkbox"/> N <input type="checkbox"/> N/A <input type="checkbox"/>	
10B. Is the purchase of all vegetable juice to be Low Sodium as per FDA definitions ⁵ prioritized?	Y <input type="checkbox"/> N <input type="checkbox"/> N/A <input type="checkbox"/>	

⁴ If processed meats are offered, recommend using only products with no more than 480 mg per 2 oz.

⁵ Low Sodium is 140 mg or less per RACC

<p>11. Do at least 50% of available beverage choices (excluding 100% fruit and Low Sodium vegetable juices and Fat Free or Low Fat milk with no added sweeteners) contain ≤ 25 calories per 8 ounces?</p>	<p>Y <input type="checkbox"/></p> <p>N <input type="checkbox"/></p> <p>N/A <input type="checkbox"/></p>	
<p>12. Is drinking water (preferably cold tap water in at least 12 ounce cup sizes) offered?</p>	<p>Y <input type="checkbox"/></p> <p>N <input type="checkbox"/></p> <p>N/A <input type="checkbox"/></p>	
<p>13. Has your institution eliminated the use of hydrogenated and partially hydrogenated oils for cooking or baking?</p>	<p>Y <input type="checkbox"/></p> <p>N <input type="checkbox"/></p> <p>N/A <input type="checkbox"/></p>	
<p>14. Are Low Fat and/or Low Calorie and/or Low Sodium condiments offered as per FDA definitions⁶?</p>	<p>Y <input type="checkbox"/></p> <p>N <input type="checkbox"/></p> <p>N/A <input type="checkbox"/></p>	
<p>15. Has your institution committed to developing and implementing a gradual sodium reduction plan* that meets current Dietary Guidelines for Americans (DGA) standards?</p> <p>* A gradual sodium reduction plan is a guide to assist in reducing sodium gradually over time by a set of defined criteria, in food procured, sold, or distributed by any food service entity; this can include restaurants, snack shops, vending, cafeterias, and other types of food service venues.</p>	<p>Y <input type="checkbox"/></p> <p>N <input type="checkbox"/></p> <p>N/A <input type="checkbox"/></p>	

⁶ Low-Fat is 3 g or less per RACC (and per 50g if RACC is small); Low Sodium is 140 mg or less per RACC (and per 50g if RACC is small); Low Calorie is 40 calories or less per RACC (and per 50g if RACC is small).

<p>16. Does all pre-packaged food have zero grams <i>trans</i> fat per serving (as labeled)?</p>	<p>Y <input type="checkbox"/></p> <p>N <input type="checkbox"/></p> <p>N/A <input type="checkbox"/></p>	
<p>17. Has your institution eliminated the use of deep frying?</p>	<p>Y <input type="checkbox"/></p> <p>N <input type="checkbox"/></p> <p>N/A <input type="checkbox"/></p>	
<p>18. Is the preparation of all protein, including fish, poultry, meat, or meat alternatives in a low fat way (broiling, grilling, baking, poaching, roasting, or steaming) prioritized?</p>	<p>Y <input type="checkbox"/></p> <p>N <input type="checkbox"/></p> <p>N/A <input type="checkbox"/></p>	
<p>19. Are water, diet drinks (drinks that do not exceed 25 cal. per 8oz), 100% fruit juice without added sweeteners, Low Sodium vegetable juices, Fat Free or Low Fat dairy products with no added sweeteners, and milk alternative products displayed in eye level sections of beverage cases? (if applicable)</p>	<p>Y <input type="checkbox"/></p> <p>N <input type="checkbox"/></p> <p>N/A <input type="checkbox"/></p>	
<p>20. Has your institution prioritized the location of fruit and/or non-fried vegetables at convenient, high-visibility locations (including at front of cafeteria lines) and within reach of checkout registers? (if applicable)</p>	<p>Y <input type="checkbox"/></p> <p>N <input type="checkbox"/></p> <p>N/A <input type="checkbox"/></p>	
<p>21. Are fruit with no-added sweeteners and non-fried vegetable offerings highlighted with signage?</p>	<p>Y <input type="checkbox"/></p> <p>N <input type="checkbox"/></p> <p>N/A <input type="checkbox"/></p>	

22. Has your institution removed candy bars, cookies, chips and beverages with added sugars (such as soda, sports and energy drinks) from checkout register areas/point-of-purchase? (if applicable)	Y <input type="checkbox"/> N <input type="checkbox"/> N/A <input type="checkbox"/>	
23. Does your institution's menu list the nutritional information for each item using the federal menu labeling requirements under the Patient Protection and Affordable Care Act of 2010 as a guide?	Y <input type="checkbox"/> N <input type="checkbox"/> N/A <input type="checkbox"/>	
24A. Does your institution prioritize the use of 10' or smaller plates for all meals?	Y <input type="checkbox"/> N <input type="checkbox"/> N/A <input type="checkbox"/>	
24B. Does your institution prioritize making available reduced-size portions of at least 25% of menu items offered?	Y <input type="checkbox"/> N <input type="checkbox"/> N/A <input type="checkbox"/>	
24C. Does your institution prioritize offering reduced-size portions at a lower price than regular-sized portions ⁷ ?	Y <input type="checkbox"/> N <input type="checkbox"/> N/A <input type="checkbox"/>	

⁷ Reduced-sized portions are no more than 70% of the weight, measured in grams, of a regular-size portion of the same menu item.

24D. Are other portion control strategies prioritized in your institution?	Y <input type="checkbox"/> N <input type="checkbox"/> N/A <input type="checkbox"/>	
25. Does your institution have a worksite wellness program including nutrition education for employees and/or patrons?	Y <input type="checkbox"/> N <input type="checkbox"/> N/A <input type="checkbox"/>	

FRUIT & VEGETABLE PURCHASING DATA

(insert quarter, year)

Food Type	Total Order Information					Distributor
	# Cases	\$/Case	Total Cost	Product Detail (Example: brand, grower, supplier)	Location	
Total Fruits & Vegetables			\$0.00			

Five-Year GFPP Action Plan | TEMPLATE

The tiered, points based scoring system outlined in the Good Food Purchasing Guidelines allows participants to choose which level of commitment best suits the Good Food goals of their organization. The guidelines require that a baseline be met for each value, but an institution can receive additional points by making even greater commitments in each value category. Participants are awarded one to five stars based on their total score. To maintain their star rating over time, participating institutions are expected to increase the amount of Good Food they purchase each year.

In Year One of the program, Good Food Purchasing Institutions (GFPI) will develop a five-year action plan that describes their purchasing goals and objectives, based on the baseline purchasing practices measured at the time of pledge adoption. The action plan should include measurable deliverables and benchmarks from Years One through Five. The multi-year action plan will serve as a guide for future annual progress reports. The components of a successful action plan, including the any forms to be submitted, are described below. **Submit final action plan and chart to Colleen McKinney at cmckinney@goodfoodla.org.**

SECTION ONE: Year One – Baseline Assessment

Introduction & Purpose

Summarize in a few sentences your institution's interest and involvement in the Good Food Purchasing Program.

Food Service Operations Overview (SUBMIT FORM)

Using the *Food Service Operations Overview* form, describe your operation, including:

Total purchases for each food category: fruits & vegetables, milk & dairy, meat & eggs, seafood, grains & legumes, other products (packaged foods, bakery products, etc.), and beverages.

- Total annual food purchases
- Food service contract terms (i.e. renewal dates) and vendor names
- Existing monitoring & compliance plans included in contracts

GFPP Tracking Sheet (SUBMIT FORM)

Using the *GFPP Tracking Sheet* or the inventory sheet supplied by your vendor(s), provide the following information for each product:

- Food type
- Volume purchased
- Cost per unit
- Source: include brand or label and plant location. Wherever possible, include the name of the farm or ranch where the item was produced
- Any known certifications or product claims associated with each product

Summary of Current Best Practices & Recent Achievements

Highlight any existing best practices or key procurement achievements within your institution. This may include:

- Recent product shifts or commitments (e.g. 100% cage free eggs, direct relationship with local growers)
- Existing healthy and/or sustainable food service initiatives (e.g. trayless dining, compostable dishware, Healthy Picks program)
- Staff trainings or continued learning opportunities related to food service, culinary arts, nutrition, etc.

Current Challenges

In your work to improve your food service operation, what have been the greatest challenges to success? What obstacles might continue to slow progress?

SECTION TWO: Years Two through Five

2-5 Year Plan Goals

Outline the institution's overall long-term goals for the Good Food Purchasing Program (e.g. earn three-star rating by third year of program).

Objectives & GFPP Five-Year Action Plan Chart (SUBMIT FORM)

Identify the objectives your institution will focus on to reach your desired rating (i.e. achieve Level 3 Environmental Sustainability by Year Two, Level 2 in Valued Workforce by Year Four, and maintain Level 1 in all other categories). In each category section, identify any changes you will make to your purchasing that will allow you to meet your desired level in that category. For each of the five value categories, explain your institution's objective, benchmarks, and timeline for completion (see template attached).

Template: GFPP Five-Year Action Plan Chart – For Good Food Purchasers

Target: The Good Food Purchasing Pledge harnesses the purchasing power of major institutions to encourage greater production of sustainably produced food, healthy eating habits, respect for workers' rights, humane treatment of animals and support for the local business economy by providing new opportunities for small and mid-sized farmers and job creation along the supply chain.

Directions: Use this document as a planning guide for implementing the Good Food Purchasing Guidelines. For each value, you only need to choose one objective from one level. Each Level corresponds with the numeric value. For example, achieving Level 1 would earn you 1 point, Level 2 = 2 points, and so on. If your institution is unable to reach the baseline level for any value category in Year 1, you may submit a plan detailing your goals for achieving baseline compliance within one year.

Value 1: Local Economies – Support small and mid-sized agricultural and food processing operations within the local area or region

	Objective	Benchmarks	Activities	Timeframe	Points
Level 1 = 1 Point	<p>15% annual average of total cost of food purchases comes from sources that are:</p> <ul style="list-style-type: none"> ▪ Within 200 miles (or 10 SoCal counties) and large scale operations (>500 acre farms) OR ▪ In California AND medium scale operations (180-499 acre farms) OR ▪ Outside of California AND small scale operations (<180 acre farms) <p>25% annual average of total cost of food purchases by Year 5.</p>				
Level 2 = 2 Points	<p>15% annual average of total cost of food purchases comes from sources that are:</p> <ul style="list-style-type: none"> ▪ Local within 200 miles (or 10 SoCal counties) AND medium scale operations OR ▪ Within California AND small scale operations <p>25% annual average of total cost of food purchases by Year 5.</p>				
Level 3 = 3 Points	<p>15% annual average of total cost of food purchases comes from sources that are:</p> <ul style="list-style-type: none"> ▪ Local within 200 miles (or 10 SoCal counties) AND small scale operations <p>25% annual average of total cost of food purchases by Year 5.</p>				
Extra Points = 1 Point Each	5% of annual average of total cost of food purchases comes from microenterprise farms (<100 acres) and located within 200 miles.				
	1% of annual average of total cost of food purchases is grown/raised and processed in Los Angeles County.				
	Food is purchased directly from farmer-owned businesses.				
	Food is purchased from women, minority, disabled, or veteran-owned food businesses (farms/operations).				
	50% of total cost of food purchases comes from small and mid-sized food operations within the local area or region.				
	At least 25% of prepared seafood sourced from small and or local fleets.				

Total Local Economies Points:

Value 2: Environmental Sustainability – Source from producers that employ sustainable production systems

	Objective	Benchmarks	Activities	Timeframe	Points
Level 1 = 1 Point	<p>Overall: 15% annual average of total cost of food purchases, with a goal of increasing at least 2% per year will come from Level 1 environmentally sustainable sources; No seafood purchased should be listed as “Avoid” in the Monterey Bay Aquarium’s most recent Seafood Watch Guide. 25% annual average of total cost of food purchases by Year 5.</p> <ul style="list-style-type: none"> • Fruits & Vegetables: participate in Stewardship Index for Specialty Crops; OR PRiME score has no high risk components for Integrated Pest Management Practices • Milk & Dairy: No antibiotics; and rBGH/rBST free • Meat & Poultry: Cage-free eggs; or Pasture raised; or USDA Grassfed; OR No antibiotics • Seafood: No seafood purchased listed as “Avoid” in the Monterey Bay Aquarium’s Seafood Watch Guide • Grains: Pesticide-free 				
Level 2 = 2 Points	<p>Overall: 15% annual average of total cost of food purchases, with a goal of increasing at least 2% per year will come from Level 2 environmentally sustainable sources. No seafood purchased should be listed as “Avoid” in the Monterey Bay Aquarium’s most recent Seafood Watch Guide. 25% annual average of total cost of food purchases by Year 5.</p> <ul style="list-style-type: none"> • Fruits & Vegetables: PRiME score indicates low-risk for Integrated Pest Management Practices; OR Protected Harvest certified; OR participate in Stewardship Index for Specialty Crops with targets for annual improvement; OR Non-GMO Project Verified; or Food Alliance Certified • Milk & Dairy: Non-GMO Project Verified; OR Animal Welfare Approved • Meat & Poultry: AGA Grassfed; OR Non-GMO Project Verified; OR Animal Welfare Approved • Seafood: Fish listed as “Good” and “Best” choices in Monterey Bay Aquarium’s Seafood Watch Guide • Grains: Food Alliance Certified; OR Non-GMO Project Verified 				
Level 3 = 3 Points	<p>Overall: 15% annual average of total cost of food purchases, with a goal of increasing at least 2% per year will come from Level 3 environmentally sustainable sources; No seafood purchased should be listed as “Avoid” in the Monterey Bay Aquarium’s most recent Seafood Watch Guide. 25% annual average of total cost of food purchases by Year 5.</p> <ul style="list-style-type: none"> • Fruits & Vegetables: USDA Organic; OR Biodynamic • Milk & Dairy: Food Alliance Certified; OR USDA Organic • Meat & Poultry: Food Alliance Certified; OR USDA Organic • Seafood: Marine Stewardship Council certified; OR 100% of fish listed as “Best Choice” in the Seafood Watch Guide • Grains: USDA Organic 				

RFP EXHIBIT J

Extra Points = 1 Point Each Points	Institution participates in "Meatless Mondays"				
	A minimum of 75% of all seafood is noted as "Best Choices" in the Monterey Bay Aquarium Guide OR certified by the Marine Stewardship Council.				
	50% annual average of total cost of food purchases comes from environmentally sustainable sources.				
Total Environmental Sustainability Points					

Value 3: Valued Workforce – Provide safe and healthy working conditions and fair compensation to all food chain workers and producers, from production to consumption

Objective	Benchmarks	Activities	Timeframe	Points
<p>Level 1 = 1 Point</p> <p>All vendors and suppliers sign in writing that they respect the freedom of association of farmers, ranchers, and fisherfolk and comply with domestic labor law (including state and local) in countries where they produce goods and services, as well as the core standards of the International Labour Organization (ILO):</p> <ol style="list-style-type: none"> 1. Freedom of association and the right to collective bargaining. 2. Elimination of all forms of forced or compulsory labor. 3. Abolition of child labor. 4. Elimination of discrimination with respect to employment or occupation 				
<p>Level 2 = 2 Points</p> <p>All suppliers sign in writing that they follow the law AND 5% annual average of total cost of food purchases comes from farms with social responsibility policies, which includes:</p> <ul style="list-style-type: none"> ▪ union or non-poverty wages ▪ respect for freedom of association and collective bargaining ▪ safe and healthy working conditions ▪ prohibition of child labor, except as allowed by domestic law and at least one additional employment benefit such as: ▪ health care benefits ▪ paid sick days ▪ profit-sharing with all employees; OR <p>Are Fair Trade Certified (for international products) 15% annual average of total cost of food purchases by Year 5.</p>				
<p>Level 3 = 3 Points</p> <p>All suppliers sign in writing that they follow the law AND 5% annual average of total cost of food purchases comes from combination of sources, including suppliers that:</p> <ul style="list-style-type: none"> ▪ Have a union contract with their employees; OR ▪ Are a worker-owned Cooperative; OR ▪ Have signed the CIW Fair Food Supplier Code of Conduct; OR ▪ Are Food Justice-Certified by the Agricultural Justice Project; OR ▪ Are certified by the Equitable Food Initiative <p>15% annual average of total cost of food purchases by Year 5.</p>				
<p>Extra Points = 1 Point Each</p> <p>Buying entity establishes a reporting system for workers to report violations with a protection for workers from retaliation.</p>				
<p>Institution complies with baseline Level 1 fair criteria AND 25% of annual average of total cost of food purchases comes from Level 2 or 3 fair sources.</p>				
Total Valued Workforce Points:				

Value 4: Animal Welfare – Provide healthy and humane care for livestock

	Objective	Benchmarks	Activities	Timeframe	Points
Level 1 = 1 Point	<p>Overall: 15% annual average of total cost of milk and dairy products and animal protein product purchases, increasing at least 2% per year will come from Level 1 humane sources; 100% of all eggs are cage-free. 25% annual average of total cost of food purchases by Year 5.</p> <ul style="list-style-type: none"> • Milk & Dairy: Produced from Pastured Cows OR USDA Organic • Meat & Poultry: Step 1 of Global Animal Partnership 5-Step Animal Welfare Rating standards; OR USDA Organic; OR Cage-free eggs; OR Pastured 				
Level 2 = 2 Points	<p>Overall: 15% annual average of total cost of milk and dairy products and animal protein products, increasing at least 2% per year will come from Level 2 humane sources; 100% of all eggs are cage-free. 25% annual average of total cost of food purchases by Year 5.</p> <ul style="list-style-type: none"> • Milk & Dairy: American Humane Certified • Meat & Poultry: Step 2 of Global Animal Partnership 5-Step Animal Welfare Rating standards; OR American Humane Certified 				
Level 3 = 3 Points	<p>Overall: 15% annual average of total cost of milk and dairy products, and animal protein product purchases, increasing at least 2% per year will come from Level 3 humane sources; 100% of all eggs are cage-free. 25% annual average of total cost of food purchases by Year 5.</p> <ul style="list-style-type: none"> • Milk & Dairy: Animal Welfare Approved; OR Humane Farm Animal Care/Certified Humane Raised and Handled® • Meat & Poultry: Step 3 or higher of Global Animal Partnership 5-Step Animal Welfare Rating standards; OR Animal Welfare Approved; OR Humane Farm Animal Care/Certified Humane Raised and Handled® 				
Extra Points = 1 Point Each	Institution encourages plant-based diets by offering 100% vegetarian and/or vegan options.				
	50% annual average of total cost of milk and dairy products, and animal protein products purchases come from humane sources.				
Total Animal Welfare Points:					

Value 5: Nutrition – *Promote health and well-being by offering generous portions of vegetables, fruits, and whole grains; reducing salt, added sugars, fats and oils; and by eliminating artificial additives.*

Objective	Benchmarks	Activities	Timeframe	Points
Fruits, vegetables, and whole grains account for at least 25% of total food purchases				
Seasonal fruits and vegetables are sourced to ensure best taste, quality, and price				
Purchase whole fruits, without added sugar. When whole and unprocessed fruit cannot be purchased, purchase frozen fruit. If frozen products are unavailable, fruit should be canned in its own juice with no sugars added				
Purchase whole vegetables, without added sodium and fat. When whole and unprocessed vegetables cannot be purchased, purchase frozen vegetables. If frozen products are unavailable, canned vegetables should be low sodium (per FDA definitions) or have “no salt added”				
Prioritize the purchase of whole-grain, high-fiber options				
Prioritize offering plant-based main dishes at each meal service				
If meat is offered, prioritize the purchase of “extra lean” (total fat ≤ 5%) and “lean” (total fat ≤ 10%) meat such as skinless chicken, turkey, ground beef, and pork				
If meat is offered, minimize the purchase of processed meats				
If dairy products are offered, prioritize the purchase of Fat-Free or Low Fat dairy products (1% milk fat or less with no added sweeteners). If milk is offered, soy, rice, or other non-dairy milk alternatives without added sweeteners are available				
Prioritize all juice purchased to be 100% fruit juice with no added sweeteners and vegetable juice that is Low Sodium as per FDA definitions				
At least 50% of available beverage choices (excluding 100% fruit and Low Sodium vegetable juices and Fat Free or Low Fat milk with no added sweeteners) must contain ≤ 25 calories per 8 oz				
Require drinking water (preferably cold tap water in at least 12 ounce cup sizes) to be offered				
Offer Low Fat and/or Low Calorie and/or Low Sodium condiments as per FDA definitions				
Commit to developing and implementing a gradual sodium reduction plan that meets current Dietary Guidelines for Americans (DGA) standards				
All pre-packaged food has zero grams trans fat per serving (as labeled)				
Prioritize the preparation of all protein, including fish, poultry, meat, or meat alternatives in a low fat way (broiling, grilling, baking, poaching, roasting, or steaming)				
Display water, diet drinks (do not exceed 25 cal. per 8oz), 100% fruit juice without added sweeteners, Low				

Sodium vegetable juices, Fat Free or Low Fat dairy products with no added sweeteners, and milk alternative products in eye level sections of beverage cases (if applicable)				
Eliminate the use of deep frying				
Highlight fruit with no-added sweeteners and non-fried vegetable offerings with signage				
Prioritize the location of fruit and/or non-fried vegetables at convenient, high-visibility locations (including at front of cafeteria lines) and within reach of checkout registers (if applicable)				
Develop a worksite wellness program including nutrition education for employees and/or patrons.				
Menu lists the nutritional information for each item using the federal menu labeling requirements under the Patient Protection and Affordable Care Act of 2010				
Prioritize portion control strategies, if applicable (e.g. utilizing 10' or smaller plates for all meals or make available reduced-size portions of at least 25% of menu items offered, and offer reduced-size portions at a lower price than regular-sized portions)				
Remove candy bars, cookies, chips and beverages with added sugars (such as soda, sports and energy drinks) from checkout register areas/point-of-purchase (if applicable)				
Eliminate the use of hydrogenated and partially hydrogenated oils for cooking and baking				
Level 1 (1 Point) – Meets 13 – 15 out of 25				
Level 2 (2 Points) – Meets 16 – 20 out of 25				
Level 3 (3 Points) – Meets 21 – 25 out of 25				

Total Nutrition Points:

GRAND TOTAL GFPP POINTS

Good Food Purchasing Commitment Levels		
Stars Awarded	Good Food Purchaser Status Level	Number of Points Needed
★	Good Food Purchaser – One Star	5 - 9
★★	Good Food Purchaser – Two Stars	10 - 14
★★★	Good Food Purchaser – Three Stars	15 - 19
★★★★	Good Food Purchaser – Four Stars	20 - 24
★★★★★	Good Food Purchaser – Five Stars	25+

CITY OF LOS ANGELES
DEPARTMENT OF RECREATION AND PARKS
REQUEST FOR PROPOSALS
FOR THE OPERATION AND MAINTENANCE OF THE GREEK THEATRE
FOOD AND BEVERAGE CONCESSION

RFP EXHIBIT K

Greek Theatre Venue Financial Data: 2010 - 2014

A. Over the term of the current Greek Theatre Concession Agreement, the guaranteed minimum annual revenue-sharing is \$1,200,000 annually.

B. The Gross Revenue at the Concession was reported as follows:

2010	2011	2012	2013	2014	Five-Year Average
\$16,487,608	\$20,228,755	\$20,948,810	\$22,806,300	\$27,270,618	\$21,548,418

C. The revenue-sharing payment to the City was reported as follows:

2010	2011	2012	2013	2014	Five-Year Average
\$1,200,000	\$1,458,709	\$1,521,669	\$1,654,209	\$1,977,314	\$1,562,380

D. Gross Revenue by Category:

Year	Gate	Parking	Sponsorship	Food & Beverage	Merchandise	Other
2010	\$9,987,114	\$953,234	\$281,992	\$2,076,510	\$454,940	\$2,733,818
2011	\$12,249,201	\$1,140,231	\$665,218	\$2,476,979	\$648,985	\$3,048,141
2012	\$13,236,981	\$1,144,182	\$475,465	\$2,383,180	\$723,036	\$2,985,966
2013	\$14,291,560	\$1,450,860	\$506,000	\$3,038,879	\$878,074	\$2,640,927
2014	\$17,053,844	\$1,782,534	\$547,150	\$3,775,076	\$1,018,471	\$3,093,543

E. Greek Theatre Venue Attendance and Pollstar Ranking Statistics: 2010 - 2014

Year	Live Music Events	Total Attendance	Pollstar Rank in the US
2010	46	190,055	21
2011	58	249,240	6
2012	56	234,868	11
2013	62	295,126	17
2014	77	308,427	22

CITY OF LOS ANGELES
DEPARTMENT OF RECREATION AND PARKS
REQUEST FOR PROPOSALS
FOR THE OPERATION AND MAINTENANCE OF
THE GREEK THEATRE CONCESSION

Community Research Overview

Community Research Overview

Survey Results

Neighborhood Concerns

Traffic and Safety are the Top Concerns

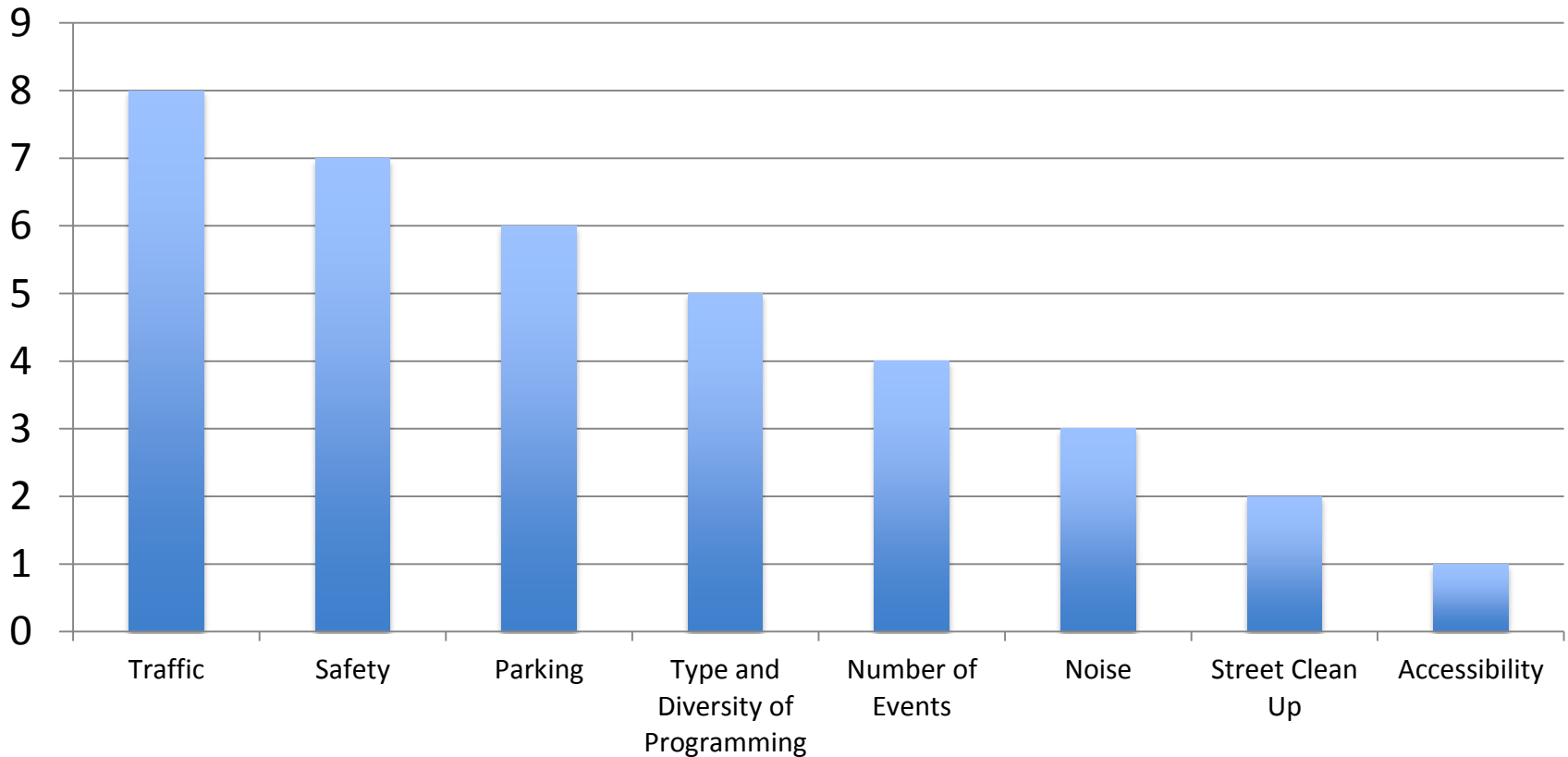

Community Research Overview

Survey Results

Fan Experience Section

- 74% of respondents rated the fan experience as **satisfactory or highly satisfactory**
- 65% rated ease and arrival of parking at **average or better**
- 80% rated the ushers and staff as **average or better**
- 85% rated the quality of sound and video as **average or better**
- 40% rated the concessions menu as **average or unsatisfactory**
- 30% rated the quality of food and service as **average or below**

Community Research Overview

Survey Results

Comparable Venue Experience

- 75% rated the actual concert experience as an intimate one
- 40% rated the fan experience as **equal to or less enjoyable** than comparable venues
 - Comparable venues mentioned:
 - Hollywood Bowl
 - Nokia
 - Staples Center
 - Gibson

Community Research Overview

Survey Results

Comments and Additional Feedback

- The respondents reported attending an average of three to four concerts at the Greek Theatre per season
- Respondents felt that parking should be less than \$20 because of the “hassle of stacked parking”
- Respondents regularly attended other events at the Hollywood Bowl, Nokia, Staples Center and others
- Main points throughout additional comments regarded:
 - Parking
 - Noise
 - Venue clean-up
 - Communication with neighborhood groups