

**BOARD REPORT**

**NO.** 26-090

**DATE** May 07, 2026

**C.D.** 11

**BOARD OF RECREATION AND PARK COMMISSIONERS**

**SUBJECT:** VENICE BEACH RECREATION CENTER ORIGINAL SKATE PARK – APPROVAL OF PROPOSED SKATEPARK IMPROVEMENTS AS AN IN-KIND DONATION FROM NICOLAI MARCIANO AND THE SKATEPARK PROJECT; CATEGORICAL EXEMPTION FROM THE PROVISIONS OF THE CALIFORNIA ENVIRONMENTAL QUALITY ACT (CEQA) PURSUANT TO ARTICLE 19, SECTIONS 15301(a) [INTERIOR OR EXTERIOR ALTERATIONS INVOLVING SUCH THINGS AS INTERIOR PARTITIONS, PLUMBING, AND ELECTRICAL CONVEYANCES, 15301(d) [RESTORATION OR REHABILITATION OF DETERIORATED OR DAMAGED STRUCTURES, FACILITIES, OR MECHANICAL EQUIPMENT TO MEET CURRENT STANDARDS OF PUBLIC HEALTH AND SAFETY], 15302 [REPLACEMENT OR RECONSTRUCTION OF EXISTING STRUCTURES AND FACILITIES WHERE THE NEW STRUCTURE WILL BE LOCATED ON THE SAME SITE AS THE STRUCTURE REPLACED AND HAVE SUBSTANTIALLY THE SAME PURPOSE AND CAPACITY] AND 15311(a) [ON PREMISE SIGNS] OF CALIFORNIA CEQA GUIDELINES AND ARTICLE III, SECTION 1, CLASS 1(1), CLASS 1(4), CLASS 2 AND CLASS 11(1) OF CITY CEQA GUIDELINES

* B. Aguirre	<u>BA</u>	M. Rudnick	_____
C. Stoneham	_____	C. Santo Domingo	_____
B. Jones	_____	N. Williams	_____

\_\_\_\_\_  
General Manager

Approved \_\_\_\_\_ Disapproved \_\_\_\_\_ Withdrawn \_\_\_\_\_

**RECOMMENDATIONS**

1. Approve the skatepark repairs and improvements (collectively, "Project") at the Venice Beach Little Skate Park proposed by The Skatepark Project (TSP), as further described in this Report and the approved plans attached hereto as Attachment 1;
2. Authorize the Department of Recreation and Parks (RAP) General Manager, or his designee, to send a letter from RAP to the California Coastal Commission declining to be a co-applicant to the coastal permit written exemption application;
3. Accept Nicolai Marciano and TSP's in-kind donation of the Project, valued at approximately \$180,000.00, to RAP, subject to the California Coastal Commission written

## BOARD REPORT

PG. 2 NO. 26-090

- exemption, completion of the Project and a post-development inspection by RAP's Planning, Maintenance, and Construction Branch (PMC);
4. Approve the proposed donor recognition signage attached hereto as Attachment 2, consisting of a 12"x24" non-precious metal plaque (Plaque) expressing RAP's appreciation to Nicolai Marciano and TSP for its in-kind donation of the Project;
  5. Authorize PMC to issue a Temporary, Revocable Right-of-Entry permit to TSP and its contractors (Contractor), allowing access to Venice Beach Little Skatepark for the construction, installation, and completion of said Project and installation of the Plaque, subject to necessary permits being obtained by Contractor;
  6. Determine that the Project is categorically exempt from the provisions of the California Environmental Quality Act (CEQA) pursuant to Article 19, Sections 15301(a) [Interior or exterior alterations involving such things as interior partitions, plumbing, and electrical conveyances, 15301(d) [Restoration or rehabilitation of deteriorated or damaged structures, facilities, or mechanical equipment to meet current standards of public health and safety], 15302 [Replacement or reconstruction of existing structures and facilities where the new structure will be located on the same site as the structure replaced and have substantially the same purpose and capacity] and 15311(a) [On Premise signs] of California CEQA Guidelines and Article III, Section 1, Class 1(1), class 1(4), Class 2 and Class 11(1) of City CEQA Guidelines, and direct staff to file a Notice of Exemption (NOE) with the Los Angeles County Clerk and the Governor's Office of Land Use and Climate Innovation;
  7. Authorize RAP's Chief Accounting Employee to prepare a check to the Los Angeles County Clerk in the amount of \$25.00 for the purpose of filing the NOE; and
  8. Authorize RAP staff to make technical corrections in order to carry out the intent of the Board in approving this Report.

### SUMMARY

The Skatepark Project (TSP) approached the Department of Recreation and Parks with an offer to renovate the small skatepark commonly known as the Original Venice Beach Skatepark (Original Skatepark). The existing features within the space will be renovated to contemporary skate space standards of accessibility, durability, and appeal, in an effort to further support and honor Venice's long-standing impact on skateboarding and action sports culture. Additionally, the Project will improve access for all abilities and types of action sports participants while increasing general participation from all levels.

The Original Skatepark is centrally located on the Venice Beach Boardwalk on East Market Street between Oceanfront Walk and the Venice Beach bike path adjacent to the 16,000 square-foot Venice Beach Skatepark that opened in 2009.

## BOARD REPORT

PG. 3 NO. 26-090

The Project is being co-funded by Nicolai Marciano and TSP (collectively, “Donors”). Through the proposed Project, Los Angeles native Nicolai Marciano, whose family founded the Guess clothing company, continues a long-standing tradition of community philanthropy and giving back to the City. TSP, originally founded as The Tony Hawk Foundation, is a non-profit organization founded by professional skateboarder Tony Hawk that is dedicated to helping underserved communities build free, safe, and high quality public skateparks. Since its inception nearly twenty-five years ago, TSP has built nearly 700 skateparks across all 50 states, and has helped to fund nearly twenty percent of skateparks in the United States. Additionally, TSP has provided thousands of participants with skateboards, helmets, and pads, and hosted contests and clinics to bring attention to skateboarding while challenging participants to improve their skateboarding skills. The Project is also supported by Lee Spielman, a California native who has spent years shaping community spaces and cultural platforms, using music and street culture to create access, connection, and meaningful experiences. Additionally, the Project received design support from original Venice professional skating legend and skatepark advocate Jesse Martinez, professional skater Ishod Wair, skateboarder and designer Jim Callans, Dan Levy, skatepark designer and West Los Angeles native Alec Beck, and surfer and skateboarder Richard Massie.

Staff recommends approval of this Report to authorize the installation of the Project for the benefit and enjoyment of Venice Beach visitors, the skateboard community, and City residents.

### TREES AND SHADE

No trees will be removed or added as part of the Project.

### ENVIRONMENTAL IMPACT

Based on the scope of work, the Project consists of minor exterior alterations of existing public structures, restoration or rehabilitation of deteriorated or damaged structures, and replacement of existing structures and installation of new signs.

According to the parcel profile report retrieved from NavigateLA ([www.navigatela.lacity.org](http://www.navigatela.lacity.org)) on April 17, 2026, this site is located within a coastal, methane, and liquefaction zone. However, the Project is contingent on the approval of the Coastal Commission and its scope is limited to ensure the Project will not increase patrons to additional methane seepage exposure or increase the risk of liquefaction. Therefore, there is no reasonable possibility that the proposed Project may impact on an environmental resource of hazardous or critical concern or have a significant effect due to unusual circumstances. No other known projects would involve cumulatively significant impacts, and no future projects would result from the proposed Project. As of April 17, 2026, the State Department of Toxic Substances Control (DTSC) (Envirostor at [www.envirostor.dtsc.ca.gov](http://www.envirostor.dtsc.ca.gov)) and the State Water Resources Control Board (SWRCB) (Geotracker at <https://geotracker.waterboards.ca.gov/>) listed the Project site as SL163752343, Damson Oil Field. The site was used as an oil field between approximately 1966 and 1989; incidental to this use was on-site storage of crude oil, drilling mud, wastewater, motor fuels, and chemicals used for facility cleaning, maintenance, treatment of wastewater, and other uses, with the site’s oil production wells reportedly abandoned in 1991. After abandonment, the oil related infrastructure was removed and contaminated soil was excavated and hauled away. Monitoring wells were

## BOARD REPORT

PG. 4 NO. 26-090

installed and in 2006, the Regional Water Quality Control Board closed the case after concluding that no further remediation was necessary to allow the reuse of the site. According to the Caltrans Scenic Highway Map, there is no scenic highway located within or adjacent to the Project site. Furthermore, the proposed Project is not within an historic site and will not have any significant effect on historic resources.

Based on this information, RAP staff recommends that the Board of Recreation and Park Commissioners (Board) determines that the proposed Project is categorically exempt from the provisions of the California Environmental Quality Act (CEQA) pursuant to Article 19, Sections 15301(a), 15301(d), 15302 and 15311(a) of California CEQA Guidelines and Article III Section 1, Class 1(1), Class 1(4), Class 2 and Class 11(1) of City CEQA Guidelines. Staff will file a Notice of Exemption with the Los Angeles County Clerk and the Governor's Office of Land Use and Climate Innovation upon Board's approval.

### FISCAL IMPACT

This Board action will have no adverse impact on the RAP General Fund, as Nicolai Marciano and TSP will be funding the Project in its entirety.

This Report was prepared by Melissa Bettis, Management Analyst, Partnership Section.

### LIST OF ATTACHMENTS/EXHIBITS

- 1) Proposed project plan
- 2) Proposed donor recognition signage

















**THE SKATEPARK PROJECT™**

1611 S. Melrose Drive  
Suite A #360  
Vista, CA 92081

**CITY OF LOS ANGELES**

WINDWARD PLAZA  
1500 OCEAN  
FRONT WALK,  
LOS ANGELES, CA  
90291

**VENICE BEACH SKATE PLAZA**

**PROPOSED UPDATES**

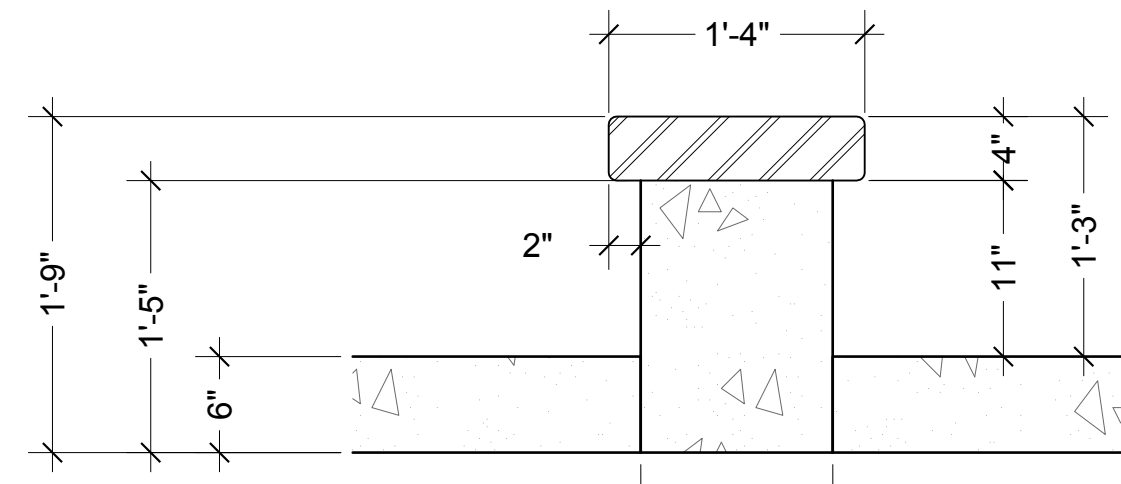

**SECTION A**

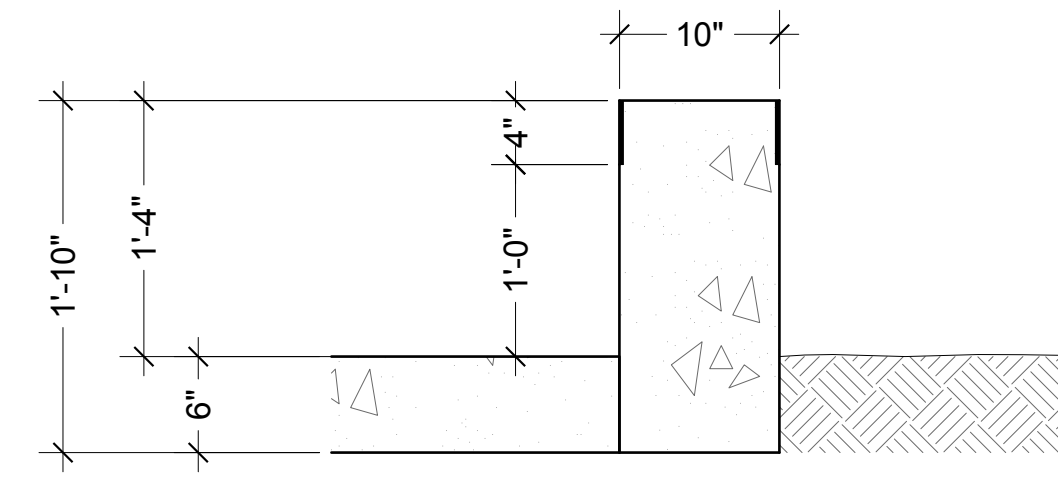

**SECTION B**

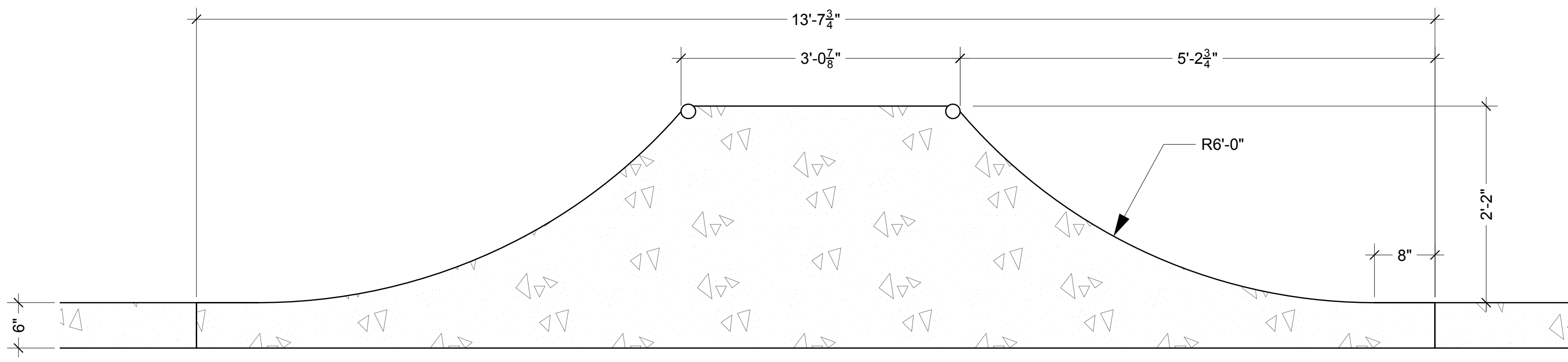

**SECTION D1**

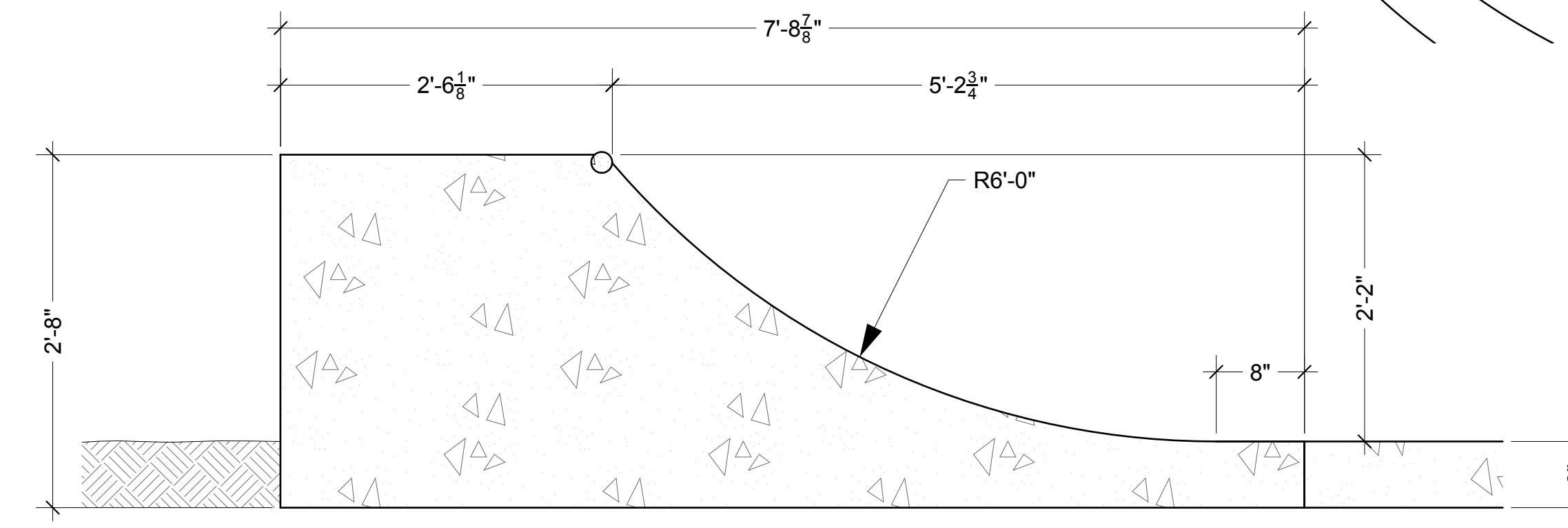

**SECTION D2**

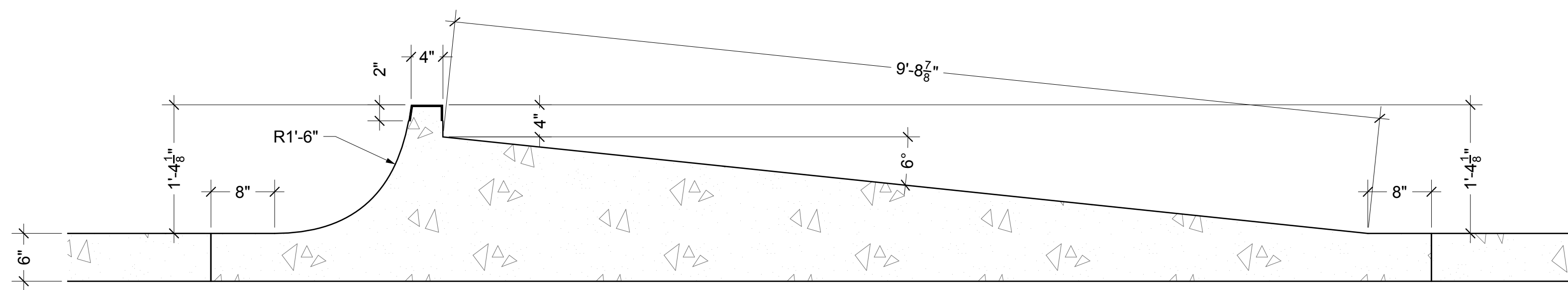

**SECTION E**

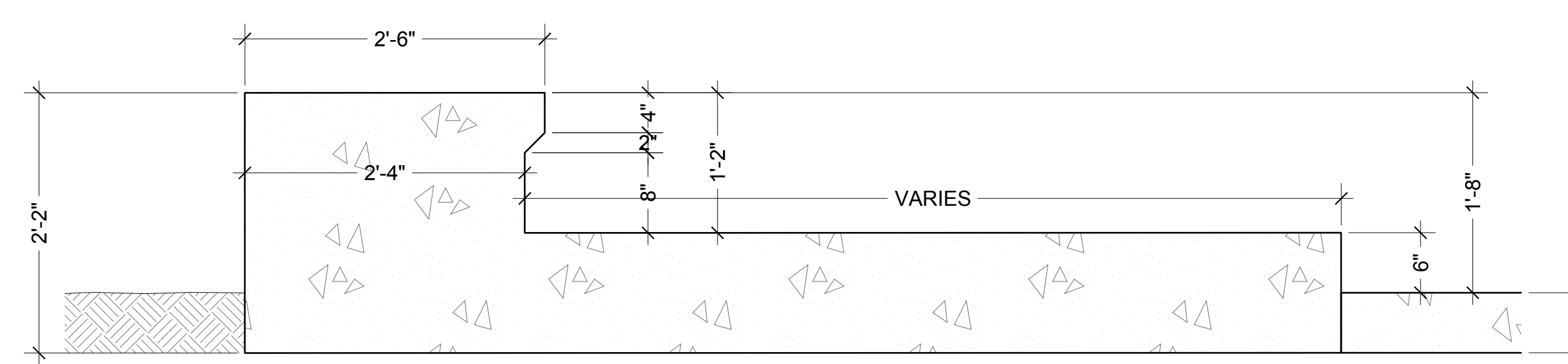

**SECTION F**

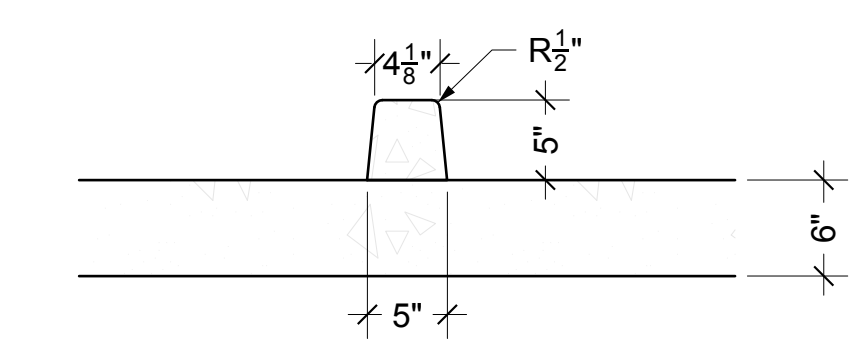

**SECTION G**

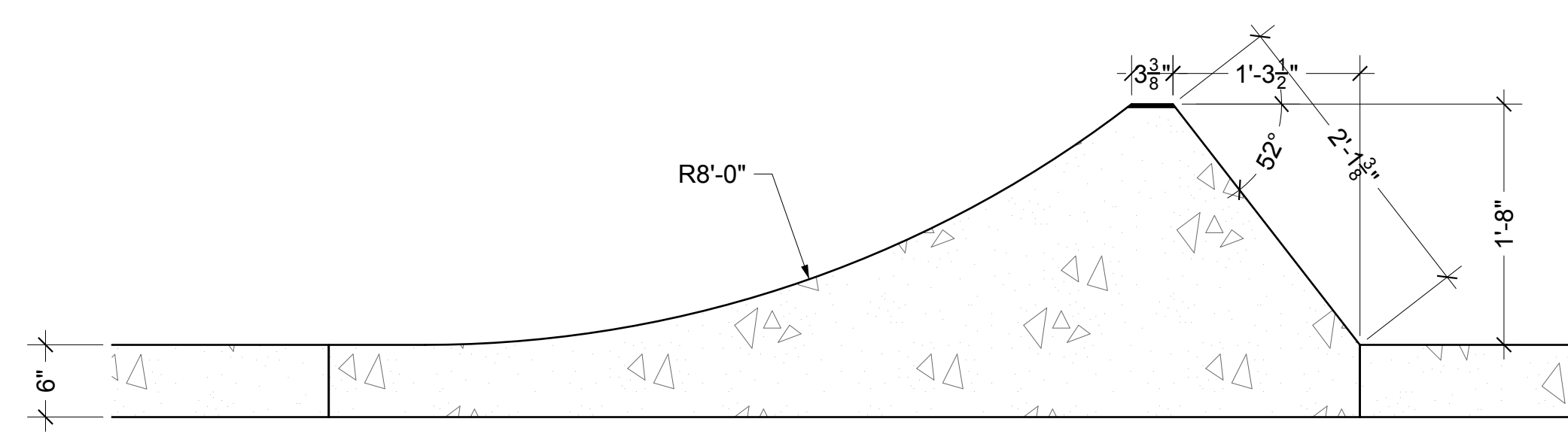

**SECTION H**

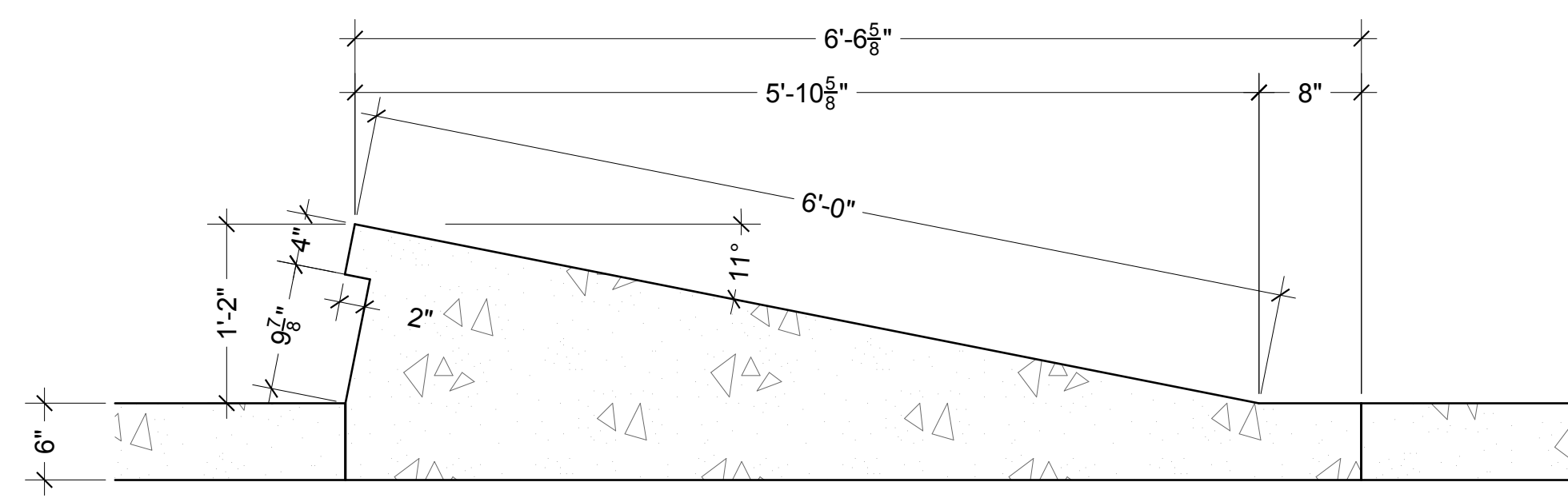

**SECTION I**

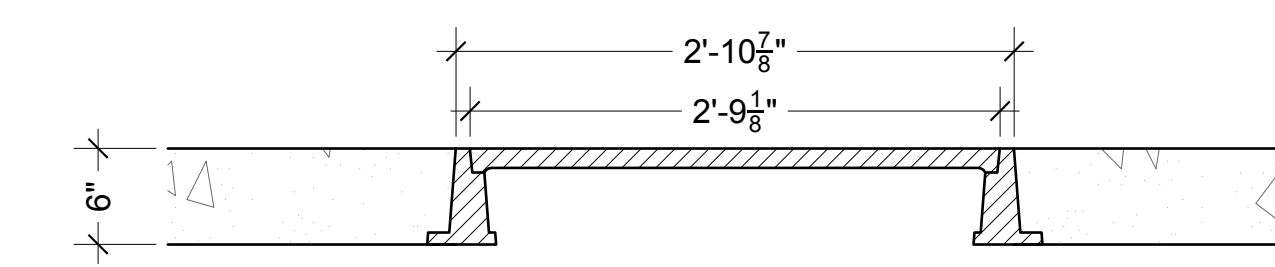

**SECTION J**

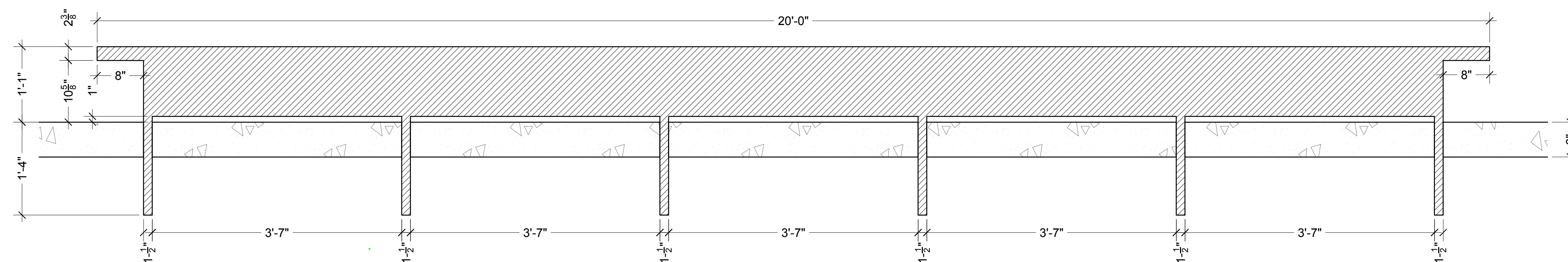

**SECTION K1**

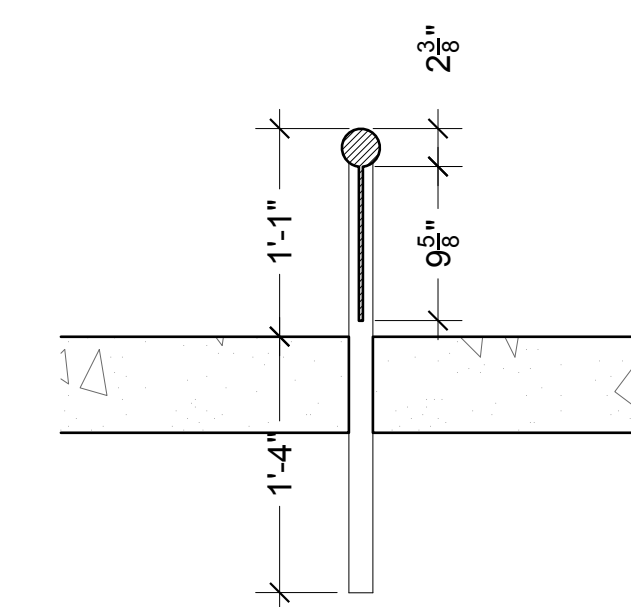

**SECTION K2**

SCALE: 1" = 1'-0"

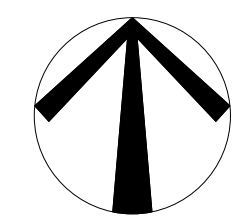
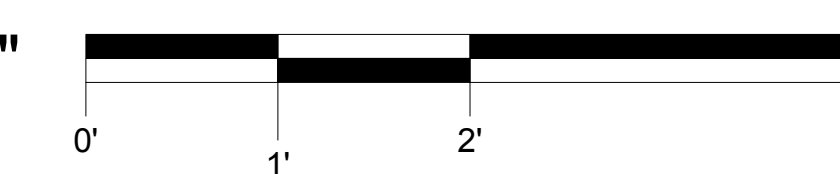

**Issue dates**

Date	Description
08/05/25	CONCEPT DESIGN

Sheet title:

**SK4.0 SECTIONS**

Drawings by: Jim Callans oldstar@mac.com  
Project Mgmt: Alec Beck alec@skatepark.org  
Project number:

# ORIGINAL VENICE BEACH SKATEPARK

*Los Angeles, California*

---

The City of Los Angeles Department of Recreation and Parks  
Acknowledges the generous support of

**NICOLAI MARCIANO & THE SKATEPARK PROJECT**

For the refurbishment of this skatepark



With special thanks to:  
Jesse Martinez, Ishod Wair,  
Richard Massie, & Lee Spielman

